

AUGUST 26, 2022

THE AUSTIN

VOL. 41 • NO. 52

FREE
BUT NOT CHEAP

CHRONICLE



BEHIND THE WHEEL

After five years of fine-tuning, the perfectionist producer and rapper rolls out *Fifth Wheel Fairytale*

BY JULIAN TOWERS

WITH DEEZIE BROWN

SEE PAGE 50

ALSO LOCAL ELECTIONS PREVIEW P.18 QUEER FILM ARCHIVIST ELIZABETH PURCHELL, IN THE FLESH P.26 RESTAURANT REVIEW: HILDEE'S TEXAS DINE-INN P.44

PUBLISHER Nick Barbaro
ASSOCIATE PUBLISHER Cassidy Frazier

EDITORIAL

EDITOR Kimberley Jones
MANAGING EDITOR James Renovitch
NEWS Mike Clark-Madison
ASSISTANT NEWS Maggie Q. Thompson
CULTURE Richard Whittaker
MUSIC Kevin Curtin
FOOD Melanie Haupt

EVENT LISTINGS

SPECIAL SCREENINGS & COMMUNITY LISTINGS
Kat McNevis
ARTS LISTINGS & FOOD EVENTS
Wayne Alan Brenner
CLUB LISTINGS Derek Udensi
COMMUNITY LISTINGS James Scott

STAFF WRITERS

Rachel Rascoe, Austin Sanders

CONTRIBUTING WRITERS

FILM Marjorie Baumgarten
DAY TRIPS Gerald E. McLeod
THE VERDE REPORT Eric Goodman
BEER Eric Puga
MR. SMARTY PANTS R.U. Steinberg

PRODUCTION

PRODUCTION / ART DIRECTOR Zoke Barbaro
ASSOCIATE ART DIRECTOR Lauren Johnson
WEB / DIGITAL DIRECTOR Michael Bartnett
WEB CONSULTANT Brian Barry
GRAPHIC DESIGNER Jeff Gammill

STAFF PHOTOGRAPHERS John Anderson, Jana Birchum
PROOFREADERS Lina Fisher, Jasmine Lane, James Scott

ADVERTISING & MARKETING

ADVERTISING DIRECTOR Cassidy Frazier
OPERATIONS MANAGER Trace Thurman
MARKETING & ENGAGEMENT MANAGER Nick Corey
EVENT COORDINATOR Cassie Arredondo
PUBLIC RELATIONS Sarah K. Wolf
SENIOR ACCOUNT EXECUTIVES
Jerald Corder, Carolyn Phillips
ACCOUNT EXECUTIVES David Kleppe, Courtney Smith-Bush, Chelsea Taylor, Gloria Williamson
CLASSIFIEDS / LEGAL NOTICES Bobby Leath
LUV DOC / CIRCULATION / SPECIAL EVENTS Dan Hardick
NATIONAL ADVERTISING Voice Media Group (888/278-9866, vmgadvertising.com)

OFFICE STAFF

CONTROLLER Liz Franklin
OFFICE MANAGER / SUBSCRIPTIONS Carrie Young
CREDIT MANAGER cindy soo
INFO DESK Zach Pearce
SYSTEMS ADMINISTRATOR Brandon Watkins
CHIEF MORALE OFFICER Hank

CIRCULATION

Perry Drake, Tom Fairchild, Ruben Flores, Andrew Gerfers, Eric McKinney, Grant Melcher, Matt Meshbane, Paul Minor, Peter Oberheide, Rich Russell, Jonina Sims, Zeb Sommers, Bryan Zirkelbach

CONTRIBUTORS

Bob Abelman, Abe Asher, Brant Bingamon, Rob Brezny, Steve Davis, Christina Garcia, Ryan Hennessee, Raoul Hernandez, Sam Hurt, Sarah Jane, Matthew Monagle, Jenny Nulf, Robert Penson, Alejandra Ramirez, Jen Sorensen, Michael Toland, Tom Tomorrow, Julian Towers

The Austin Chronicle (ISSN: 1074-0740) is published by The Austin Chronicle Corporation weekly 52 times per year at 4000 N. I-35, Austin, TX 78751. 512/454-5766 ©2013 Austin Chronicle Corp. All rights reserved.

Subscriptions: One year: \$150 2nd class. Six months: \$75 2nd class. Periodicals Postage Paid at Austin, TX.

POSTMASTER: Send address changes to The Austin Chronicle, 4000 N. I-35, Austin, TX 78751.

Unsolicited submissions (including but not limited to articles, artwork, photographs, and résumés) are not returned.

50 Cover Story

BEHIND THE WHEEL WITH DEEZIE BROWN

After five years of fine-tuning, the perfectionist producer and rapper rolls out 5th *Wheel Fairytale*
BY JULIAN TOWERS



COVER PHOTO BY JOHN ANDERSON

4 Feedback

6 OPINION Project Connect: We Deserve It
BY BILL MCCAMLEY

8 News

8 AUSTIN AT LARGE
BY MIKE CLARK-MADISON

10 PUBLIC NOTICE
BY NICK BARBARO

12 City ups base wage for workers; renters face crippling costs; Kaitlin Armstrong defense team calls police narrative "misogynistic and fictitious"; R.I.P. Lewis Conway Jr.; more

18 LOCAL ELECTIONS

PREVIEW Who's on the ballot for mayoral and City Council races
BY THE NEWS STAFF

24 Calendar

26 Culture

26 ELIZABETH PURCHELL, IN THE FLESH The film historian and archivist is leading the reappraisal of porn and erotica as a vital chapter in the history of queer liberation
BY JAMES SCOTT

27 ARTS EVENTS

28 FIVE THINGS
BY WAYNE ALAN BRENNER

30 ARTS REVIEW *The Inheritance, Part 1*
BY BOB ABELMAN

32 COMMUNITY EVENTS

33 QMMUNITY BY JAMES SCOTT

35 THE VERDE REPORT
BY ERIC GOODMAN

36 DAY TRIPS
BY GERALD E. MCLEOD

38 MOVIE REVIEWS *Beast, Breaking, Funny Pages, The Innocents, Maneater, Spin Me Round, Three Thousand Years of Longing*

42 SPECIAL SCREENINGS
BY KAT MCNEVINS

44 Food

44 RESTAURANT REVIEW: HILDEE'S TEXAS DINE-INN Ryan Hildebrand's Hill Country bistro has its ups and downs
BY MELANIE HAUPT

46 FOOD NEWS BUFFET
BY WAYNE ALAN BRENNER

48 Music

48 FASTER THAN SOUND
BY RACHEL RASCOE

54 WHAT WE'RE LISTENING TO + CRUCIAL CONCERTS

56 CLUBS LISTINGS

58 MUSIC NOTES
BY DEREK UDENSI

60 Back

THE LUV DOC COMIX
MR. SMARTY PANTS

61 Classifieds

70 CROSSWORD
FREE WILL ASTROLOGY

Founded in 1981 and committed to a progressive point of view, *The Austin Chronicle* is an independent, locally owned and operated alternative newsweekly.

ONLINE THIS WEEK

EVERY DAY IS NATIONAL DOG DAY IN OUR HOUSE
The *Chronicle* celebrates National Dog Day on Aug. 26 with a photo gallery of staffers and our favorite pups.

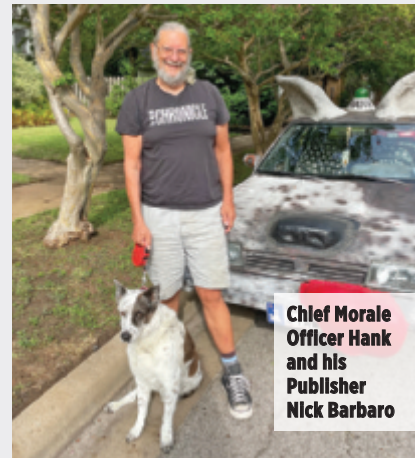

Chief Morale Officer Hank and his Publisher Nick Barbaro

SUSAN MOFFAT

LA BARBECUE INVESTIGATION LeAnn Mueller, owner of la Barbecue, and her wife, Allison Clem, who also manages the barbecue trailer, have been indicted in a case of workers' compensation fraud. The investigation relates to a 2016 employee injury on the job, according to the Texas Department of Insurance.

MERGING TRAUMA AND TERROR Culture Editor Richard Whittaker interviews the director and crew of psychological horror *When I Consume You*.

REACHING QUEERTOPIA ... Local LGBTQ+ homelessness community group aims to build a bigger, better home for Austin queers without shelter.

GET 'EM WHILE THEY'RE HOT The Austin Food & Wine Festival announced the lineup for its Nov. 4-6 festival, including a new Wurst Weekend Kickoff with Tim Love (Lonesome Dove) and Jesse Herman (Koko's Bavarian). Single-day tickets are already sold out, but the pretty pricey Weekender (\$250) and All-In (\$625) two-day tickets are still available.

KING OF AMERICA IN AUSTIN Elvis Costello will play a show with T Bone Burnett and Charlie Sexton at the ACL Live at the Moody in December to benefit the Musician Treatment Foundation, a nonprofit that provides surgery and medical care for musicians experiencing issues with their hands, shoulders, and elbows.

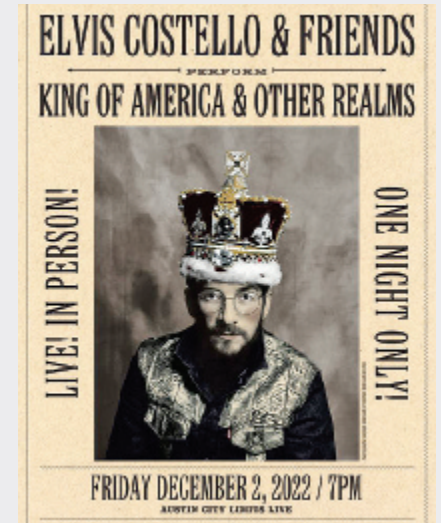

PUNK IN PICTURES Photographer David Brendan Hall captured the sights of Big Bill's Bill Ball 5 at Swan Dive, featuring Big Bill, Pussy Gillette, Sailor Poon, Calliope Musicals, and more.

Everywhere you want to be in Austin: **AUSTINCHRONICLE.COM/EVENTS**

THE AUSTIN CHRONICLE'S ONLINE STORE

THE AUSTIN CHRONICLE

NEW STUFF! CHECK IT OUT.

AUSTINCHRONICLE.COM/STORE

DE DISCOUNT ELECTRONICS

9711 Menchaca • 512-458-8612
 1001 S. IH35 Round Rock • 512-637-7051
 4005 Parmer Lane • 512-983-9989

VOTED "ONE OF AMERICA'S
 FASTEST GROWING PRIVATE
 COMPANIES" 7 YEARS IN
 A ROW - INC. MAGAZINE



VOTED "BEST COMPUTER
 STORE" YEAR AFTER YEAR
 - AUSTIN CHRONICLE



70% OFF LAPTOPS + PCS EVERY DAY!



Quad Core Dell Optiplex
 9020 Ultra Small
\$145



Dell Ultrasharp U2311h
 23" Full HD Monitor
\$85



Toshiba Portege
 Z30 i7 Laptop
 DE DISCOUNT ELECTRONICS
\$275



Sell Us Your Stuff
CASH ON THE SPOT!

Same price online or in stores. In store pick up or next day (UPS Ground) delivery available.
 You won't find these deals on Amazon or Ebay. Discount Electronics only sells direct.

4.7 ★★★★★ 94% Positive (955 reviews) discountelectronics.com/chronicle



DE DISCOUNT ELECTRONICS RECYCLING

When it's time for your company to upgrade, Discount Electronics makes it easy to recycle your old computer equipment. Unlike other recyclers, we pay you on the spot, and make it a quick and painless transaction. We can help with all types of office equipment and even office furniture. If you have 10 to 1,000 pieces you need to dispose of, call Neo at 512-812-8080. discountelectronics.com/recycling





WAREHOUSE SALE

40+ years of covering Austin means we have a lot of archives. Help us make room for another 40 by buying that back issue or ten you've always wanted.

1 copy for \$5, 10 copies for \$10, and up to 50 copies for \$20.

Call 512-454-5766 for more information
austinchronicle.com/subscriptions



Got Something to Get Off Your Chest?

Informed opinions. Personal essays. Humor pieces. Hot takes. *The Austin Chronicle's* Opinion section is the place for readers to share what's on their mind.

Submit your op-ed here:
austinchronicle.com/contact/opinion



Feedback

LETTERS + COMMENTS

NEW BOND BLUES

Dear Editor,

I read your article on the proposed AISD bond with great interest as an AISD parent and a long-time supporter of every bond that comes across the ballot. This year my interest in bonds has cooled. I have voted for billions in bonds knowing that each one would impact my budget; but what have I accomplished beyond pricing myself out of my own city? You know the drill: AISD is facing \$800 million in recapture payments to the hinterlands (an estimated \$6 billion total since 2001, according to the district), AISD enrollment is stalled despite Central Texas' overall growth, and schools are forever on the chopping block; how is yet another property tax hike going to address what's fundamentally dysfunctional? I'm especially salty since my kids' school was shuttered in the 2020 clo-

LETTERS TO THE EDITOR must be signed with full name and include daytime phone number, full address, or email address. Letters should be no longer than 300 words. We reserve the right to edit all submissions. Letters may not be edited, added to, or changed by sender once we receive them.

General email address: mail@austinchronicle.com
Letters online: austinchronicle.com/feedback

Mailing address: *The Austin Chronicle*,
PO Box 4189, Austin, TX 78765

ures – where was the last billion-dollar bond then? I have more faith in the current AISD board than I have in a long time, and when people like LaTisha Anderson says she has “never seen AISD bring forward such an equity-focused bond” I am inclined to listen. But rather than looking ahead, I think AISD – and Austin as a whole – needs to better account for the money we've already allocated for projects around the city. I don't need another grand vision, I want accountability. I'll show you the money if you show me the progress.

Ian Ragsdale

THIS MODERN WORLD

by TOM TOMORROW

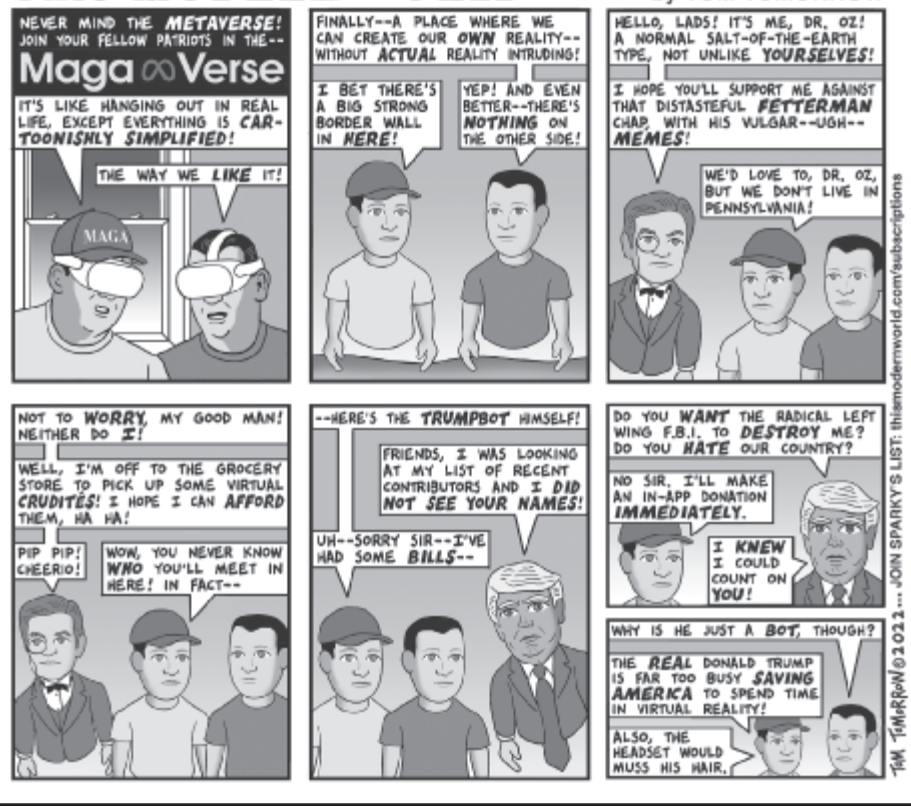

INDEPENDENT AND FREE



**iHeart
RADIO**



SPIKED SELTZER

**VOTE
TEXAS
.GOV**

POWERED BY THE
TEXAS SECRETARY OF STATE

AUGUST 27, 2022



Don't
mess with
Texas[®]



**16TH
ANNUAL**

BAT FEST

CONGRESS AVENUE BRIDGE



ONE AND A HALF MILLION MEXICAN FREE-TAILED BATS, TWO STAGES OF LIVE MUSIC

TOADIES, CHAMILLIONAIRE, KOLBY COOPER, THE UNLIKELY CANDIDATES,
THE NIXONS, BUN B, SLIM THUG, BLACKILLAC, LOGAN JAHNKE, LIL KEKE, LANE SMITH

PLUS - ARTS, CRAFTS, FOOD & DRINKS
TICKETS: \$25 ADVANCE AND AT THE GATE INCLUDING ALL FEES, KIDS UNDER 8 FREE
SPECIAL VIP TICKETS AVAILABLE
WWW.BATFEST.COM

KUT 90.5

ATXPLAINED LIVE

September 28
Paramount Theatre

You asked. We answered!

Live storytelling – all about Austin – from your favorite KUT reporters

Tickets on sale now at AustinTheatre.org

Sponsored by the Austin-Bergstrom International Airport's concessions program, Thundercloud Subs & the Extended Campus at The University of Texas at Austin

- Trash Disposal Without the Landfill -

 **Duke's** Junk We Take
JUNK RECYCLING

Mattresses Furniture Appliances Recycling Household Trash

Pick-Up Service

Drop-Off Centers

www.dukesjunkrecycling.com or call (512) 520-7495

Full list of accepted items & pricing on website

OPEN
7 DAYS A WEEK



Visit our Recycling & Disposal Drop-Off Center in North Austin
1602 Bench Mark Drive (right off of IH-35 & Howard Ln)

OPINION VOICES FROM THE COMMUNITY

PROJECT CONNECT: WE DESERVE IT

You're sitting in traffic, on 35 or MoPac. Maybe you're commuting to work, or heading to the airport. It's slow. It's hot. Or maybe it's pouring rain with the roads slow and dangerously slick. You crawl past a gas station and can't believe the price. The days of gridlock have returned, and you wish that there was a better way.

Luckily Austin voters overwhelmingly passed Project Connect in 2020, so this way is coming with new buses and trains delivering better options for all of us. How?

Project Connect will bring rapid transit bus services to major transport corridors in the area, connecting Downtown with Colony Park and South Austin, and all of Pleasant Valley. The service will be implemented by next year.

Orange/Blue line trains will give higher speed, consistent access to dense areas along the Drag and Riverside, while providing more options to large venues like the Downtown convention center and an Austin airport that continues to set passenger records.

These will link with the Red Line and the new McKalla Station located at Q2 Stadium, which expects to see 20,000 fans every for Austin FC game.

Every bus of commuters can take up to 50 cars off the road, every train up to 150. So Project Connect benefits people who ride it and those still driving.

The benefits don't end with more options and less traffic:

· Project Connect's increased transit services will let people get around cheaper. Individuals who take public transportation rather than drive can save \$10,000 per year, and this number will only grow as gas prices increase.

· More public transit use can cut traffic deaths in half. This is hugely important as national traffic deaths are at the highest levels in 16 years.

· We've had one of the hottest summers on record, and are living with the consequences of climate change. Light rail commuters average 5 times less carbon emissions than an SUV driver.

· Workers will have easier, cheaper, and less stressful ways to get to commute, and employers will have more incentive to participate in Cap Metro's MetroWorks bulk purchasing plan for their employees.

· Project Connect will create jobs, which include construction, new operators needed for the system, and in the greater economy as businesses (especially in the tech industry) want to start and grow in places with robust public transit systems.

· These new lines will give greater event access, reducing traffic jams around Darrell K. Royal-Texas Memorial Stadium on fall Saturdays and Q2. It will also be a benefit to Downtown music venues as everyone in the community will be able to see concerts easier without parking worries.

· Mixed-use transit-oriented development will provide more affordable housing for our residents while allowing them to live close to train and bus stations, which can cut bills even further.

· New bus and train lines will combine with the city's corridor improvement efforts to provide more last mile options for pedestrians, cyclists, scooter users, and our differently abled friends and neighbors.

We know Project Connect isn't perfect. People will still need cars, and there will still be traffic jams and accidents after it's built. And we understand some hard decisions need to be made as designs and cost estimates are finalized, with not everybody being happy with every decision.

But we cannot go backwards. Austin is a growing, modern city and Project Connect is a critical piece of the puzzle in making it easier for us all to get to jobs, hospitals, schools, and parks. We deserve a robust, modern transit system, including train and bus systems working together, that will bring us closer.

Let's all stay engaged, educated, and supportive as we move this project forward. ■

Bill McCamley is the executive director of Transit Forward, a local nonprofit whose mission is to educate and engage Austinites about public transit.

BY BILL
MCCAMLEY

Got something to get off your chest?

The *Chronicle* welcomes submissions of opinion pieces on any topic from the community. Find guidelines and tips at austinchronicle.com/contact/opinion.



LA LUCHA ESTIVAL

ATXFC

2022

AGOSTO
SATURDAY
27

AUSTIN
TEXAS

LUSTRE,
PEARL
RAINEY ST.

DOORS
7 PM

PRESENTANDO

EL ÚNICO...

VERDISIMO

SPECIAL GUESTS
PELIGROSA
7PM
THE TIARRAS
8PM
LUCHA
9PM

FEATURING
EL RAYO
KING CORTEZ
EL ANGELITO
BRYSON SCOTT
AGES 21+

VERDISIMOATX.COM

“The outrage over helping working people with student loans I think is just simply wrong – dead wrong.”

– President Joe Biden from the White House Aug. 24, after announcing student debt cancellation of \$10,000 for most borrowers



COURTESY OF GAGE SKIDMORE

HEADLINES

(APA) NOT THE SAME AS IT WAS Austin Police Association President Ken Casaday retired Wednesday, Aug. 24, from both the department and the union, which he's led since 2014 and served since 2001. Casaday told CBS Austin that his decision wasn't related to ongoing negotiations on a new police contract, but that he wants more time with his family.

ABOUT DAMN TIME For nine families of victims killed during the May 24 mass shooting in Uvalde, California-based law firm Bonner & Bonner is seeking \$27 billion from governmental entities, including the school district. The class-action lawsuit points to the month-old Texas House committee report on the shooting, which found “systemic failures and egregious poor decision making.” The money, if awarded to the class, would compensate families and establish a medical monitoring fund to pay for counseling.

BREAK MY RIGHT TO LEAVE THE STATE With Texas' “trigger law” going into effect Thursday, a group of Texas abortion funds including Lilith Fund and Fund Texas Choice filed suit in federal district court against Attorney General Ken Paxton and local prosecutors Tuesday, Aug. 23, to block threats of criminal prosecution. As Lilith Fund put it in a news release, rights to free speech, interstate travel, and political donations are all on the line.

WAIT FOR U (TO MAKE A RULING) Round Rock had a win this week in its legal battle to maintain a 30-year-old deal with Dell Technologies, which earns the city millions in sales tax from online purchases of Dell products. A Travis County district judge sided with Round Rock, ruling that Texas Comptroller Glenn Hegar's office didn't follow procedure when it tried to put a new policy in place that would have altered online sales tax collection for Round Rock and several other Texas cities that have similar deals with online sellers based there.

I NEED YOU TO STAY (FREE) Barton Springs Pool's beloved night swims – traditionally free to the public from 9 to 10pm daily – are actually dependent on the moon phase, as one Chronicle staff member discovered the hard way. On full moon nights the city charges an entry fee, the city Parks and Recreation Dept. confirmed. This began in 2016 after a full moon party brought drugs, alcohol, and over 2,500 swimmers.

SUPER FREAKY LAKE Speaking of swimming, after more than 50 days without a drop, heavy rainfall Monday flooded creeks and carried thousands of pounds of trash into Lady Bird Lake. Though the city's Watershed Protection Department's crews regularly clean creeks, with some creeks dried trash built up, KXAN reported. The city says people should stay out of Lady Bird Lake for at least three days after heavy rains to reduce exposure to pollutants.



JANA BIRCHUM

During the Austin Justice Coalition's quarterly General Assembly meeting on August 20, 2022, DOPE (District Organizing: Project Engage) District 1 leads Alkelsha Black (I) and Reese Herd II speak. The assembly is meant to cover AJC's organizing strategy and form organizing visions in each district.

Suffering With the Statesman

Ragging on the daily isn't as much fun now, but sometimes it still needs to happen

Twenty-odd years ago, when I was on this desk the first time and Kirk Watson was mayor (for the first time?), there was serious bad blood between this newspaper and that other newspaper in the Batcave on South Congress. Both of us were growing and flexing our muscles, and the alt-weeklies of our generation were at their peak power within the media landscape all over the continent, and part of being an “alt” was being an alternative to the mainstream media, and part of being “mainstream” was presenting yourself as inherently more credible and trustworthy than those opinion-riddled free

weeklies. (The fact that we were free and the Statesman was not, they said, proved we were crap, because you get what you pay for and whatnot. It was a simpler time.)

Today, all news has become free, which has obviously hurt the daily more than us, and nobody wants to pay what people used to pay for ad space in print media, which is a tide that has swamped all boats. So both of our papers are leaner and probably wiser than we were in the bubbly Aughts. I still think the local City

Hall and Capitol press corps are more collaborative than competitive now, and our relationships are generally respectful.

But that doesn't mean that there will never be an occasion again to stick a pin in the daily's ass in this column space. Indeed, such an occasion – actually, two occasions – has arisen this very week.

“GOTCHA!” IS A KIDS GAME

Both stories that I think the Statesman has handled very badly this week are being covered by the same reporter, but that's beside the point, as he is speaking with the classic “watchdog journalism” voice of local news media; it could have been any number of Statesman reporters over the years. A lot of folks expect the Chronicle to use that same aggro voice, given the

CONTINUED ON P.10

AUSTIN AT LARGE
BY MIKE CLARK-MADISON

THE AUSTIN
CHRONICLE

SUPPORT FREE PRESS

Please consider supporting *The Austin Chronicle*. For just a few bucks, you can help us keep delivering the news.

AUSTINCHRONICLE.COM/SUPPORT

WELCOME BACK STUDENTS!

Bring this AD in for your **FREE** Welcome Back **GIFT**

DISCOVER

PLANET K
GIFTS

"AUSTIN'S BEST" SINCE 1990

www.PLANETKTEXAS.com



 **DON'T FORGET OUR**
FREE TEXAS
FIREWORKS
HALLOWEEN MON. OCT. 31 @ 9:30PM
EAST OF PLEASANT VALLEY RD, BEHIND KREIG FIELD

12 AUSTIN LOCATIONS

NEW STORE
CEDAR PARK
BELL
1511 N. BELL BLVD
259-2222

COX PLAZA
10938 RESEARCH
342-9088

GUADALUPE
3700 GUADALUPE
371-1920

COLORADO RIVER

SOUTH
1516 S. LAMAR
443-2292

TRADING POST
BEE CAVE
HWY 71 & BEE CAVE RD
263-9945

STASSNEY
727. W STASSNEY
707-9069

ROUND ROCK
EXIT 250 N
252-2080

NORTH
RUNDBERG EXIT
832-8544

MANOR RD
2409 MANOR RD
474-2010

CESAR CHAVEZ
3111 E. CESAR CHAVEZ
247-2222

ONION CREEK
EXIT 225 S / 226 N
233-4300

Think Global! **OPEN TIL MIDNIGHT 7 DAYS A WEEK** Shop Local!

The former *Statesman* headquarters on South Congress, aka the Batcave

COURTESY OF MICHAEL BARERA

AUSTIN AT LARGE CONTINUED FROM P.8

alt-weeklies' oppositional stance toward authority and embrace of structural progressive change in our communities. But we think life in Austin is interesting enough as it is, without us creating drama needlessly. We already have a voice; we just need to tell the true story.

Not so at the daily, which tried very hard in the lead-up to Council's adoption of the fiscal year 2023 budget last week (see p.12) to create drama, division, and scandal over our City Hall leaders and their **40% pay raise**. (There's even video of this earth-shattering event: "Watch Austin City Council vote to give themselves \$33,000 pay raise.") As we note this week, this constituted a 0.008% increase in the "all funds" budget, costing each and every Austin taxpayer and ratepayer about a quarter. (A market study found all the City Hall staff are underpaid, they got raises, and Council pay was indexed to that of staff.) Headline-scanning Austinites saw this storyline beaten into hamburger over several days, but learned little about the rest of the \$5 billion budget. We thought it was interesting enough to have written several thousand words about the budget in the last few weeks. But mainstream editors and producers assume readers and viewers will tune out anything with numbers, unless you make them angry about the numbers. And so they tried.

That may be a sad truth about Americans but it kinda sells Austinites short. And let's be honest: The precipitous decline in the *Statesman's* long-term outlook is not entirely unrelated to the fact that hundreds of thousands of people moved to

Austin expecting it to have a well-informed, well-written, and influential daily newspaper, because Austin is a smart city that punches above its weight, and for many years they were sorely disappointed.

ANOTHER SIDE OF THE STORY

One of the big factoids from the FY23 budget drop is that something like 1 in 6 of all city jobs is now vacant, after lockdowns and the Great Resignation and the retirement bulge that the city has been warning about for years. That applies to the city clerk as well, which announced it wouldn't be able to timely verify the 33,000 signatures submitted by Equity Action to get its Austin Police Oversight Act on the November ballot. (The clerk sampled 8,000 signatures to verify but only got through 4,000.) Advocates were disappointed, but neither they nor our reporters here were taken aback or felt misdeeds had been done. They're short-staffed! It checks out.

The daily, however, states unequivocally that Equity Action "failed to make a crucial deadline" to turn in its signatures, and was thus "disqualified" from the ballot, "stripping Austin voters of the chance" to weigh in. It does not provide any information to support throwing thick shade directly at "a group of police reform activists." Like, what was the deadline to turn in the signatures? The *Statesman* does not say. (Equity submitted the sigs on Aug. 8; this story appeared in the daily Aug. 22.) The daily is less fond of these activists, and more fond of their police union sparing partners, than are we. That doesn't excuse not getting basics right. ■

Meetings, Meetings, Meetings

The fall schedule is heating up

Next Thursday, Sept. 1, marks the first post-budget **City Council meeting**, and there's a lot of business to cover: There are some **38 contracts** to be approved (\$1.4 million for Downtown wayfinding, \$400,000 for "a web-based integrated business intelligence suite," etc.); **22 public health initiatives** and agreements; the proposed creation of the **East Sixth Street Local Historic District**; a resolution to reinstate APD's **license plate reader program**; a possible showdown over expanding **parkland dedication fees**, which Mayor **Steve Adler** and Council Member **Natasha Harper-Madison** have indicated they'll oppose; second reading of the **Statesman PUD ordinance** – among the 30 public hearings on zoning cases – and so much more. Plus don't forget, it's **DJ Bling Foundation Day** and **Raza Unida Party Day!** Should be fun! After that, there are just eight more meetings in the Adler era.

PUBLIC NOTICE
BY NICK BARBARO

After Monday's candidate filing deadline, the local election season is now officially underway. See the news feature on p.18 for a first look at the final lineups, and for a deeper dive, the city just released the calendar of **council candidate forums**, co-sponsored by the city, the Ethics Review Commission, and the local **League of Women Voters**; each can be viewed in person, online, on TV or radio, or by phone, and you can email forum@lwaustin.org to propose questions to ask the candidates; see more info at austintexas.gov/candidateforums.

District 1: Thu., Sept. 8, 6pm at Asian American Resource Center, 8401 Cameron

District 5: Thu., Sept. 22, 6pm at South Austin Senior Center, 3911 Menchaca Rd.

District 8: Thu., Sept. 22, 7:30pm at South Austin Senior Center, 3911 Menchaca Rd.

District 3: Thu., Oct. 6, 6pm at Conley-Guerrero Senior Activity Center, 808 Nile

District 9: Thu., Oct. 20, 6pm at City Hall, 301 W. Second

Mayor: Thu., Oct. 20, 7:30pm at City Hall, 301 W. Second

But even before then, the forum season has already started. **University Democrats** is holding a mayoral candidate panel for their first meeting of the semester as we go to press Wednesday evening. The **neighborhood associations within District 9** will co-sponsor a candidate forum at 7pm, Sept. 19, at Griffin School, 5001 Evans, that'll be open to the public either in person or via Zoom. And there'll be many, many more to come.

As you may have heard, the Texas Department of Transportation is planning a massive **rebuilding of I-35**, throughout Central Austin – removing the upper decks, lowering the freeway below grade, and reconfiguring the access roads Downtown to allow the city to come in and cover parts of the freeway with ground-level "caps and stitches" – creating valuable new Downtown real estate while finally bridging the divide between East and West Austin (now that East Austin is gentrified and trendy). So, a group called **Our Future 35**, "a community-centered effort to co-create new public spaces over I-35," is holding an open house with the city this Saturday, Aug. 27, "to inform the public about these plans and collect feedback." The event is from 10am to 2pm (first presentation at 11am) at **Native Hostel**, 807 E.

Fourth, and will include local artists curating interactive stations that will explore potential themes and goals for the program. There will also be an online option; see austintexas.gov/ourfuture35 for details and more info on the project.

Meanwhile, the **Cherrywood Neighborhood Association**, on behalf of near-north residents, has been pushing for "a North-Central Deck to cover I-35 from 32nd to 38th^{1/2} Streets, which could offer similar amenities," and they'll be advocating for that at Saturday's meeting; see more about that at cherrywood.org/i35capex.

Clear the Shelters is an event this Saturday, Aug. 27, at the **Austin Animal Center**: They're waiving all adoption fees and hoping to adopt out 100 dogs to make sure they can provide appropriate shelter for everyone who's left. Last Friday, they had 61 dogs staying in crates. It's 9am-6pm at the AAC, 7201 Levander Loop; you can view adoptable pets online at austininanimalcenter.org. ■

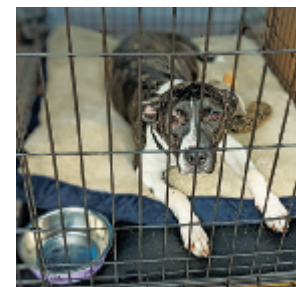

Send gossip, dirt, innuendo, rumors, and other useful grist to nbarbaro@austinchronicle.com.

If you are **turning 65**, it's time for an important choice.

Signing up for Medicare.

WellMed helps you feel your best for your next journey!

WellMed has been helping older adults feel their best for more than 30 years, and our health care approach is tailored for people turning 65.

What's different about WellMed?

- Personalized, primary care with access to specialists who share our preventive care philosophy.
- Same-day appointments available when necessary, so you can get care as soon as you need it.
- Locations offer 24/7 support including online providers, so you can always reach someone from your clinic.
- In-person, curbside or online appointments offer you safe, convenient choices to access care your way.

We can help you live healthier and stay well all year long.

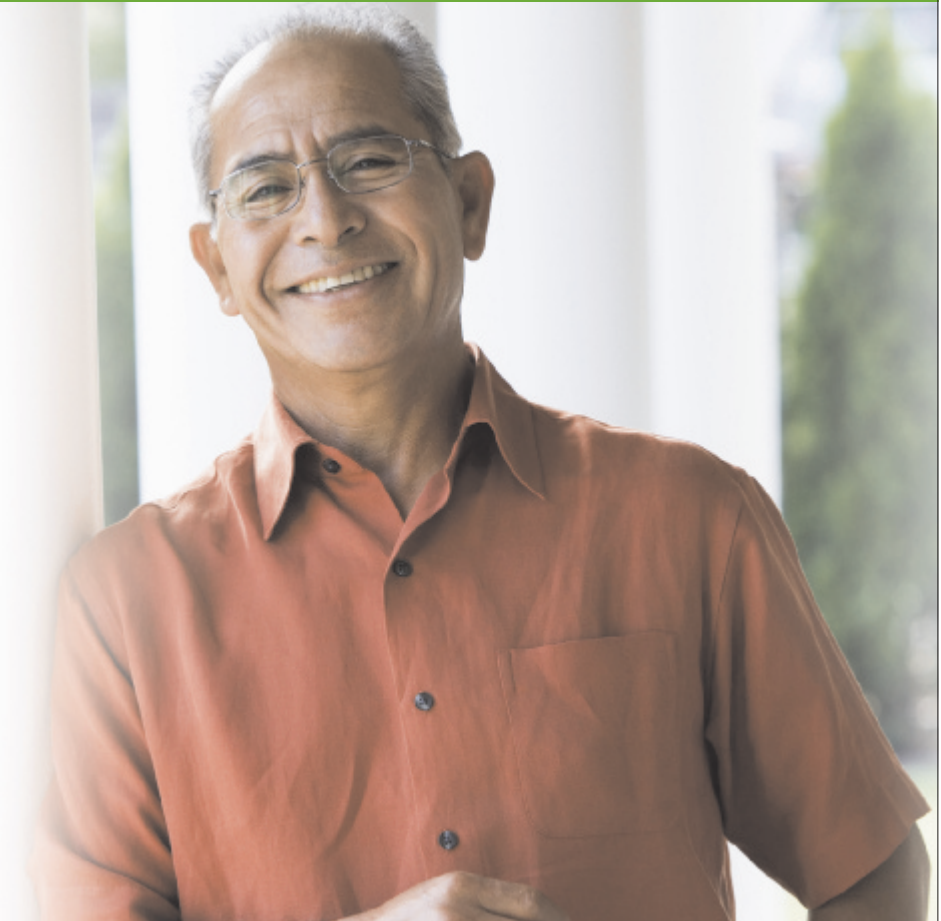

Scan this code with your
smartphone camera to
connect with us online



Connect Now.

discoverwellmed.com/t65

1-512-831-5319*

*Calling this number will direct you to The Brokerage, License #2359, a licensed insurance agent.
A licensed insurance agency works with Medicare enrollees to explain Medicare Advantage,
Medicare Supplement Insurance, and Prescription Drug Plan options.

The stock image is being used for illustrative purposes only.

The company does not discriminate on the basis of race, color, national origin, sex, age, or disability in its health programs and activities. We provide free services to help you communicate with us such as letters in other languages or large print. Or, you can ask for an interpreter. To ask for help, please call 888-781-9355. ATENCIÓN: Si habla español (Spanish), hay servicios de asistencia de idiomas, sin cargo, a su disposición. Llame al 888-781-9355. 請注意：如果您說中文 (Chinese)，我們免費為您提供語言協助服務。請致電：888-781-9355。

Money in My Pocket

City base wage jumps to \$20/hour in FY 23 budget

BY AUSTIN SANDERS

After two long days of deliberation, City Council gave final approval late in the evening Thursday, Aug. 18, to a \$5 billion “all funds” **fiscal year 2023 budget**. The General Fund, which is where your sales and property taxes go, accounts for about \$1.3 billion of that budget, with more than 60% of that amount earmarked for public safety.

Council approved a property tax rate of 46.27 cents per \$100 of taxable value, which is right at the 3.5% maximum increase in total property tax revenue (the “revenue cap”) allowed under state law and about 8 cents lower than the current year’s tax rate. The new tax rate on its own will not increase tax bills for homeowners, but combined with rate and fee increases for city services, the owner of a median-price home in Austin (\$453,727) will pay an additional \$169.68 in taxes and fees per year.

The biggest change Council made to the budget proposed by City Manager **Spencer Cronk** a month ago was to further increase the base wage offered to city workers. Cronk’s budget would have boosted the **city minimum wage** from \$15 per hour (though no current city workers still earn that base wage) to \$18 per hour, along with offering a 4% **cost-of-living adjustment** to everyone higher up the pay scales.

But a broad coalition of progressive advocates, ranging from labor groups to criminal justice reformers, were campaigning for an increase to \$22 per hour. Council met them in the middle; Council Member **Vanessa**

Fuentes carried a budget amendment that allocates \$7 million toward increasing the city minimum wage to \$20 per hour (while maintaining the 4% COLA for everyone else). The amendment also requires staff to craft a plan for annual pay increases that will boost the minimum wage to \$22 per hour as quickly as possible.

“A \$20/hr living wage will provide Austinites with reliable and high-quality city services while also enabling our public employees to live in the city they serve,” Fuentes wrote in a statement following Council’s adoption of the budget.

“High-quality city services” is a bit of a veiled reference to the dire staffing crisis facing practically every city department. Data from May shows a roughly 16% vacancy rate across all departments – about 2.5% of which had been vacant for more than a year.

The minimum wage hike, which will be permanent and take effect Oct. 1 when the new fiscal year begins, is an attempt to boost city recruitment efforts and decrease those vacancy rates. But, as staff indicated during the two-day Council meeting, the \$7 million will be enough to raise the minimum wage and cover the 4% COLA, but may not be enough to further increase pay for employees who earn \$20 per hour or more.

The city’s **Human Resources Department** refers to this as “pay compression,” which is what happens when pay at the lower end of the pay scale increases without a commensurate increase



Vanessa Fuentes on Aug. 3

JOHN ANDERSON

to the higher ends of the pay scale. As HRD Director **Joya Hayes** explained to CMs earlier this week, the “living wage” budget amendment will create a situation where crossing guards will be earning nearly as much as those positions that were already being marketed at \$20 per hour (i.e., 33% above the prior base wage).

While higher starting pay will help with recruitment, pay compression will have a negative impact on employee retention, with which the city also struggles. So, HRD is going to work with department heads across the city to see how they can address pay compression. For some departments, like **Parks and Recreation**, they’ll be able to use some of their share of the \$7 million to increase pay for more employees, because many PARD jobs are seasonal but are

funded for the full fiscal year. Every department will be able to use some of their “**vacancy savings**” – i.e., the money left over in their budgets from unfilled-but-funded positions – to address compression. After all that accounting is completed, HRD will work with the Budget Office to see how much of the \$7 million is left; if more funding is needed, staff will return to Council with a mid-year budget amendment designed to close the funding gap, whatever it may be, to resolve pay compression.

But what about **sworn public safety employees** who staff the city’s first responder agencies? Police and firefighters haven’t gotten any raises yet; their unions are still in **contract negotiations** with the city over pay and benefits. (Medics have agreed to a new one-year contract; see

SHORT-TERM CONTRACT LOCKS IN BIG WAGE GAINS FOR EMS

After nine months of talks, the city and the **Austin Emergency Medical Services Association** have reached an agreement on a pay and benefits proposal to be included in a new labor contract for medics at **Austin-Travis County EMS**.

Currently, entry-level **emergency medical technicians** (EMTs) earn \$19.25 per hour; the new contract will increase that to \$22 per hour, the base wage to be offered to all other city employees as soon as city budgets allow. AEMSA leadership kicked off negotiations with a call for starting pay of \$27, which they say would keep the agency competitive with private ambulance companies in the area. That would amount to a 40% wage increase in a single contract, which would be a hard sell at any time. It’s especially so when the city, which

does not expect to be as flush with cash in future years as it is now, is also in talks with the police and firefighter unions.

Austin EMS **paramedics** – a higher rank than EMT – will also see a more-than-10% pay bump, increasing from \$26.67 per hour to \$30. Addressing paramedic pay compression was a critical requirement for the contract for many medics. With a workforce demoralized by two years of pandemic working conditions and years of ineffectual leadership, front-line employees feared that failing to increase paramedic pay would result in more of the agency’s skilled employees departing for the private sector. Currently, 23% of all positions at Austin EMS are vacant; 58% of those are paramedic positions.

All other EMS employees will get at least a 4% pay increase (the cost of living adjustment for all city employees in the just-adopted 2023 budget). The EMS pay proposal comes with a \$4.2 million price tag – a relatively small figure, because the city and AEMSA are only agreeing to a one-year contract for the fiscal year, which ends Sept. 30, 2023.

Typically, the city’s public safety union contracts last four years. But the shortened contract allowed AEMSA to secure the increased wages for EMTs and paramedics – easily the most pressing issue among front-line medics – without locking in three years without wage increases to follow. Instead, the union hopes to return to the table in a year and work out more favorable terms. City Council is expected to vote on the agreement with AEMSA at the Sept. 1 meeting; AEMSA members will begin voting to ratify the agreement today, Aug. 25, through Monday, Aug. 29.

– Austin Sanders

below.) That poses more challenges to the city's HR and budget professionals. It's more than possible that, midyear, Council will need to adjust its budget thinking to accommodate more expensive contracts.

And if you've kept up with budget coverage at the daily, you've likely already read the shocking headline – CMs voted to give themselves a **40% raise**. (The vote was 8-3, with Fuentes, **Mackenzie Kelly**, and **Paige Ellis** – who is up for reelection this year, the other two in 2024 – in opposition.) Scandalous! Except that CM salaries haven't increased (aside from the same COLAs that all city employees received) since 2006. Even with the raise, CMs will earn less than Travis County commissioners.

A market study conducted by HRD and Gallagher Benefit Services found that **Council staffers** make about 14% less than their peers (San Antonio, Denver, and Phoenix were among the 13 benchmarked cities). The new wage scale will place Austin staffers at 5% above the market average; since that would mean CM's chiefs of staff would earn more than their bosses, HRD proposed boosting CM pay, too, to 10% above that of the highest-paid staffers.

The end result is a new CM salary of \$116,688 and mayoral salary of \$134,191

annually (increased from \$83,158.40 and \$97,656, respectively; **Steve Adler** has not drawn a salary his entire time in office, instead using his foregone pay to increase the mayor's office staff). Council also voted to allow CMs to participate in the city's **retirement system** for the first time. All told, the compensation and benefits increases for Council offices will cost the city about \$395,000 per year, or .008% of the entire budget they oversee.

Other budget highlights include a total of \$8 million in one-time funding that can be used for rental assistance; \$200,000 of that will be set aside to provide inclement weather shelter to the city's unhoused population (the total was increased by \$3 million via an amendment from **CM Chito Vela**); \$17.8 million to complete construction of the **Goodnight Ranch** Fire/EMS station in far Southeast Austin; \$1.2 million to expand a life-saving field treatment program deployed by EMS known as **Whole Blood**, which allows medics to perform blood transfusions in the field; and a total of \$79 million invested in a variety of programs and services meant to **reduce homelessness** in Austin. ■

Council meets next Thursday, Sept. 1; see "Public Notice," p.10, for a brief preview.

QMMUNITY

KEEP
AUSTIN
QUEER

AUSTIN'S QUEEREST NEWS + EVENTS

DRAG SHOWS
QUEER PARTIES
FILM SCREENINGS
AND MORE

AUSTINCHRONICLE.COM/
QMMUNITY

FIND US ONLINE FOR COVERAGE AND TO SIGN UP FOR OUR WEEKLY NEWSLETTER

THE AUSTIN
CHRONICLE

Safety is our number one concern.
Please call for an appointment first! Thank you! Stay safe!
MON-FRI: 7AM-8PM | SAT: 8AM-3PM | SUN: TEMPORARILY CLOSED



\$29.95 PET EXAM

Offer valid for dogs & cats only. Not valid for emergencies.
Offer expires 9/2/22. Must present coupon at time of arrival.



\$124.99 ANNUAL VISIT

Dogs Includes: Exam, Distemper-Parvo, Rabies, Heart-Worm Test, Intestinal Parasite Check

Cats Includes: Exam, Feline Distemper, Rabies, Feline Leukemia and Intestinal Parasite Check

Offer valid for each pet. Offer expires 9/2/22. Must present coupon at time of arrival.



LOW COST ROUTINE SPAYS & NEUTERS FOR CATS & DOGS

Dog Spay/Neuter: 0-45 lbs. - \$140/ 45.1-100 lbs. - \$180
Cat Spay: \$120

Not redeemable for cash. Applies to routine spays & neuters.
Offer valid for each pet. Offer expires 9/2/22. Must present coupon at time of arrival.



\$95 CAT NEUTERS!

Valid for routine cat neuters only. Offer valid for each pet.
Offer expires 9/2/22. Must present coupon at time of arrival.

Wells Branch & South Branch Pet & Bird Clinic

Savita Wadhvani, D.V.M.
12202 NORTH MOPAC
512-339-8472

Ayalsew Mekonnen, D.V.M.
Kishor Patel, D.V.M.
403-F EAST BEN WHITE
512-462-0002

WE NOW ACCEPT CARECREDIT! SE HABLA ESPANOL

Find Us Online: **PETANDBIRDCLINIC.COM**

SUPPORT FREE PRESS

Please consider supporting *The Austin Chronicle*. For just a few bucks, you can help us keep delivering the news.

THE AUSTIN
CHRONICLE

AUSTINCHRONICLE.COM/SUPPORT



Your Downtown, Central,
East Austin Real Estate Expert

512-801-0436

carrie@austinrealpros.com www.carrieyork.com

Sales, leasing, & property management

Austin Real Pros, REALTORS®

The Plot Thickens

Kaitlin Armstrong defense team calls police narrative “misogynistic and fictitious” **BY MAGGIE G. THOMPSON**

The case police have built against Austin yoga instructor **Kaitlin Armstrong** in the murder of a young rising-star cyclist sounds like the plot of a mystery novel. It centers on motive: Armstrong and **Anna Moriah “Mo” Wilson** were in love with the same man, **Colin Strickland** (also a well-known cyclist), but Armstrong had him first.

That Armstrong fled the country a few days after the murder – dyed her hair, used a fraudulent passport, and ended up on an idyllic beach in Costa Rica for more than a month while authorities in the U.S. searched for her – may seem a de facto admission of guilt. Her defense team doesn’t refute that she left the country using a new identity, but in a **178-page motion** filed Aug. 18, they took aim at almost every other piece of evidence. On Friday, Aug. 19, they told District Judge Brenda Kennedy they’re ready for her to consider these motions now. After another flurry of motions this week, which saw both sides calling for gag orders, prosecutors and Armstrong’s defense team said during a Wednesday, Aug. 24, Zoom hearing that they’d signed an agreement that would bar both sides from making prejudicial comment to the media (rather than *all* comment). Kennedy had yet to sign on to the agreement Wednesday morning, but said she was “glad we were all able to move in a positive direction.” What the Wednesday hearing did not cover was the explosive motion from Armstrong’s defense that accused police of lying repeatedly to form a case against her.

That motion, obtained by the *Chronicle*, asserts that the police affidavit was full of “lies, mischaracterizations, and reckless disregard for the truth.” It also includes the transcript of the lengthy police interview with Colin Strickland, as well as pieces of Armstrong’s own interrogation (excerpts available at austinchronicle.com).

Here’s what both sides agree on. While 25-year-old Wilson was staying at a friend’s house in Austin (ahead of a race in Dallas a few days later), she and Strickland went on a secret swimming date. Police allege the evidence suggests that Armstrong followed Wilson into her home and shot her twice in the head and once in the chest, then quickly fled, returning home in time to meet up with Strickland less than an hour later.

Armstrong’s defense counsel says there’s *no* good evidence, and police know it, despite claims made in the affidavit: No, a test fire did *not* show that there was a “significant” potential that Armstrong’s gun and the casings found near Wilson’s body matched. No, Armstrong did *not* nod when detectives said maybe she’d been hanging around Wilson’s home because she was upset. No, Strickland did *not* say Armstrong blocked Wilson in his phone. No, a car like Armstrong’s was *not* seen near Wilson’s house one minute after Wilson arrived home – the detective later found that a security camera’s time stamp was wrong, and took more than 50 days to update the report. No, an anonymous female caller’s account that Armstrong was shaking with rage and said she wanted to kill Wilson was *not* credible – a second anonymous caller said he was present during the same conversation the first caller had described, but Armstrong didn’t seem furious and didn’t say she wanted to kill Wilson.

And no, a neighbor did *not* observe a bike speeding away from Wilson’s place the night of her death. Actually, he told police he was high the night of the murder and said, “I may or may not have imagined the whisking bike part and having the impression of a southbound bike. But I, it’s like ... actually hard for me to testify in a court of law to that only because like I didn’t fucking see it and it could be my imagination. ... Like the whole thing about me saying there was a bike? Like I don’t fuckin’ know for sure.”

Armstrong’s attorneys, **Rick Cofer** and **Mark Pryor**, conclude: “[APD] Detective [Richard] Spittler concocted a misogynistic and fictitious story portraying Ms. Armstrong as a jealous woman scorned by Mr. Strickland.”

The affidavit that led to Armstrong’s arrest lays it out like this: On May 11, 2022, just before 10pm, police found Wilson dead in the bathroom of a friend’s home in East Austin. Based on texts, interviews, and phone alerts delivered every time the friend’s door unlocked and locked, police believe Wilson left just before 6pm to swim with Strickland, a well-known racer who had been sponsored by Red Bull and other brands and was in a three-and-a-half-year relationship with Kaitlin Armstrong, with



Austin police interviewed Kaitlin Armstrong May 12 without mirandizing her

IMAGE VIA PUBLIC DOCUMENTS

whom he shared a home. She returned just after 8:30pm.

When police questioned Strickland on May 12, he spoke highly of Armstrong. He said they’d broken up briefly in October, Wilson had visited, and he and Wilson dated. He said Armstrong may have blocked Wilson’s number in his phone. He said he did go swimming with Wilson on May 11 and lied to Armstrong about where he was going.

And Strickland told police he drove Wilson home on his motorcycle and dropped her off around 8:30pm. At 8:36pm, Strickland texted Armstrong, “Hey! Are you out? went to drop some flowers for [a sick friend] at her sons [sic] house up north and my phone died. Heading home unless you have another food suggestion.” (Shortly thereafter is when police had believed a neighbor’s doorbell camera captured a black SUV with a bike rack similar to Armstrong’s near Wilson’s house.)

Then, at 8:48pm, Strickland was recorded driving near the 4900 block of the southbound I-35 frontage road, about a 10-minute drive from where Wilson was staying. Strickland told police Armstrong arrived home around 9:20pm.

The affidavit lays out other facts that it says point to Armstrong: the casings, the anonymous caller who said Armstrong was “shaking” with anger, the neighbor who saw a bike speed past, Armstrong’s nodding during her brief interview with police.

The defense motion states that a video of her brief interrogation on May 12 (after being picked up on a 2018 warrant for theft of services) showed Detective Katy Conner

saying, “Maybe you were upset and just in the area,” at which point Armstrong did not move her head. When Conner added, “I don’t know, because I don’t have your story,” then Armstrong slightly nodded.

One of the more complicated truths to unravel is what exactly Strickland’s two police interrogations tell us about the case. While Strickland did say he suspected that Armstrong had blocked Wilson’s number in his phone, he also repeatedly told officers it could have been a glitch on his phone. While he described her as occasionally jealous, he also said her jealousy was “normal” and that she was “one of the least volatile women I have dated in terms of emotion over up – upwelling of, like, anger and jealousy and emotion.” He did describe the two breaking up in October, but said Armstrong was dating other people herself during that time and didn’t seem upset. When pressed repeatedly about Armstrong’s anger and potential to kill, Strickland said, “I cannot fucking fathom it. I cannot fathom it,” and, “This is not possible in my experience of three years spending every – virtually every day with this person.”

Strickland also told detectives repeatedly that he could tell they were trying to create a “narrative” that paints Armstrong as jealous, but he didn’t want to be part of it. When a detective left the room during his second interrogation, Strickland’s attorney asked, “Is there something that you wanted to say last time that you don’t feel like you got to say?” Strickland responded, “I have something to say. Fuck you guys for manipulating me.”

May 11 Timeline

-5:30PM Mo Wilson's friend and host leaves their residence at 1708 Maple Ave.

-5:45PM Colin Strickland arrives to pick Wilson up for swimming, per his account 5:55pm ... Door at Maple Avenue locks, indicating Wilson had left

8:16PM Strickland and Wilson leave Pool Burger on Strickland's motorcycle, per camera

8:35PM Strickland's motorcycle arrives in an alleyway near Wilson's Maple Avenue home, per camera

8:36PM Door at Maple Avenue unlocks with unique code; Strickland texts Kaitlin Armstrong, "Hey! Are you out? went to drop some flowers for [a sick friend] at her sons [sic] house up north and my phone died. Heading home unless you have another food suggestion."

8:43PM Dark-colored SUV with a bike rack travels near Maple Avenue home (police originally believed the SUV arrived at 8:37pm, but time stamps were later found to be six minutes off)

8:48PM Strickland's motorcycle drives down the 4900 block of southbound I-35 frontage road

-9:21PM Armstrong arrives home at 5301 Fort Clark Dr., per Strickland's account

9:56PM Police respond to residence and find Wilson dead

Excerpts from the transcripts of Colin Strickland's police interrogation and Kaitlin Armstrong's brief interrogation are available online at bit.ly/3R39d8w.

USED,
COLLECTIBLE,
and UNIQUE

SOUTH
congress
BOOKS

1608 S. CONGRESS AVE.

512-916-8882

southcongressbooks.com

SUNDAY-THURSDAY 11AM-6PM
FRIDAY & SATURDAY 11AM-7PM

KEEP
AUSTIN
REAL

Support
free press.
Advertise with us.

THE AUSTIN CHRONICLE

KIDS ARE GOING BACK TO SCHOOL

LET'S GIVE BACK TO OUR COMMUNITY

Meals on Wheels is Looking for Lunch

Time Delivery Drivers.

Deliveries take less than 1 hour.

Apply Online Today: mealsonwheelscentraltexas.org



PINBALLZ
EAT • DRINK • PARTY • PLAY

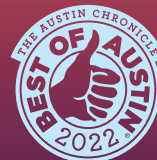

AUSTIN'S BEST
PARTY PLACE!

- Birthday Parties
- Corporate Events

PINBALLZ.COM

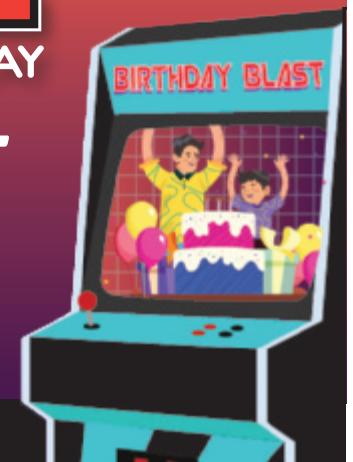

Happy Birthday LBJ!

CELEBRATE LBJ'S BIRTHDAY
AT THE LBJ LIBRARY & MUSEUM

— AUGUST 27, 9 AM - 5 PM —

FREE ADMISSION & PARKING
CUPCAKES, CRAFTS, BUTTON-MAKING

LBJLIBRARY.ORG

Ever-Rising Rent

City hamstrung as renters face crippling costs

BY ABE ASHER

A spate of new data continues to illustrate just how serious the rent affordability crisis remains in Austin, though it's cooled slightly since the spring. In July, the average rent for a one-bedroom apartment increased by more than 28% over July of last year, per Rent.com data – more than in any large city in the U.S. with the exception of Phoenix. In June, as Bloomberg reported, Rent.com found that the average rent for a one-bedroom in Austin had spiked to \$3,257 (a 108.23% year-over-year increase from June 2021), which seems to demonstrate either how wild rent is in Austin or how hard it is to accurately keep track of.

The average rent in Austin also remains higher than anywhere in Texas except Frisco, a Dallas suburb with nearly twice the median household income of Austin and a fraction of the rental stock.

“It’s amazing to me that landlords and property managers are expecting people to be able to afford a place to live while their rates are going up, but people are getting paid the same thing they were 10 years ago,” said Chas Moore, executive director of the Austin Justice Coalition.

Remarkably, this latest data from Rent.com qualifies as relatively good news: It shows Austin’s rental market cooled somewhat this summer following a spring of even more dramatic price increases. Between April of this year and April of last year, for instance, Rent.com found the average one-bedroom

rent more than doubled. Certain neighborhoods have been more greatly affected than others: Average rent in Central Austin is up a whopping 250% from this time last year, while average rent in Hancock is up 79%. Meanwhile, Northeast Austin is seeing similar rents to last July and Bouldin Creek’s average rent has only risen 13%.

The housing market in Austin has been similarly hot, but the correlation between the rental and housing markets remained strong last month. According to the Austin

Board of REALTORS, the year-over-year rate of increase in sales prices dropped to single digits in July for the first time in more than two years as the price of the average house in the Austin metro area rose just 8% to \$515,000.

Of course, stable housing at those price points remains out of reach for many in Austin – including many longtime, non-white residents of the city who have seen their neighborhoods gentrify and dramatically increase in price. It has also badly affected younger people. According to data from the U.S. Census Bureau, the median annual wage for millennial renters in Austin is \$41,885. With rent for one-bedrooms costing \$1,503 on average in July, per Rent.com, the annual wage required to afford a one-bedroom rental without spending more than 30% of income on rent is \$54,108.

“We’re still seeing the struggle,” Nora Linares-Moeller, executive director of HousingWorks Austin, said. “[The market]

has cooled a little bit, but not enough. There’s still a crisis based on inventory, based on increases of housing costs, based on the issue of some of the houses being bought up by corporations to be used as investments ... I think we’re seeing all of those things still happen.”

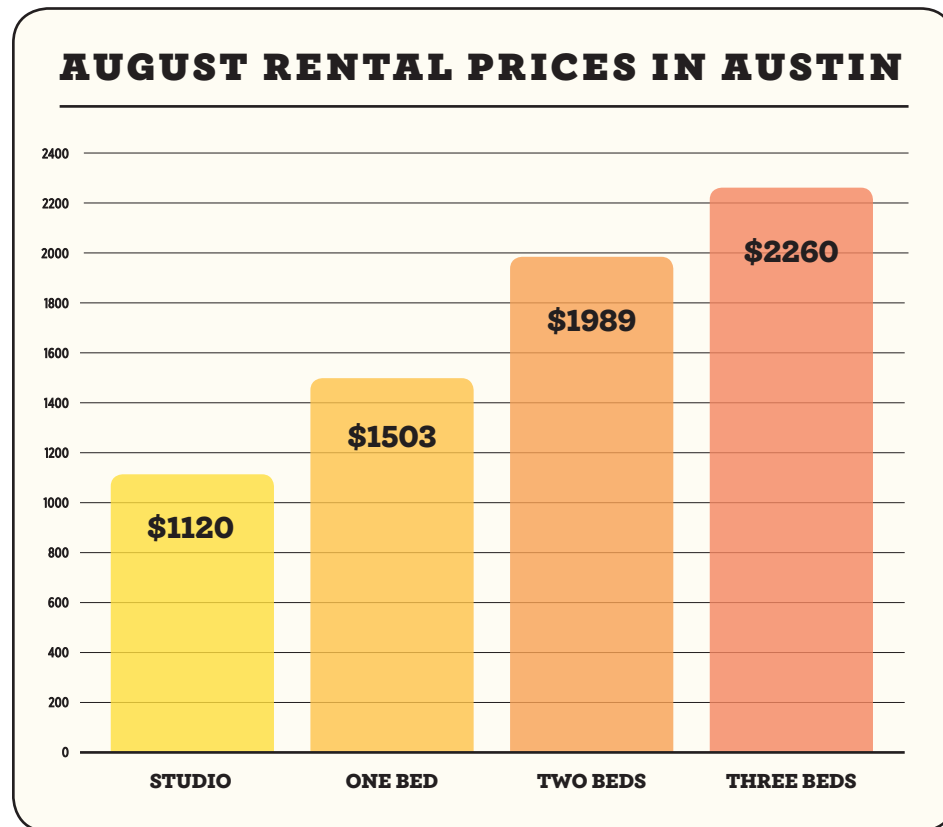

Rent increases have cooled some in Austin but remain some of the most severe among all U.S. metros

SOURCE: RENT.COM, UPDATED AUG. 22

“It’s amazing to me that landlords and property managers are expecting people to be able to afford a place to live ...”

AUSTIN JUSTICE COALITION’S CHAS MOORE

Lewis Conway Jr., 1970-2022

Lewis Conway Jr., the East Austin native who inspired left-wing activists across the city through his advocacy for the rights of formerly incarcerated people, died last week. Conway served an eight-year prison sentence and 12 years of parole after fatally stabbing a man in 1991. Following his release from prison, Conway devoted his career to criminal justice reform. In 2018, he pushed the boundaries of Texas law by running for the District 1 Austin City Council seat; before that, he helped pass Austin’s Fair Chance Hiring ordinance. After the 2018 City Council campaign, Conway went on to work as a national campaign strategist for the American Civil Liberties Union in New York. He was also an ordained minister, published author, and motivational speaker.

— *Austin Sanders*



JANA BIRCHUM

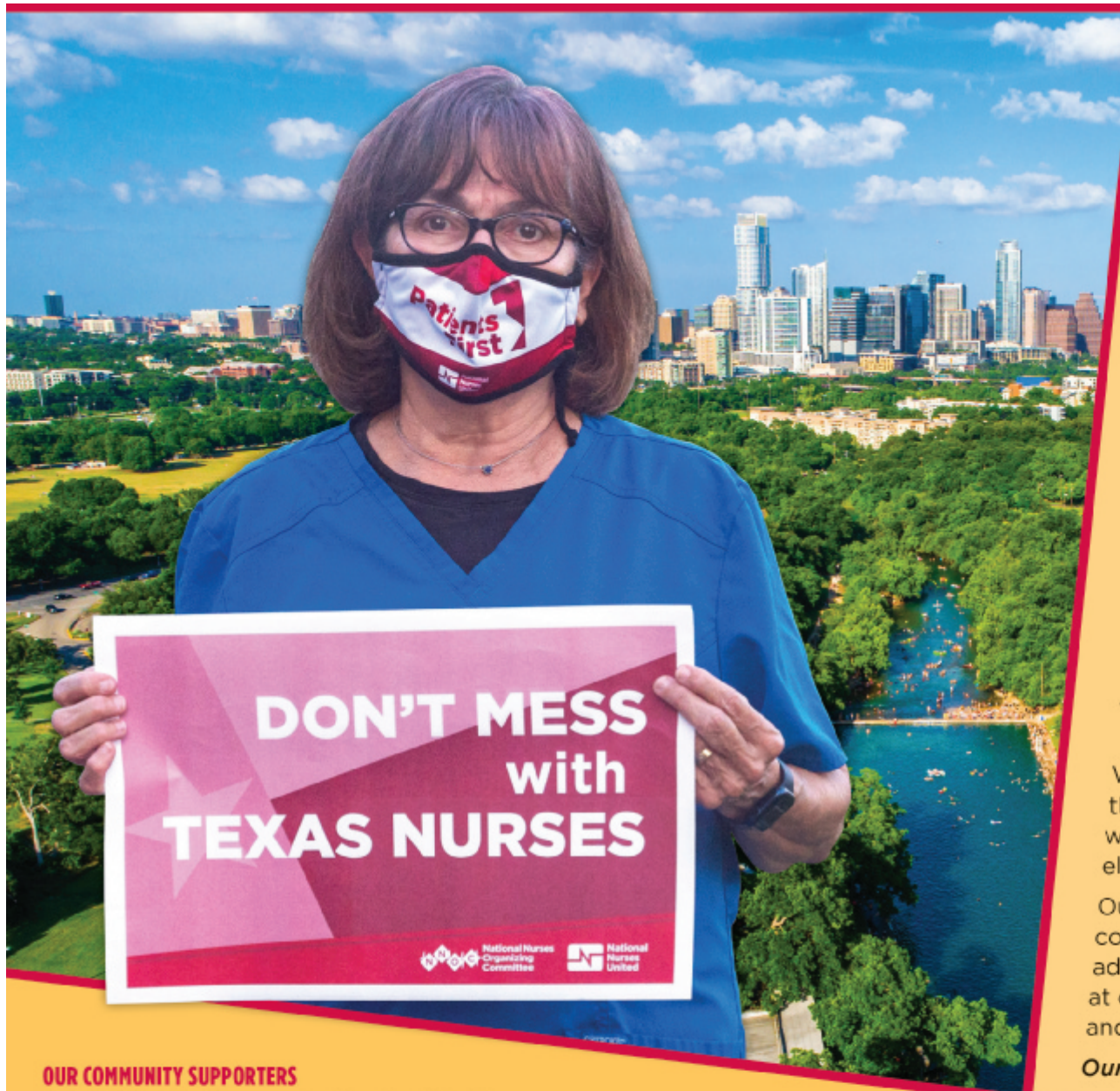

We Support the Nurses of Ascension Seton Medical Center Austin as They Bravely Form a Union

When nurses have a collective voice, patients are protected. Seton RNs deserve:

- Safe staffing standards to provide us the kind of optimal, quality care nurses want to give.
- A real voice in decisions that in their lives at work and the lives of their patients.
- Standards that recruit and retain RNs at the bedside.

We urge Ascension administration to respect the right of nurses to decide for themselves whether to form a union in a free and fair election, as guaranteed by federal law.

Our families, our neighbors, and our community all rely on Seton nurses to advocate for us when we are sick, injured, and at our most vulnerable. Let's in turn respect and support their voice.

Our safety and well-being are in their hands.

OUR COMMUNITY SUPPORTERS

Beto O'Rourke, Democratic Nominee for Governor

Sarah Eckhardt, State Senator, District 14 • Vikki Goodwin, State Representative, District 47

Gina Hinojosa, State Representative, District 49 • John Bucy III, State Representative, District 136

Brigid Shea, Travis County Commissioner, Precinct 2 • Vanessa Fuentes, Austin City Council Member, District 2

Jose "Chito" Vela, Austin City Council Member, District 4 • Ann Kitchen, Austin City Council Member, District 5 • Kathie Tovo, Austin City Council Member, District 9 • Nathan Ryan, Commissioner, City of Austin • Stephanie Gharakhanian, Austin Community College Trustee • Sean Hassan, Austin Community College Trustee • Greg Casar, Democratic Nominee for US Congress, TX-35; former Austin City Council Member • Mike Collier, Democratic Nominee for Lt. Governor • Janet Dudding, Democratic Nominee for Texas Comptroller of Public Accounts • Jay Kleberg, Democratic Nominee for Texas Land Commissioner • Luke Warford, Democratic Nominee for Texas Railroad Commission • Celia Israel, Austin Mayoral Candidate • Wendy Davis, Community Leader • Texas AFL-CIO • Austin AFL-CIO Central Labor Council • AFGE Local 12 • Austin EMS Association-CWA 6914 • Education Austin AFT Local 2048 Education Round Rock • Ironworkers Local Union 482 • Laborers Local 1095 • LIUNA / SWLDC / Local 1095 • Plumbers and Pipefitters Local 286 • IBEW Local 520 • Texas State Employees Union • St. Austin Catholic Church • University United Methodist Church • Catholic Labor Network • Deeds Not Words Texas Democracy Foundation Board Member • Every Texan United • Texas Fair Trade Coalition • Ground Game Texas • Texas Blue Action • Sunrise Movement Austin • Workers Defense Action Fund • Spacetime Studios • Restora Austin Plastic Surgery • Law Office of Susan Hays, PC



National Nurses
Organizing
Committee



National
Nurses
United

Our Future Is Now

Local elections herald epic changes in the capital city **BY MIKE CLARK-MADISON**

We mention it in passing in the stories in this preview, but it's worth pausing for a sec to fully appreciate it: The upcoming November elections (and their inevitable December run-offs) will see the retirement and replacement of the last pre-10-1 Austin council member (Kathie Tovo) and leave only one member remaining (Leslie Pool) of the first 10-1 council, elected in 2014. For some of you, this was only yesterday, and you remember the issues at play in that wildass election, when all 10 seats were up and 87 people ran. (That's also when Austin voters rejected the previous, now-forgotten version of Project Connect.) For about 164,000 of you and your friends, you didn't live in Austin then and have no idea.

That's a good thing! That 2014 election was sorta disappointing to people who wanted 10-1 to be a clean break from the previous at-large city council, which operated in an



atmosphere of consensus-building so cozy that it ended up violating the Texas Open Meetings Act, and was routinely elected by about 15% of Austin voters. Instead, we ended up turning Austin's political clock back a few years, relitigating things we thought had been decided, reintroducing divides that predated Kirk Watson's 1997 election as Mayor Wonderful. It would take a pandemic, and an explosion of police violence, and a national constitutional crisis, and Austin's endlessly rising cost of living despite all those disruptions, to really remake the Austin civic map.

This is the election when the next era of Austin's saga begins. Will it be one of continued prosperity and sexiness, or will the bottom fall out for real for the first time since 2001? Which of these outcomes should we root for if we'd like to rent a decent apartment? And will Austin withstand the heavy red pressure bearing down on its borders? ■

CITY COUNCIL CANDIDATES

MAYOR

Phil Campero Brual
Celia Israel
Erica Nix
Kirk Watson
Anthony Bradshaw
Jennifer Virden
Gary S. Spellman

DISTRICT 5

Ryan Alter
Bill Welch
Ken Craig
Stephanie Bazan
Aaron Velazquez
Webman
Brian Anderson II

DISTRICT 1

Misael D. Ramos
Clinton Rarey
Melonie House-Dixon
Natasha Harper-Madison (I)

DISTRICT 8

Paige Ellis (I)
Richard Smith
Antonio D. Ross
Kimberly P. Hawkins

DISTRICT 3

José Velásquez
Daniela Silva
Gavino Fernandez, Jr.
José Noé Elías
Yvonne Weldon
Esala Wueschner

DISTRICT 9

Zena Mitchell
Zohaib "Zo" Qadri
Greg Smith
Joah Spearman
Kym Olson
Ben Leffler
Linda Guerrero
Tom Wald

(LISTED IN BALLOT ORDER)

The Next Mayor of Crisis City

Watson, Israel lead pack in funds, reputations, and housing plans **BY AUSTIN SANDERS**

Austin's next mayor will only serve for two years until facing reelection, following a ballot measure approved in May 2021 that moved the mayor's race to the presidential cycle. Given the crisis atmosphere in Austin politics over housing, affordability, and equity, the winner will be expected to accomplish a lot in those two years, hitting the ground running from a campaign that's likely to not end until a December run-off. With Kathie Tovo deciding not to run (though she has hinted at a potential '24 campaign), the two leading candidates are former mayor and state senator Kirk Watson and outgoing state rep Celia Israel. Watson has established himself as a juggernaut in the contest for the job he last held in 2001, with higher name ID (though a recent poll found that after voters learned more about each candidate, the race was a dead heat) and a colossal fundraising advantage. Watson has also locked in key labor endorsements early: the unions representing EMS medics, firefighters, hotel workers, and city of Austin civilian employees have also gone with the former mayor. Watson reported a haul of nearly \$1 million in mid-July, but Israel's \$253,000 intake was still record-breaking and she'll have a shot if she can keep Watson under 50% in November.

However, Jennifer Virden, a far-right Republican who nearly unseated Mayor Pro

Tem Alison Alter two years ago, may play a spoiler in Israel's strategy. Virden did well in the westernmost precincts in Austin, which made her competitive in the District 10 race against Alter, but her views are pretty darn fringe, even by Texas Republican standards. GOP voters only account for about 25% of the Austin electorate, so she has virtually no shot at winning citywide. But her campaign has money, most of which (\$300,000) she loaned herself back in January, so Israel cannot take the threat of being pipped at the post for granted.

Watson and Israel have both rolled out housing strategies in response to what Watson calls an "emergency" and Israel a "historic crisis point." Israel's proposals are anchored in urbanist ideas, with explicit calls for more housing for working families – specifically of the "missing middle" variety, the four- and six- and 10-plexes and live/work units and row houses that are both rare and mostly illegal in Austin – and transit-oriented development along the Project Connect corridors. In what's become a key slogan of her campaign, Israel says, "This election is about who can afford to live here, and who gets to decide."

Watson's plan leans on his reputation as a leader who gets big things done (new City Hall, I-35 rebuild, Dell Medical School, etc.) to tackle reforms not just to land use



I-r: Kirk Watson, Cella Israel



WATSON PHOTO COURTESY OF CAMPAIGN / ISRAEL PHOTO BY JANA BIRCHUM

policies, but to a city permitting process that was beyond broken when he was mayor the first time and has not gotten much better. He wants to incentivize not just developers but his colleagues to create decent housing where Austin needs it; the most controversial plank in his platform would give council members more say in the policies and codes applying to their districts, though he backtracked some when this started being compared to redlining, ward politics, and Jim Crow. Right now, much of Austin's housing is being built east of I-35 and/or on the northern and

southern fringes of town. Read more about Watson's plan at bit.ly/3T98jcx and Israel's plan at bit.ly/3pD75Zx.

As is typical with every mayoral race, 2022 will see a number of long-shot candidates. This cycle includes local fitness influencer and activist Erica Nix (Community Editor James Scott is following her campaign at bit.ly/3KhWXyM); 21-year-old UT student Phil Brual; and Anthony Bradshaw and Gary Spellman, neither of whom intend to do any fundraising. ■

MORE ON P.20

THIS SPACE LEFT
INTENTIONALLY BLANK

LOCAL ELECTIONS PREVIEW CONTINUED FROM P.18

Never-Ending Eastside Stories

Gentrification, affordability shape D1 and D3 races

It's all about housing affordability for José Velásquez, and for most Eastside candidates in this year's City Council races. "Every single person running for Council right now is talking about affordability and that makes me so happy," Velásquez said. "I have just seen my community being decimated by gentrification. And I'm not knocking anybody that wants to live in East Austin, or in District 3, but we have to find a place where we can make it affordable."

Velásquez is the front-runner in the six-person D3 race, with the endorsement of the departing incumbent, Pio Renteria, and much of the Democratic Party establishment. He is the grand-nephew of the legendary Roy Velásquez of Roy's Taxi, an informal advisor to Lyndon Johnson, and his family has been part of the Eastside's political landscape for a century. "I did my first petition when I was 11 years old and I haven't stopped serving my community since," Velásquez said.

Jose Noe Elias immigrated to Austin from Mexico at the age of 8 and lived without documentation for 20 years, earning a master's degree in education. He's a teacher in Montopolis, one the city's most rapidly gentrifying

neighborhoods, and wants to encourage community-centered public safety, equitable transportation, and more housing for working-class families. "The question is, essentially, what kind of housing for whom," Elias said. "If there's [a proposal to build] a five-story complex but my families can't afford it then of course I would be opposed to that."

Daniela Silva is the daughter of an undocumented immigrant and also excelled in higher education. She volunteers with the Austin Justice Coalition, Community First! Village, and others, and supports environmental justice and equity-oriented transit development. Bertha Delgado had mounted a strong campaign that was knocked off course after the city rejected her ballot application due to a 15-year-old nonviolent felony conviction; instead, longtime Holly neighborhood activist Gavino Fernandez, who's run several times over the years and who's been allied with Delgado before, was a late filer on Monday. Yvonne Weldon and Esala Wueschner are also running in D3. Weldon wants to reduce wasteful spending and provide more funding for first responders; we were unable to learn much about Wueschner's priorities. District 3



I-r: Natasha Harper-Madison, José Velásquez, Jose Noe Elias

COURTESY OF THE CANDIDATES' CAMPAIGNS

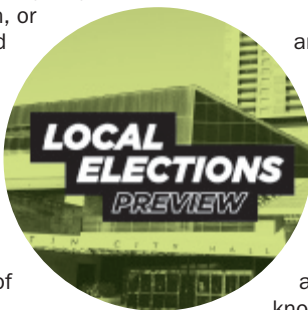

includes Austin's oldest Latinx neighborhoods on both sides of the river, from I-35 at Seventh Street east to Montopolis and south to Ben White, then west of I-35 near St. Ed's.

Meanwhile, in District 1...

Melonie House-Dixon is another candidate with a deep connection to old Austin. As president of the MLK Neighborhood Association, she has fought gentrification but emphasizes that she embraces change. "Most of the development is going on in our area and we welcome development," she said. "We just want to have a voice about what goes up in our neighborhood."

Clinton Rarey, a former Army officer who served in Afghanistan, is one of the few candidates who is not preoccupied with housing.

He's running to reduce the homeless population, hire more police officers, and lower property taxes. We were unable to learn much about Misael Ramos' campaign.

All three of these candidates are waging a very uphill battle to unseat incumbent Natasha Harper-Madison. For her, everything comes back to housing. "When you dig deeper you realize that all of the systemic issues, all of the manifestations of poverty, are directly connected to housing," she said. "Every single time, housing, housing, housing. And I don't separate housing from affordability and I don't separate affordability from mobility. Because they're all directly connected ... so you gotta tackle housing at the same time as affordability at the same time as mobility." — Brant Bingamon

Filling Tovo's Shoes (With Houses?)

Urbanist quartet challenges Guerrero for the D9 hot seat

Kathie Tovo has spent 12 years on City Council, first as an at-large member and then, in 2014, defeating her then-colleague Chris Riley to become the first and only member to represent the central-city District 9. Those years are coming to an end, and the race to succeed her is shaping up as the most fiercely contested of all the council district races, with no clear favorite.

The D9 contest puts into stark relief the political and ideological divides between pro-housing, pro-density urbanists and neighborhood-activist, anti-developer preservationists that have fractured the Council dais for eight years. That's partly because of Tovo's legacy as a champion of the latter camp, who's helped thwart Council's efforts to boost housing production by rewriting the Land Development

Code. D9 includes many of the oldest, most NIMBY-susceptible Central Austin neighborhoods, from Cherrywood, Hyde Park, and Brentwood in the north to Travis Heights, Bouldin, and a bit of Zilker in the south (Tovo began her political career in the 2000s as a neighborhood activist in Bouldin). But it also includes Downtown Austin and Rainey Street, West Campus, and Mueller, Austin's most dense neighborhoods, nationally recognized by urbanists as success stories.

Tovo's pick to succeed her, Linda Guerrero, will be holding up the preservationist banner under the slings and arrows of four of Austin's more prominent urbanists: Joah Spearman, Ben Leffler, Zohaib "Zo" Qadri, and Tom Wald. Greg Smith, an executive at an insurance and risk management firm without a political track record, is somewhere in between. Suzanne "Zena" Mitchell is a late entry to the race, filing Monday afternoon.

All of these candidates raised decent amounts of money as of the July 15 report (the next campaign finance filing is in October), so D9 is almost surely headed for a run-off, mostly likely between Guerrero and whichever of the four urban musketeers makes the best case to central-city voters. Part of that case has to be that they have enough staying power to close strong against Guerrero in a low-turnout December run-off. Leffler, who was O.G. urbanist Chris Riley's policy aide, has raised the most cash of the four; Spearman and Wald have more connections from their years as community advocates; and Qadri has generated the most grassroots energy so far, including on campus (he's the youngest of the quartet). — Austin Sanders



I-r: Ben Leffler, Joah Spearman, Tom Wald, Zohaib "Zo" Qadri, Linda Guerrero

COURTESY OF THE CANDIDATES' CAMPAIGNS

A Southwest State of Mind

Homelessness, mobility top D5/D8 issues

City Council Districts 5 and 8 begin just across the lake from City Hall, on opposite sides of Barton Creek; from there, D5 stretches down through the 04 and then sweeps the southern edge of town from Sunset Valley to Manchaca to I-35, while D8 heads to and across the Hays County line. They include some of Austin's most vulnerable areas to flooding and wildfire, but also major tech employers and industrial parks; they're riddled with transit and health care deserts, but also contain a lot of important corridors. As 10-1 original Ann Kitchen retires in D5, a crowd has emerged for her open seat, while D8 incumbent Paige Ellis again faces conservatives who consider this seat one of theirs by right, so to speak.

Ken Craig, Kitchen's senior policy advisor for almost her entire tenure, has much direct Council experience, having worked with his boss to pass the Housing-Focused Encampment Assistance Link (HEAL) initiative to place unsheltered Austinites in temporary housing while clearing unsafe encampments, and a new 911 triage process that offers mental health crisis care as an option, a major victory for local justice reformers. He wants to continue that work along with securing flood mitigation around Williamson and Onion Creeks and transit options south of Slaughter Lane, as well as to "stand strong against actions by Greg Abbott or the Supreme Court" that target marginalized Austinites.

Ryan Alter (no relation to Mayor Pro Tem Alison Alter), an attorney and aide to then-state Sen. Kirk Watson from 2015 to 2020, calls for streamlining site planning and reducing fees to incentivize multifamily housing on larger lots in South Austin, targeting the elusive "missing middle" housing. He says Kitchen's HEAL initiative is too small in scale (her just-passed budget rider contemplates serving 200 people this upcoming fiscal year) and wants to better coordinate the 50-plus existing service providers in Austin to tailor solutions to the specific circumstances of each person without housing.

On the other hand, attorney/filmmaker/entrepreneur Aaron Webman, who claims "zero desire to run for office beyond this election," says Austin is repeating the wrongs of San Francisco and Los Angeles in its homelessness policies; he favors a "shelter first" approach, rather than the Housing First model the city is trying to follow. Bill Welch,

an Air Force veteran and businessman, wants to bring a "voice of reason" to Council, to advocate for more police funding, further enforcement of the camping ban, and more housing in transit corridors. Stephanie Bazan, a communications officer for a law firm who has worked with the Hispanic Impact Fund, wants improved accessibility in civic engagement and prioritizes education and families.

In mid-July, Alter had \$49,000 on hand, Bazan \$50,500, Craig \$14,000, and Welch \$11,000. Webman reported more than anyone (\$104,000 on hand), but that includes a \$50,000 contribution to himself that should have been reported as a personal loan.

Over in D8, Ellis laid down a marker in July with a quite impressive report of over \$100,000 on hand. Richard Smith, a patent attorney, former judge, and member of the Oak Hill Association of Neighborhoods (OHAN), reported \$41,000 on hand last month to emerge as Ellis' chief competitor; he's running to turn around Austin's "public safety crisis, an inability to humanely and effectively address homelessness, and fiscal mismanagement/affordability issues." He wants to reduce property taxes, maintain "full staffing" of public safety departments, and conduct an independent audit of Council expenditures – all old favorites of would-be GOP council members. Yet he also mentions a lack of safe and abundant mobility as an issue in the southwest. Ellis has owned that space on Council, leading on initiatives to reduce traffic fatalities, create Living Streets (the successor to COVID's Healthy Streets), and champion the 2020 mobility bond that passed alongside Project Connect, a \$460 million investment in "safe routes to school, urban trails, and bike lanes," she says. A priority for the incumbent is redeveloping the Y at Oak Hill, where "there's an opportunity to create a more connected community, [with] access to grocery stores, an ACC campus, and jobs." Ellis says such unfinished business has compelled her to run again: "There's just too much happening right now to stop." There are two other candidates on the ballot: Neither Antonio Ross nor Kimberly Hawkins has reported any fundraising; Ross has voted exactly once in Travis County (he's 50), two years ago, according to the Austin Bulldog.

– Lina Fisher

MORE ON P.22

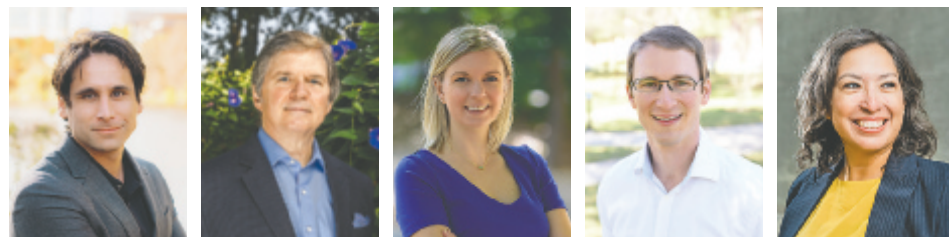

l-r: Aaron Webman, Ken Craig, Paige Ellis, Ryan Alter, Stephanie Bazan

COURTESY OF THE CANDIDATES' CAMPAIGNS



BACK TO SCHOOL



Luxe Refill August Sale Online & In-store:

- Upcycled Notebooks
- ALL To-Go Containers
- Water Bottles
- Compostable Binders
- Compostable Zip Bags
- Silicone Zip Bags
- Colored Pencils
- Rareform Lunch Bags
- Vegan Beeswax Wrap
- Compostable Wraps
- Togo Cutlery



5501 North Lamar, Ste. B110 | luxerefill.com

fresh books!

hot coffee!

great gifts!

Get 10% off your next in-store purchase
when you show this ad at checkout

*not valid on gift cards or services such as shipping

Book People

A Community Bound by Books.

Wanted: Heroes. Salary: Nothing

Solid candidates find their way to AISD Board races

Five of nine seats on the Austin ISD Board of Trustees are up Nov. 8, with only two incumbents seeking reelection; the new board's main order of business will be to conduct a promised national search for yet another new superintendent (Anthony Mays has taken the reins in the interim). If trustees got paid for what is easily a 20-hour-per-week job, we might have more candidates, but at least we have some good ones.

Current Board Prez Geronimo Rodriguez left AISD watchers in suspense as he waited to file for reelection until last week. His **District 6** covers South-Central Austin, running along and just west of I-35, including the district's central offices. Rodriguez was first appointed to the board to replace Paul Saldaña in 2017, reelected without opposition in 2018, and then named president by his colleagues later that year, 12 hours after then-President Kendall Pace was forced out over revealed texts that disparaged local activists as "poverty pimps." Rodriguez has often acted as a peacemaking middleman, although crises such as 2019's school closures escalated quickly beyond his reach. Challenger Andrew Gonzales, a former AISD teacher, seeks to address the school-to-prison pipeline, overly stressful testing, teacher pay,



and "attacks on public health and teaching historical truth in our schools."

The other incumbent, Arati Singh in **At-Large Position 9** – an expensive race that covers the entire district – faces two opponents, pediatrician Tim Porter and interior designer Heather Toolin, neither with a campaign website as of press time. Singh, who lives in Southwest Austin, is an education consultant and former teacher elected in 2018; she's been vocal about improving equitable outcomes in the district and creating metrics to assess the success of equity efforts.

The open **District 1** (Northeast Austin) race, in the AISD Board's traditionally Black seat, sees LaTisha Anderson retiring after one term. Former *Statesman* reporter/editorialist and district communications chief Roxanne Evans, a leader in Austin education politics and policy for decades (including as a tri-chair of the district's powerful Facilities and Bond Planning Advisory Committee, or FABPAC) faces Candace Hunter, who's taught in AISD, Manor ISD, and at Austin Community College and currently runs Teacher Boot Camp, which coaches educators.

Likewise, the **District 4** (Northwest Austin) seat is being vacated by Kristin Ashy after one



l-r: Arati Singh, Candace Hunter, David Kauffman, Geronimo Rodriguez, Roxanne Evans

COURTESY OF THE CANDIDATES' CAMPAIGNS / AISD HEADQUARTERS PHOTO BY JANA BIRCHUM

term and features two members of noted political families, both of whom filed late and don't yet have websites. Kathryn Whitley Chu, the wife of Justice of the Peace Nick Chu and mother of an infant daughter, is a talented-and-gifted educator, formerly at Wells Branch Elementary. Clint Small, a builder, former member of Austin's parks board and Planning Commission, and onetime owner of Clint Small Phillips 66 on Northland Drive (a Best of

Austin winner in 2002), is a grandson of the namesake of AISD's Clint Small Middle School.

In **District 7**, the sprawling southwest district, David Kauffman is running unopposed to succeed Yasmin Wagner. Kauffman worked in AISD for 17 years, including 10 years as principal of Perez Elementary (which opened in 2006), and as AISD's director of multilingual education. He says he'll focus on equity.

– Maggie Q. Thompson

Storming the Castle

Wingnut crusaders want all of RRISSD



Conservative PAC Round Rock One Family endorses these rightwing candidates

COURTESY ROUND ROCK ONE FAMILY PAC

"We've faced a lot of difficulty with our board," said Round Rock ISD Trustee Tiffanie Harrison, using heroic levels of understatement. "There's a lot of misinformation, there's outright lies, and the difficult part is that I think that's part of the strategy: to create such a disruption that people divest from public education."

Harrison occupies one of seven positions on the RRISSD Board, five of which are on the ballot this November. The two positions that aren't up for election are held by Mary Bone and Danielle Weston, the trustees that Harrison – and everyone else paying attention – says have helped instigate the chaos that has swamped the board in the last two years.

That chaos includes screaming and arrests at board meetings that routinely last into the early hours of the night, walkouts and lawsuits from Bone and Weston targeting their fellow board members, and demonstrations on school grounds by armed protesters from outside the city waving Confederate flags. To put it plainly, Harrison and her colleagues are facing the same ugliness that is being fomented by white Christian nationalists at school boards across the country. They've received death threats, and Harrison reports that in the last week she and two others have received packages in the mail containing used tampons. She believes the packages were sent by her opponents.

"These are used menstrual products with real human blood – so, a biohazard – saying, 'A gift from Tiff,'" Harrison said. "I wish I was kidding. I cannot tell you the amount of time I've had to spend on

the phone with the police and FBI ... but these are the kind of people we're dealing with."

Now, five allies of Bone and Weston, calling themselves the "One Family" candidates, are running for the open positions on the RRISSD Board. They are:

- John Keagy for Place 1 (facing Dr. Kevin Johnson Sr., appointed to the board to replace Dr. Jun Xiao when he resigned earlier this year);
- Orlando Salinas in Place 3 (running against RRISSD Board President Amber Feller; Harrison is the VP);
- Jill Farris in Place 4 (running against incumbent Cory Vessa);
- Christie Slape in Place 5 (taking on board secretary Amy Weir);
- Don Zimmerman in Place 6 (running to unseat Harrison).

Alicia Markum, Linda Avila, Joshua Billingsley, Stefan Bryant, and Maryam Zafar are also running, but the real contest is between the One Family slate and the incumbents.

Zimmerman is a perennial candidate who in 2014 hit pay dirt and served two years on the Austin City Council. He has chosen to run against Harrison, who is Black, with the slogan, "Let's return the classroom to ABCs and 1-2-3s, not CRTs and LGBTs." Harrison said she's not overly worried about Zimmerman's challenge: "My opponent is so very extreme, and openly so, that I hope voters are paying attention," she said. "But we have five seats up and that means voters need to be paying attention to every single race."

– Brant Bingamon

AISD's Largest Bond Ever to Fix Infrastructure; ACC's Adds Campuses

Austin ISD has put forth its largest bond package in history for consideration on November 8 – \$2.44 billion worth of equity-focused critical infrastructure improvements that will require a 1-cent property tax increase to fund it. The bond includes: 1) Proposition A – \$2.3 billion for campus improvements, including the full modernization of five middle schools, with \$157 million for Burnet Middle and \$251.5 million for Travis Early College High School; \$10 million toward safety improvements like upgraded locks and security fences, and \$25.7 million for bus upgrades; 2) Proposition B – \$75.5 million for technology upgrades and equipment; and 3) Proposition C – \$47.4 million for stadium upgrades. Meanwhile, Austin Community College trustees also approved a \$770 million bond for the November ballot. If voters approve it, the funds will expand training for high-demand fields such as health care, advanced manufacturing, and IT at 11 existing campuses, while adding two new campuses in Southeast and Southwest Travis County. – Lina Fisher

Back on the Ballot: Housing for Poor People

Austin voters will be asked to consider a \$350 million housing bond as Proposition A on the Nov. 8 ballot. With funds from the \$250 million package approved in 2018 (and earlier ones in 2006 and 2012) nearly exhausted, a new round of bond dollars will allow the city to continue to subsidize income-restricted housing – which is increasingly difficult to finance privately, as land values and labor-and-materials costs in Austin continue to spiral up – through its Austin Housing Finance Corporation. The funds can also be used to acquire land, bolstering the city's nascent community land trust program, or to pay for home repairs for owners facing displacement. If voters approve the bond, the owner of a median-value home in Austin (\$358,400) would pay an extra \$46.59 in property taxes on their next bill. – Austin Sanders

Not on the Ballot: Police Oversight

Austin's criminal justice reform groups, organized as part of the larger left-leaning political action committee Equity Action, had hoped to place their citizen initiative to beef up Austin police oversight on the high-turnout Nov. 8 ballot, alongside a mayor's race, for maximum exposure. But they brought in their more-than-enough signatures (about 32,000, says Equity Action) with not much time to spare, and the City Clerk's Office has notified Council that it would not have enough time to validate the petition in time for Council to authorize the election this week. Instead, the groups backing the Austin Police Oversight Act are pressuring Council to adopt the ordinance as is, without sending it to voters, which is always an option when initiatives are submitted. This seems unlikely. Down in San Marcos, some of the same groups and their Hays County allies helped craft a marijuana decriminalization proposal that will be on the ballot there. – Austin Sanders

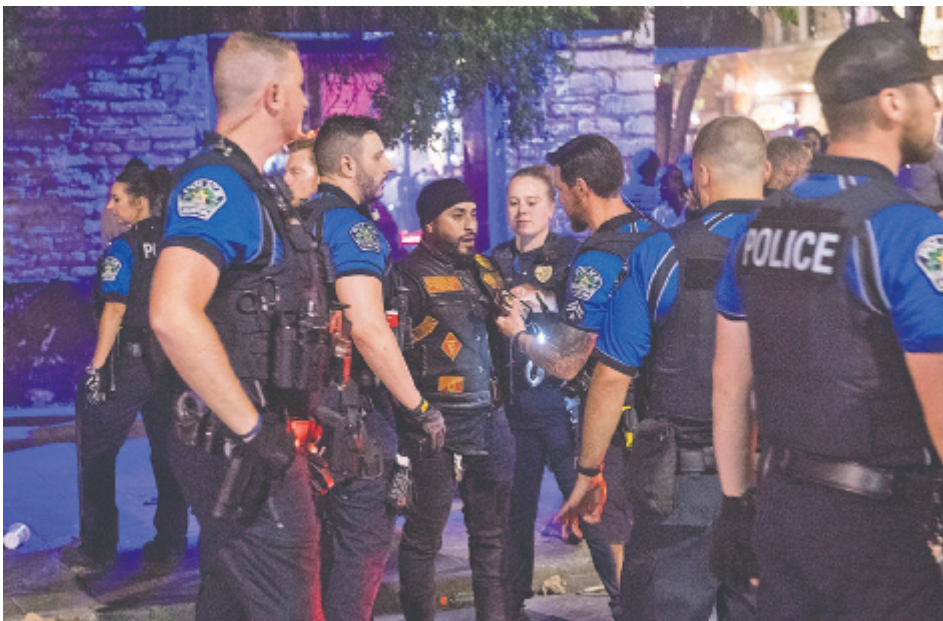

APD officers make an arrest on Sixth Street on June 11, 2022

JOHN ANDERSON

PERIPHERAL NEUROPATHY SOLUTION

Austin, TX — Are you experiencing numbness, tingling, or pain in the hands and feet? Are you finding it difficult to balance and have a fear of falling? It's possible you have Peripheral Neuropathy which is caused by nerve damage.



Figure 2: Just as plant's roots grow when watered, the blood vessels will grow back around the nerves.

Peripheral Neuropathy is a chronic degenerative disease. If left untreated, the condition will continue to progress. Over time our nerves experience a loss of blood supply from constriction which leads to degeneration. A damaged nerve will start to send abnormal signals to the brain which will bring sensations of burning, tingling, and intense pain. Further, more serious progression of nerve damage will present as numbness. This leads to a high risk of falling, dropping things, and loss of independence.

Now for some good news. There is a facility right here in Austin that offers hope for relief without having to take drugs with harmful side effects.

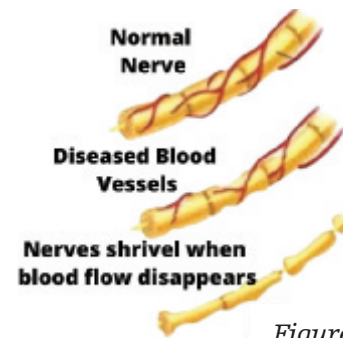

Figure 1

Figure 1 provides a visual of what happens when the blood vessels that surround the nerve become constricted and shrivel up. This prevents the nerve from getting the blood supply and nutrients it needs to survive. As these nerves begin to degenerate it leads to Peripheral Neuropathy.

Three Factors to Effectively Treat Neuropathy:

- 1) Find the Underlying Cause
- 2) Evaluate the amount of nerve damage
- 3) Determine the amount of treatment required

Goals of Treatment:

- 1) Increase Blood Flow
- 2) Stimulate Nerve Fibers
- 3) Decrease Pain

Our treatments return blood flow and nutrients to the affected area to stimulate the growth and repair of blood vessels and peripheral nerves.

Dr. Lucas Brown, DAOM at Rosedale Acupuncture & Wellness, will perform a Neuropathy Severity Examination to determine the extent of the nerve damage, which consists of detailed sensory and vascular testing along with an analysis of neurological findings.

We will be offering this \$40 examination from now until Wednesday, August 31st. To ensure quality of care Dr. Brown will only accept 10 new Peripheral Neuropathy patients a month.

Call 512-623-1996 to find out if you are a candidate for our program and get your life back.

Stop Hunting! Start Living!

CALL TODAY 512-623-1996
RosedaleAcuWell.com

1403 W. 45th St.
Austin, TX 78756

CALENDAR

AUGUST 25 > SEPTEMBER 1



25 > THURSDAY

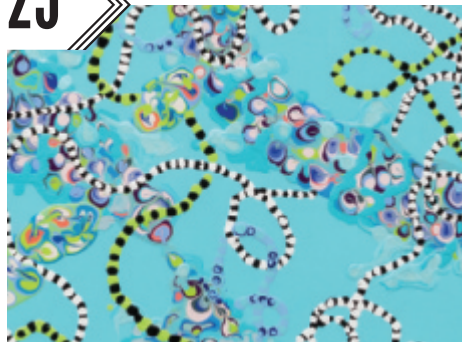

"ENTANGLED"
Camiba Gallery, 6-8:30pm

Collected and respected for her experimental approach to painting, Charlotte Smith is well-established as royalty in Texas contemporary abstract art; this is an exhibition of her most recent paintings.

See more arts events on p.28.

26 > FRIDAY



CLARA BLACKSTONE
Fallout Theater, 8pm

Chain-smoking trans woman comic-about-town Clara Blackstone headlines the Fallout, bringing along opening sets from her funniest friends: Angelina Martin, Elizabeth Spears, Jose Da'Hype, and Andrew Wagner.

See more LGBTQIA events on p.32.

27 > SATURDAY



BAT FEST
Congress Avenue Bridge, 4pm-12mid

Celebrate Bat City's famous million-plus Mexican free-tailed bats at a fest with music from about a dozen artists including the Toadies, Chamillionaire, and Bun B, plus a variety of vendors, children's activities, and more.

See more community events on p.32.

28 > SUNDAY



FREE DAY OF DANCE
Ballet Austin, noon-5pm

Alvin Ailey wrote, "Dance is for everybody. I believe that the dance came from the people and that it should always be delivered back to the people." So Ballet Austin brings it with classes ranging from ballet to West African dance, for a great way to end the summer.

See more arts events on p.28.

29 > MONDAY



ROBERT EARL KEEN
3ten ACL Live

The road may go on forever, but the party is coming to an end. Robert Earl Keen, acclaimed Texas songsmith and influential figure in Americana music, is closing the curtains on his 41-year-long touring career. Thankfully, he's not hanging it up for good without one more party in Austin.

See more music recommendations on p.54.

30 > TUESDAY



FUNNIEST PERSON IN AUSTIN
Cap City Comedy Club, 8pm

With the return of Cap City comes the return of its signature annual event, in which local comics (or, in some cases, the merely aspirationally funny) take the stage night after night, battling it out with stand-up sets to see who will eventually be crowned this year's Funniest Person in Austin.

See more arts events on p.28.

31 > WEDNESDAY

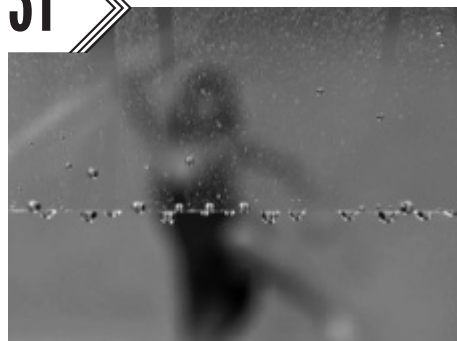

GENTLE OUR DRIFTLESS CARAVAN
Rain Lily Farm, 8:30pm

En Route Productions present this original sensory experience of movement, dance, and sound in an environment built in nature. Choreographed by BLIPSWITCH and Alexa Capareda, this reverie contemplates bereavement, lassitude, and water - a poignant end to a summer of relentless heat and years of loss.

See more arts events on p.28.

1 > THURSDAY

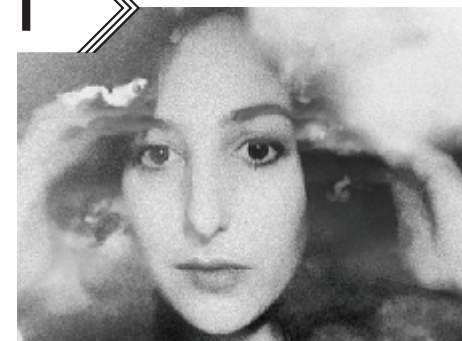

MARISSA NADLER
The Ballroom

As Nadler's music progresses further past its spare, acoustical roots, her live shows become increasingly valuable. A chance to hear one of indie's ghostliest artists at her most entrancingly spectral.

See more music recommendations on p.54.

AUSTINCHRONICLE.COM/EVENTS

SUBMIT!

For FAQs about submitting a listing, contact info, deadlines, and an online submission form, go to austinchronicle.com/submit.

the
**uncommon
FLEA**

SUNDAY • AUGUST 28

at
**uncommon
OBJECTS**



1602 FORTVIEW • AUSTIN • TEXAS • 78704

Shepherd's Parallelograms!

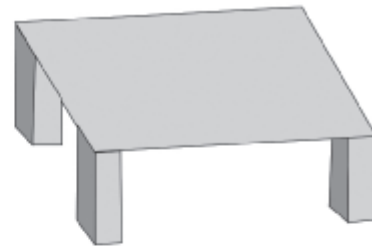

These two table tops
are identical!

Believe us or cut
them out and see for
yourself.

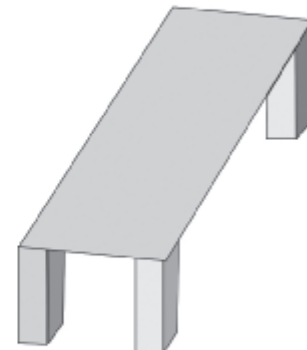

From the collection of optical illusions at cut-the-knot.org

**Math
Happens**

Scan the QR code for more.
Designed by Lauren Siegel at MathHappens Foundation.
For more information, visit www.mathhappens.org
or email us at info@mathhappens.org.



LEARN TO RIDE A DIRT BIKE

AUSTIN, TEXAS

- BIKE/GEAR RENTALS
- PRIVATE SESSIONS
- GROUP CLASSES
- MULTIDAY CAMPS
- ALL AGES AND SKILLS

713-377-0414

LEARN2RIDEATX.COM



...AND YOU WILL KNOW US BY THE **TRAIL OF DEAD** LIVE SATURDAY SEPTEMBER 3RD

WITH SPECIAL GUESTS
**AMERICAN SHARKS
MONTAZ**

COMPLIMENTARY
BEVERAGES.

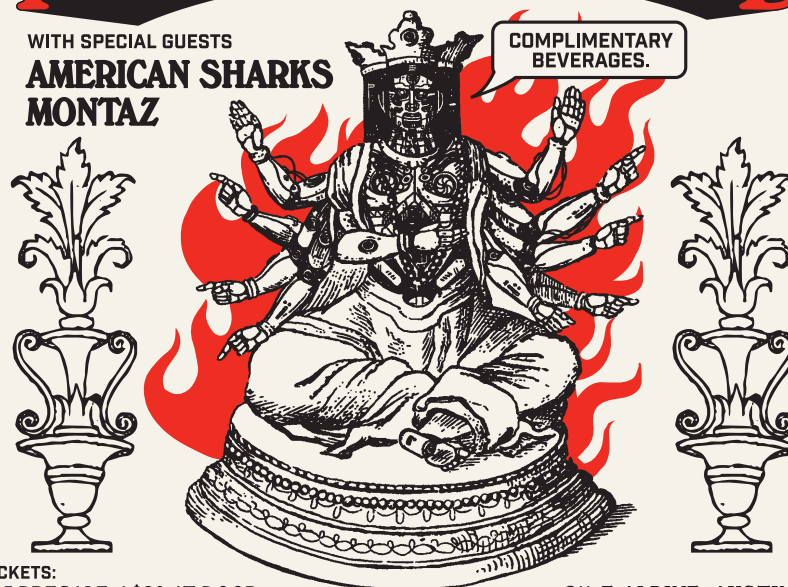

TICKETS:
\$15 PRESALE / \$20 AT DOOR
TICKETS AVAILABLE AT FSGPRINTS.COM

211 E ALPINE, AUSTIN, TX
ALL AGES - DOORS 6PM

Culture

Elizabeth Purchell, in the Flesh

The film historian and archivist is leading the reappraisal of porn and erotica as a vital chapter in the history of queer liberation **BY JAMES SCOTT**

Like all the best parts of queer history, not everyone knows about Elizabeth Purchell. Those who do know the film historian often pick that knowledge up through her work with Austin Film Society as the Queer Cinema: Lost & Found series programmer. Others may know her through her 2019 documentary film, *Ask Any Buddy*, made up of stitched-together archival clips of gay male pornography, or its accompanying Instagram feed and podcast. She has been a staunch advocate of the less-loved elements of queer film's lineage – the porn, the weird, the wild – since a 2016 screening of a 1972 gay erotic film, *Bijou*, in Tampa, Florida, with director Wakefield Poole in attendance. Purchell recalled, “Seeing that specific film just made me go, ‘Well, if this exists, what else is there?’ ... I’d always write this stuff off as, ‘It’s just old porn. Who cares about that, there’s porn everywhere.’ But finally starting to see these films as art and cinema really flipped a switch in my brain.”

In programming Queer Cinema: Lost & Found, Purchell wanted to provide an opening to budding LGBTQ cinephiles. She described her programming as a cross between two other AFS series, Essential Cinema and Lates: hitting familiar canonical film beats as well as deeper cuts. “Every single screening, it’s been a completely different crowd every time,” Purchell said. “When we showed *Cruising*, the screening sold out, [and] people were there in full [leather] gear. It was wonderful. And then when we showed *Kamikaze Hearts*, which is this lesbian movie about the porn industry, it was nothing but young dykes. As I was walking out of the theatre, I heard someone say, ‘This is the hottest crowd I’ve ever seen at this

theatre.’” Next on the schedule is what Purchell described as the perfect end-of-summer flick: *Wigstock: The Movie*. Not only will director Barry Shils be in attendance for a post-film Q&A, but folks will be treated to a big, fun, drag festival documentary just a week after Pride. “I love more serious dramatic things but I also just like dumb fun,” she said, “and I think *Wigstock* is about as dumb fun as you can get.”

As a self-identified curious filmgoer, Purchell’s urge to know more about the media she likes has been in her from a young age. While growing up in Florida during the less-accepting early Nineties and early Aughts, she consumed all of the

Criterion Collection from her local library as well as all the sci-fi and horror genre films available. Movies were a gateway to LGBTQ life, and that lens influenced her later in life. “My knowledge of queer people or trans people didn’t really extend further than what I saw on TV, in movies, or on tabloid,” she said, citing *Rolling Stone*’s outing of Lana Wachowski as a deep-rooted memory that came up during her gender transition last year.

Her interest in queer adult cinema began at that *Bijou* screening, but over the years she’s amassed a wide knowledge of gay male pornography from the Sixties, Seventies, and Eighties. Other people’s lack of respect for what those films represented in the queer cinematic lineage bothers Purchell. Flattening the historical scope to only see films from the mid- to late Eighties, or in the New Queer Cinema oeuvre like Todd Haynes’ or Gregg Araki’s work, does a disservice to the myriad erotic films that formed those later queer works’ foundation. Purchell pointed to films like

“I’d always write this stuff off as ‘It’s just old porn. Who cares about that, there’s porn everywhere.’”

ELIZABETH PURCHELL



Elizabeth Purchell, in front of Steve Scott’s *Gemini* (1977)

JANA BIRCHUM

Fred Halsted’s *L.A. Plays Itself*, Radley Metzger’s *Score*, or director Arthur J. Bressan Jr.’s pornographic filmography as underappreciated cornerstones in the depiction of gay life on screen. “These gay adult films did the groundwork,” Purchell said. “In these films, you see some of the very first gay coming out stories on film, you see the first gay romances. There are gay horror films, there’s gay war films – gay Westerns, gay comedies, movies about gay marriage and gay divorce.”

Interacting with these works of pornographic art for as long as she has, Purchell admitted her relationship to the materials did shift once she began transitioning. “This entire time, I’ve been looking at these films simply as cinema, you know. I don’t really get turned on by them,” she said. After coming out as a trans woman and realizing her attraction to other women, the distance between herself and the gay male sex on screen became understandable. Replacing any sense of titillation was an appreciation for the incredible craft behind many of these older gay pornographic films, which Purchell reasoned is why she’s been a successful historian of the genre. “There

were [directors] who really did see making these films as being a political act,” she said, adding that most directors like Arthur J. Bressan Jr. found sex to be a source of gay liberation. “[Liberation] wasn’t just the right to get married or join the Army; it was to have sex and not get arrested or face legal prosecution for it.”

Purchell originally came to Austin for its film scene but current conservative attacks have made Texas a hard place to stay in. “It’s been very scary and very hard for me to continue to want to live here,” she admitted. “I’ve been followed around H-E-B. I’ve been called a faggot for the first time on the street. Been gawked at a lot.” Despite a growing sense of fear that’s driving her away from Texas, Purchell said she still treasures her current work with AFS. “I’m so proud and honored ... to create this little space where people can come and see themselves on screen,” she said, “to see queer movies as an escape or as a galvanizing force to do something, to take action.” ■

Queer Cinema: Lost & Found presents *Wigstock: The Movie*, Fri., Aug. 26, and Wed., Aug 31, 7pm at AFS Cinema, 6406 N. I-35 #3100. austinfilm.org.

ARTS EVENTS AC

THEATRE

OPENING

JIGGLEWATTS BURLESQUE REVUE And here's the latest installment of the Jigglewatts' **Live Band Burlesque** series, featuring a dazzling burlesque show with music from the **Foxtones**. *Thu., Aug. 25, 8pm. The Ballroom, 2906 Fruthe, 908/887-1795. \$20-140. thejigglewattsburlesque.com.*

FAT BOTTOM CABARET: FAIRY TALES & FANTASIES Your **Midnight Menagerie** cast of **Chola Magnolia, Lady Lola LeStrange, Jasper St. James, Azucar**, and special guests **Gothess Jasmine** and **Kitty Von Quim** encourage you to let your imagination run wild at this plus-sized burlesque spectacular. *Sat., Aug. 27, 7pm. Stateside at the Paramount, 719 Congress, 512/472-5470. \$20-45. instagram.com/fatbottomcabaret.*

VAVA DOOM: METALESQUE A tribute to the dark, evil, mystical, and metal among us, this new Unholy Sabbath series features burlesque, sideshows, drag, and more, all set to metal music subgenres. *Sun., Aug. 28, 8-10pm. Valhalla, 710 Red River, 512/476-0997. \$15-100. fb.com/valhallatavern.*

CLOSING

✪ **ANNA IN THE TROPICS** Ground Floor Theatre presents **Nilo Cruz's** compelling play, winner of the **2003 Pulitzer Prize for Drama**, about a family of cigar makers in Ybor City, Fla., whose loves and lives are played out against the backdrop of Depression-era America. Starring **Ben Bazán, David Segura, Tonie Knight, Cherry Mendoza, Briana Garcia, Michael Galvan**, and **Victor Santos** - directed by **Carl Gonzales**. Bonus: paintings by **Victoria Marquez** in the lobby gallery. *Through Aug. 27. Thu.-Sat., 8pm. Ground Floor Theatre, 979 Springdale #122, 512/840-1804. \$25. groundfloortheatre.org.*

HEDWIG AND THE ANGRY INCH John Cameron Mitchell and **Stephen Trask's** kickass gender-bending musical is a glamorous spectacle of life and longing, here starring **Buddy Novak** as Hedwig and **Susannah Crowell** as Yitzhak. Directed by **Jeff Hinkle**, with musical direction by **Audrey Barrett**, for the **Stage Austin**. *Through Aug. 27. Thu.-Sat., 8pm. Dougherty Arts Center, 1110 Barton Springs Rd., 512/974-4000. \$20-25. thestageaustin.com.*

THE SOUND OF MADE UP MUSIC This is a **completely improvised musical** inspired by **Rodgers & Hammerstein** and other classic musical-making artists. You'll see characters like Maria and the Baron from *The Sound of Music*; or Billy and Julie from *Carousel*; or Laurey, Curly, and Jud from *Oklahoma!*; or who knows who else will come singing and a-dancing out of the woodwork? Watch as the Hideout's skilled improvisers unleash the tropes and tones, the styles and star power of legends. *Through Aug. 27. Saturdays, 8pm. Hideout Theatre & Coffeeshouse, 617 Congress, 512/476-1313. \$12-18. hideouttheatre.com.*

PET DICK: THE FOUND TAPES From theatre powerhouse **Jarrott Productions** comes this **Carlo Lorenzo Garcia**-scripted **audio performance** about how "in 1969, in rural Lincoln, Illinois, a private investigator named Jerry Labinowicz documented on micro-cassette tapes his investigations into a series of unexplained pet deaths over the course of 20 years." Available through *Aug. 31. \$15-18. jarrottproductions.com.*

ONGOING

JUDITH In **Katie Bender's** "delightfully off-kilter" new play, Judith, dressed as a man, moves to London to stand trial in her absent brother's place, and - when the trial goes badly - begins to write plays to please the Queen and restore her brother's good name. This **solo show about ambition, artistry, love, and Shakespeare** features **Taylor Flanagan** as Judith and is directed by **Madge Darlington**. *Through Sept. 3. Thu.-Sat., 8pm. Hyde Park Theatre, 511 W. 43rd, 512/479-7529. \$12-26. hydeparktheatre.org.*

COMEDY

THE HIDEOUT The diverse lineup of sometimes hilarious, always surprising improv shows has returned, with **Pgraph** and **Maestro** and more, for the most unexpected delights of in-person entertainment. For instance, this weekend: **Glitter Witch**, featuring the improv magic created by **Regina Soto, Lisa Jackson**, and **Jessica Arjet**. See the website for details. *Hideout Theatre & Coffeeshouse, 617 Congress, 512/476-1313. hideouttheatre.com.*

COLDTOWNE "Set your dial to CTTV for at-home entertainment on ColdTowne's Twitch channel, featuring experimental improv, live podcasts, scripted readings, guest characters, and more." And they've got in-person shows popping up around town, too - Violet Crown Clubhouse, anyone? - so see that website for details. *coldtownetheatre.com.*

ESTHER'S FOLLIES *Esther's Follies* - Austin's **not-so-secret weapon in the fight against ennui** - the **comedy gem that still dazzles this growing urban hub** - returns to the **weekly live and in-person** stage of their club on Dirty Sixth, the whole troupe bringing back **old favorites** and debuting a **new program of hilarity** with topical, ripped-from-the-headlines **sketches** and **musical numbers**. Also: the **mind-boggling illusions** presented by magician **Ray Anderson**. *Thu., 7pm; Fri.-Sat., 7 & 9pm. Esther's Follies, 525 E. Sixth, 512/320-0198. \$30-40. esthersfollies.com.*

FALLOUT COMEDY This hotbed of local performance is carrying on even more than usual, with an eclectic mix of **live, mind-rocking comedy** from some of Austin's best, all week long. Pro tip: The **Sure Thing** showcase on Friday night is, as ever, a don't-miss event. And, srsly, who would ever disagree with the sentiment of Monday night's **Fuck This Week** show? Check the website for details. *Fallout Theater, 616 Lavaca, 616/676-7209. falloutcomedy.com.*

THE CREEK AND THE CAVE This snazzy spot for local and national stand-up acts has shows almost every night of the week. But you knew that already, right? **Let's Get Quizzical, Out in Tech**, the **Pendejo Time** podcast, **Your Mom's Favorite Comedian** - ah, the onslaught of levity is nigh on relentless. See website for details. *The Creek and the Cave, 611 E. Seventh, 737/222-0852. creekandcave.com.*

CAP CITY COMEDY CLUB: READY FOR LAUGHS That's right: **Cap City Comedy Club**, the cornerstone of Austin's comedy scene for nearly four decades, has returned - at a new venue in the Domain - with an **ongoing showcase of the country's top comics** gracing the main stage each weekend. And top talents from the local scene featured in the Red Room - this week, **Mac Blake** (Aug. 25) and **Isabel Hagen** (Aug. 26-27). See website for details. *Cap City Comedy Club, 11506 Century Oaks Ste. B-100, 512/467-2333. \$30-40. capcitycomedy.com.*

EAST AUSTIN COMEDY CLUB Founded by comedians **Raza Jafri** and **Andre Ricks**, this club that operates out of Tiger Den on the Eastside is the **city's only BIPOC-owned comedy venue**. *Tiger Den, 1303 E. Fourth. eastaustincomedy.com.*

ALEX MOFFAT A breakout performer on *Saturday Night Live*, **Alex Moffat** most recently succeeded Jim Carrey as Joe Biden on the show. He's funnier than any president, though. Much, much funnier. *Fri.-Sat., Aug. 26-27, 7 & 9pm. The Creek and the Cave, 611 E. Seventh, 737/222-0852. \$25. creekandcave.com.*

CLARA BLACKSTONE Chain-smoking trans woman comic-about-town **Clara Blackstone** headlines the Fallout, bringing along opening sets from her funniest friends: **Angelina Martin, Elizabeth Spears, Jose Da'Hype**, and **Andrew Wagner**. *Fri., Aug. 26, 8pm. Fallout Theater, 616 Lavaca, 616/676-7209. \$20 (\$15 in advance). falloutcomedy.com.*

BUZZ MILL COMEDY This newest Buzz Mill (right there on Seventh) has a full slate of funny supercharging their sweet and welcoming lounge, night after night after night. Check their website, see what's on, and (serving suggestion) treat yourself to some mighty tasty noms while you're there. *Buzz Mill Eastside, 1209 E. Seventh. buzzmillcoffee.com.*

CONTINUED ON P.28

FORBIDDEN FRUIT

August is ANAL AMOR Month

TONS OF TOP NOTCH GEAR FOR YOUR REAR IS HERE!

Plugs, Beads, P-Spot Stim Toys, & More!

8/28 **All About Anal** w/Sexpert Jonny
info/enroll@forbiddenfruit.com

OPEN MON-SAT 12-7, SUN 12-6 • CURBSIDE PICKUP AVAILABLE



PHOTO BY RICARDO ACEVEDO



108 EAST NORTH LOOP BLVD. • 512-453-8090

Shop ONLINE AT: **FORBIDDENFRUIT.COM**

TEASIN' & PLEASIN' TUSHES SINCE 1981!

WATER DISTRICT NOTICE OF PUBLIC HEARING ON TAX RATE

The North Austin Municipal Utility District No. 1 will hold a public hearing on a proposed tax rate for the tax year 2022 on Wednesday, September 14, 2022 at 6:00 p.m. at the Rattan Creek Community Center, 7617 Elkhorn Mountain Trail, Austin, Texas 78729.

Your individual taxes may increase at a greater or lesser rate, or even decrease, depending on the tax rate that is adopted and on the change in the taxable value of your property in relation to the change in taxable value of all other property. The change in the taxable value of your property in relation to the change in taxable value of all other property determines the distribution of the tax burden among all property owners.

Visit [Texas.gov/PropertyTaxes](https://www.texas.gov/PropertyTaxes) to find a link to your local property tax database on which you can easily access information regarding your property taxes, including information about proposed tax rates and scheduled public hearings of each entity that taxes your property.

(Names of all board members and, if a vote was taken, an indication of how each voted on the proposed tax rate and an indication of any absences.)

FOR the proposal: Directors Conklin, Jones, Christiano, Roche-Green, and Beaulieu
AGAINST the proposal: None
PRESENT and not voting: None
ABSENT: None

The following table compares taxes on an average residence homestead in this taxing unit last year to taxes proposed on the average residence homestead this year.

	Last Year	This Year
Total tax rate (per \$100 of value)	\$0.2625/\$100 Adopted	\$0.2435/\$100 Proposed
Difference in rates per \$100 of value	(\$0.0190)/\$100	
Percentage increase/decrease in rates (+/-)	-7.24%	
Average appraised residence homestead value	\$370,632	\$526,293
General homestead exemptions available (excluding 65 years of age or older or disabled person's exemptions)	\$ _ _ _ _	\$ _ _ _ _
Average residence homestead taxable value	\$325,349	\$362,363
Tax on average residence homestead	\$854.04	\$882.35
Annual increase/decrease in taxes if proposed tax rate is adopted (+/-)	\$28.31	
and percentage of increase (+/-)	3.32%	

NOTICE OF VOTE ON TAX RATE

If the District adopts a combined debt service, operation and maintenance, and contract tax rate that would result in the taxes on the average residence homestead increasing by more than 3.5 percent, an election must be held to determine whether to approve the operation and maintenance tax rate under Section 49.23602, Water Code.

The 86th Texas Legislature modified the manner in which the voter-approval tax rate is calculated to limit the rate of growth of property taxes in the state.

Five Celebrations of Nature

Because you know we're all just a bunch of animals

BY WAYNE ALAN BRENNER

Never mind the differences between a beaver's dam and a human's residential subdivision, yes, but also disregard the similarities. Force a dichotomy: There are humans and their manufactured surroundings, and then there's all the rest of this big blue marvelous rock that we've been spinning on for millennia now. The environment. The wilderness. All the terrestrial flora and fauna that don't walk upright on two legs and buy nacho cheese Hot Pockets from the nearest gas station. That's what these five events are in support of – although quite a bit of humanity's in here, too.



Alejandra Regalado's *Sul* #5, part of Big Medium's 'Yo Trabajo con la Tierra' exhibition

BIG MEDIUM: "YO TRABAJO CON LA TIERRA / I WORK WITH THE EARTH"

This multimedia, multivalent, multifantastic exhibition features five women artists – Melissa Aguirre, Alexa Capareda, Paloma Mayorga, Virginia Lee Montgomery (VLM), and Alejandra Regalado – who explore movement and place in relation to landscape, geological bodies, and other nonhuman intelligences. Using their own bodies as medium, the artists share ecofeminist sensibilities through video, installation, sculpture, photography, and performance works. **Through Sept. 24. 916 Springdale Bldg. 2 #101, 512/939-6665. bigmedium.org**

EN ROUTE PRODUCTIONS: GENTLE OUR DRIFTLESS CARAVAN

An original sensory experience of movement, dance, and sound in an environment built in nature at the lovely Rain Lily Farm. Choreographed by BLIPSWITCH and Alexa Capareda, this reverie contemplates bereavement, lassitude, and water – a poignant end to a summer of relentless heat and years of loss. Set designer la Ensterä and technical director Cherya Esters transform the farm's grounds into a space for exploring these forces of nature, underscored with a soundscape by Henna Chou and Adam Hilton, and the whole spectacle is illuminated by Natalie George Productions. **Wed.-Sat., Aug. 31-Sept. 10, 8:30pm. Rain Lily Farm, 914 Shady, 512/636-4430. \$25. enrouteproductions.com**

DAVIS GALLERY: "TRAILHEADS AND TRANSMUTATIONS"

Natural beauty captured with consummate skill and passion by two longtime locals. Artist couple Felice House and Dana Younger present new works of painting and sculpture that study, observe, process, and transmute the wild spaces and creatures of Texas, their creations deeply resonant with those of painter Thomas Cole, father of the Hudson River School. Don't miss our interview with the artists, "Trailheads and Transmutations" at Davis Gallery Honors the Reparative Quality of Nature" (Daily Arts, Aug. 5), at austinchronicle.com/arts. **Through Sept. 3. 837 W. 12th, 512/477-4929. davisgalleryaustin.com**

THE VORTEX: NAKED AT MY AGE

Nature does include human nature – and little is more redolent of that nature than sexuality. Also, they don't call nudity "going au naturel" for nothing, n'est-ce pas? And here Charla Hathaway – Austin's own "Erotic Muse, Whore, and PhD sex educator" – takes it off for you in her one-woman show about sex work. Imagine "a grandma's surprising Sexual Renaissance, fraught with difficult and isolating choices, [that] leads to risk, lust and healing in the Oldest Profession." Hathaway, at 70, continues to expand the definition of sex, seducing you with stories from her 20-year pioneering career. **Fri.-Sat., Aug. 26-27, 8pm. 2307 Manor Rd., 512/478-5282. \$15-37. vortexrep.org**

ATX SCIREAD BOOK CLUB: ENTANGLED LIFE

BookPeople nonfiction guru Griffin and the Austin Texas Science Writers host a monthly book club (via Zoom) devoted to the best of science and nature writing. September's discussion focuses on *Entangled Life* by Merlin Sheldrake, a mycelial masterpiece about "how fungi make our worlds, change our minds, and shape our futures." Because no matter how well we're currently doing, there's always mushroom for improvement. **Sun., Sept. 4, 4pm. Virtual. Free. bookpeople.com**

COMEDY CONTINUED FROM P.27

FUNNIEST PERSON IN AUSTIN With the return of **Cap City Comedy Club** comes the return of Cap City's signature annual event, in which local comics (or, in some cases, the merely aspirationally funny) take the stage night after night, battling it out with stand-up sets, to see who will eventually be crowned this year's Funniest Person in Austin. Right now the **preliminary rounds** are underway, with the champion-packed night of finals set to rock this town on Wed., Sept. 21. *Prelims: Sun., Aug. 28; Tue.-Wed., Aug. 30-31; Tue., Sept. 6. All shows at 8pm. Cap City Comedy Club, 11506 Century Oaks Ste. B-100, 512/467-2333. \$10-18. capcitycomedy.com.*

DANCE

🌟 **THE BAREFOOT BALL** This is a **celebratory benefit ball** supporting **First Street Studio**, East Austin's home for the dance community. Enjoy an evening of free cocktails, live music, dance, community, and connection among local arts lovers. "All the glamour, without the shoes!" *Sat., Aug. 27, 7:30-10pm. First Street Studio, 2410 E. Cesar Chavez #202, 512/630-2351. \$20-30. firststreetstudioatx.com.*

BALLET AUSTIN: FREE DAY OF DANCE CLASSES You already know that you can **learn your way to physical grace** with a dance class at Ballet Austin, with ballet, barre, contemporary dance, hip-hop, tap, cardio dance fitness, Pilates, and more – all taught by professional instructors. And today, you can **try out a variety of those classes, for free!** See website for details. *Sun., Aug. 28, 1-5:45pm. balletaustin.org.*

AMERICAN INDIAN HERITAGE DAY: DANCING AND DRUMMING An evening public program celebrates the **traditional and contemporary arts of Texas' American Indian groups** – with dancing and drumming performances. *Thu., Sept. 1, 6pm. Bullock Texas State History Museum, 1800 Congress, 512/936-4629. Free with admission. thestoryoftexas.com.*

CLASSICAL MUSIC

🌟 **LOLA: LARDO WEeping** This is an original opera from award-winning composer **Peter Stopschinski**, based on an adaptation of **Terry Galloway** and **Donna Nudd's** one-woman play of the same name, centered on "reclusive genius **Dinah LaFarge**, a clever, agoraphobic, quite sexual woman of independent means who refuses to answer her door unarmed." Dinah is played by **Liz Cass**, with supporting performances by

Nicole Taylor, Page Stevens, Holt Skinner, Alexa Capareda, and Daniela Bennetti; pianist Stopschinski is abetted by **Phil Davidson** (violin) and **Barbara George** (cello). *Through Sept. 2. Thu.-Sat., 7pm; Sun., 3pm. Crashbox, 5305 Bolm #12. \$25. lolaustin.org.*

VISUAL ARTS

EVENTS

CATHEDRAL OPEN HOUSE Here's a **night of music, drinks, and art** that highlights Austin's top women artists, featuring abstract painter and designer **Molly Knobloch**. Bonus: live music from **Tearjerk** (8-9pm). *Fri., Aug. 26, 7-10pm. The Cathedral, 2403 E. 16th, 512/220-4108. \$15-25. thecathedralatx.com.*

SECRET WALLS: SUPPORT YOUR LOCAL ARTIST TOUR L.A.-based **Secret Walls** brings its inaugural Support Your Local Artist tour to Austin, where you'll watch artists go head-to-head in seeing who can transform white walls into the best murals in just 90 minutes. Featured locals include **Villararte, Fish, Cody Schibi, Andrew "APSE" Horner**, and more. *Fri., Aug. 26, 7pm. Come & Take It Live, 2015 E. Riverside. \$25. secretwalls.world.*

RAW PAW STUDIO TOUR Not only is this the opening party for a **new art show** by the indefatigable **Raw Paw** crew – **Kyle Carter, Chris Dock, Brittany Bernstrom, Lyle Lewis, Maryssa Chavez, Rory Blank**, and more – but there'll be music by **DJ Celly** (9-11pm); and the night's free beverages are provided by JuiceLand, St. Elmo Brewing, Tito's Vodka, and Blue Norther; and you'll be in the Yard, the Yard, that glorious goddamn Yard off St. Elmo. *Sat., Aug. 27, 6pm-12mid. Raw Paw, 506 E. St. Elmo Ste. A-3, 512/522-5872. Free. rawpaw.ink.*

JUSTIN FAVELA: REVOLOTEO Justin Favela's work examines the **intersection of American pop culture and the Latinx experience** via transforming ordinary spaces into "fantastical rooms filled with joyful color and texture." Here's the debut of his new mural at the St. Edward's University Fine Arts Gallery. *Thu., Sept. 1, 6-9pm. St. Edward's University, 3001 S. Congress, 512/448-8400. Free. stedwards.edu.*

OPENING

ACC ART GALLERIES: QUOTATIONS FROM DAILY LIFE This exhibition brings together the work of seven ACC Studio Art faculty members – **Jill Bedgood, Jonas Criscoe, Melanie Hickerson, Brian Johnson, Haydeé Victoria Suescum, David**

CONTINUED ON P.30

aGLIFF's PRISM 35 LGBTQ+ Film Festival

THIS WEEKEND at the Galaxy Theatres Austin | Virtual Encore Aug 29-Sept 5



Black As U R

Documentary Centerpiece • Fri, Aug 26 • 7pm

Writer/Director Micheal Rice's powerful documentary that dares to ask if Black Lives Matter when you're queer or trans.

Micheal Rice in Attendance



How to Tell A Secret

Sat, Aug 27 • 4:15pm

In Partnership with the Consulate General of Ireland, Austin

A film that explores the stigma that drives people living with HIV to withhold their status in contemporary Ireland.

Writers/Directors Shaun Dunne & Anna Rodgers in Attendance



Out in the Ring

Sat, Aug 27 • 7:15pm

The first documentary to chokeslam the hidden history of queer representation in wrestling.

Director Ry Levey, Wrestlers Iggy "Madness" Mendoza & Reiza Clarke in Attendance



A Run for More

Sun, Aug 28 • 12pm

One woman's journey to become the first openly elected transgender official in Texas.

Director Ray Whitehouse & Subject Frankie Gonzales-Wolfe in Attendance



Mama Bears

Sun, Aug 28 • 2:15pm

An exploration of two conservative, Christian mothers who have become fierce advocates for LGBTQ+ people.

Discussion with Sara Cunningham and local Mama Bears + free mom hugs after the film!



You Can Live Forever

Closing Night Film • Sun, Aug 28 • 7pm

A lesbian teen falls hard for a devout Jehovah's Witness girl.

Directors/Screenwriters Mark Slutsky & Sarah Watts in Attendance Includes Closing Night Party at St. Johns Studios



Over 85 Films • LIVE Filmmaker Discussions • Parties • Community
Full film lineup, badges and tickets at agliff.org/prism



Zach Theatre's *The Inheritance, Part 1*

PHOTO BY SUZANNE CORDEIRO

Review: Zach Theatre's *The Inheritance, Part 1*

A STUNNING PORTRAIT OF 21ST CENTURY GAY LIFE **BY BOB ABELMAN**

The Inheritance, Part 1 is stunning. It's the kind of stunning that leaves you so dazed by Matthew Lopez's superbly crafted script, director Dave Steakley's spell-binding production, and stellar performances that it requires a conscious act of determination to stop staring and start applauding at the end of the show.

Jonathan Larson's *Rent*, Tony Kushner's *Angels in America*, and Larry Kramer's *The Normal Heart* put a human face on and gave voice to the horrors of the 1980s/1990s AIDS epidemic. Lopez's 2020 Tony Award-winning portrait of gay life in the 21st century reflects a comparatively gilded era of uncloseted sexual identity, marriage equality, wider cultural representation, and treatable HIV. At issue – and the central premise of this play – is whether today's generation of young gay men understand or will forget what so much progress cost their forebears. “If we can't have a conversation about our past,” says sincere and intense Eric Glass (an absolutely riveting Christopher Joel Onken), the better half of the thirtysomething couple around which this play revolves, “then what will be our future?”

The Inheritance is that conversation. To help tell the story about the past and facilitate the telling of this generation's own story, Lopez infuses this work with magical realism, where fantastical elements seamlessly surface in the world of this play as if they were normative. Designers Josafath Reynoso (scenic) and Austin Brown (lighting) create a physical world composed of a bare, raised slate platform, which becomes different locations with the introduction of a rug, some furniture, and adjusted illumination. Ensemble members take on multiple roles without any effort at concealment, but mostly they form a Greek chorus of friends who pop in and out of scenes to offer commentary, hand-deliver props, and provide hard-bodied, Armani Exchange model eye candy (costume design by Aaron Kubacak). It's all magical realism. And good genes.

This creative convention allows for the casual materialization of long-dead author E.M. Forster (a wonderfully quirky, enigmatic Peter Frechette, who also plays Walter Poole, an older and unassuming friend of Eric's, with equal aplomb). Forster's 1910 novel *Howards End* provides the operational foundation for this play in which the author serves as a spirit guide for these modern-day New Yorkers – and, as a writer himself, humorously cleans up and rewrites some of Lopez's dialogue, particularly that spoken by Eric's roguish, self-centered, and less eloquent other half, Toby (an abundantly charming Jake Roberson). In Forster's presence, characters often refer to themselves in the third person, as if they were characters in a play, and narrate their own actions. In his absence, astute political and cultural debates weave their way through more amusing conversations about, say, the enduring value of camp as part of the gay sensibility.

All this adds up to a marvelously structured narrative that includes a few lengthy, engrossing monologues – like the one delivered by the young and economically privileged Adam (a mesmerizing Brenden Kyle MacDonald) about an evening of transcendent, dangerous sex in a gay bathhouse in Prague, presented with elation that morphs into haunting ambivalence. Also noteworthy and equally enthralling is Steakley's and movement director Cassie Abate's handling of an explicit and highly erotic onstage sexual encounter between Eric and Toby that consists of noncontact, metaphorical choreography.

It is easy to see why *The Inheritance, Part 1* was a Tony-worthy enterprise. But this production elevates it to something truly astonishing. ■

Zach Theatre's *The Inheritance, Part 1*
The Topfer, 1421 W. Riverside, 512/476-0541,
zachtheatre.org. Through Sept. 4
Time: 3 hrs., 15 mins.
***The Inheritance, Part 2* opens Sept. 14**

VISUAL ARTS CONTINUED FROM P.28

Thornberry, and Gary Webernick – who work in a range of media including painting, drawing, printmaking, assemblage art, and sculpture. Aug. 25-Oct. 27. ACC Highland, 6101 Highland Campus Dr. austinctc.edu.

☀️ **CAMIBA GALLERY: ENTANGLED** Collected and respected for her experimental approach to painting, **Charlotte Smith** is well-established as royalty in **Texas contemporary abstract art**; this is an exhibition of her most recent paintings. *Opening reception: Thu., Aug. 25, 6-8:30pm.* Camiba Gallery, 6448 Hwy. 290 E. Ste. A-102, 512/937-5921. camibagallery.com.

DR. SEUSS: CONCEPT DRAWINGS TOUR Ted Geisel (aka Dr. Seuss, of course) drew each page for every Dr. Seuss book published during his lifetime. For each final line drawing, he would create multiple concept drawings leading up to the final published image. See the man's creative process at work in this collection, currently on tour nationwide and now on display at Austin's own Ao5 Gallery. *Opening reception: Sat., Aug. 27, 6-9pm.* Ao5 Gallery, 10000 Research #118, 512/481-1111. Free. ao5gallery.com.

TOMBOY FEMME ART SHOW Paper-folding artist **Amanda Witucki** of the **Paper Committee** has a new exhibition at the Medici Roasting in Clarksville. Tell you what: You may have a different spot where you usually get your coffee, but this delightful show's a good reason to visit this venue at least once. *Aug. 27-Sept. 30.* Medici Roasting, 1101 West Lynn, 512/524-5049. papercommittee.com.

CLOSING

ART FOR THE PEOPLE: ABUNDANCE This show is called “Abundance” because that's what it represents: an *abundance* of bright new works from a plethora of local artists. *Through Aug. 26.* Art for the People, 1711 S. First, 512/761-4708. artforthepeoplegallery.com.

FLATBED PRESS: EDITION VARIABLES 2022 Here's the first annual exhibition to showcase **Austin's new and upcoming printmakers**, featuring work from students who are receiving their BFA, B.A., B.S., or MFA with a major or minor concentration in printmaking from an Austin-area college or university. *Through Aug. 27.* Flatbed Press, 3701 Drossett #190, 512/947-1073. flatbedpress.com.

IVESTER CONTEMPORARY: DREAM JOB This is a group show displaying **sketches, maquettes, and digital renderings** of the projects and ideas that the participating artists would pursue **if money, time, knowledge, and space weren't in the way.** Recommended. *Through Aug. 27.* Ivester Contemporary, 916 Springdale #107. ivestercontemporary.com.

MACC: SENDAS DE MI VIDA This new exhibit includes paintings from the past two years, vibrant artworks by **Blas E. Lopez** only now revealed to the public. *Through Aug. 27.* Emma S. Barrientos Mexican American Cultural Center, 600 River St., 512/974-3772. maccaustin.org.

LINK & PIN GALLERY: SUMMER STRUT Link & Pin presents a summer show featuring some of their **favorite Austin artists**; each artist (the amazing **Leslie Kell** among them) will have a work on display in the gallery, with additional pieces available online. *Through Aug. 28.* Link & Pin, 2235 E. Sixth #102, 512/900-8952. linkpinart.com.

THE UNBEARABLE LIGHTNESS OF BEING STUFFED Austin's own **Stuffed Animal Rescue Foundation** presents a literary homage in which stuffed writers display original works and new takes on old classics. Savor flash fiction, essays, and poetry from some of “the most talented stuffed authors of this generation.” *Through Aug. 28.* SARF HQ, 2825 Hancock #111. thesarf.org.

☀️ **YARD DOG: DESTINATION UNKNOWN** Chicago artist **Margie Criner** makes **organic-shaped sculptures** that house **tiny dioramas**, viewable through a peephole. These “sculptures in sculpture,” meticulously handcrafted, are miniature narratives hidden inside abstract sculpture, exploring the notion of vacancy in everyday places. *Through Aug. 28.* Yard Dog, 916 Springdale, 512/912-1613. yarddog.com.

REALLY SMALL MUSEUM: MELISSA CHAPMAN Through her work as a metalsmith, Chapman explores **the conflictual duality of American life**: on one hand, continued senseless gun violence; on the other, the desire we all share for our children (young and adult) to grow up safely and carefree. *Through Aug. 31.* 3509 Banton. Free. melissalynnchapman.com.

ONGOING

CARVER MUSEUM: PEACE TO THE QUEEN The photographer, humanitarian, and educator **Jamel Shabazz** presents a **career retrospective** spanning four decades of work, featuring **candid portraits of women of color** – as curated by **Ja'nell Ajani.** *Through Sept. 17.* George Washington Carver Museum and Cultural Center, 1165 Angelina, 512/974-4926. carver-museum.org.

CLOUD TREE: PLASTERED AND POSSESSED This is a two-woman exhibition of new paintings and sculptures by **Carly Weaver** and **Mariel Wilmoth.** *Through Sept. 11.* Cloud Tree, 3411 E. Fifth. cloudtreestudiosandgallery.com.

ICOSA: TERRA FIRMAMENT, PART 2 Here's the continuation of, the sequel to, **Matt Rebholz** and **Jana Swec's** exhibition from September 2021, the artists **vividly manifesting their personal histories** into **emotionally charged landscapes** steeped in narrative and individual mythology. *Through Sept. 17.* ICOSA, 916 Springdale #102, 512/920-2062. icosacollective.com.

Canvas: Glitch

Now on glorious display in this progressive Eastside gallery, **Sandra Boskamp's figurative paintings** combine **representational forms** with **surrealistic elements**, calling out the making of individuality behind modern filters, creating images that accentuate their subjects' qualities to create **layered, puzzlelike portraits.** *Opening reception: Sat., Aug. 27, 6-9pm.* Canvas, 1601 E. Cesar Chavez, 973/598-5624. canvasatx.com.



LORA REYNOLDS GALLERY: BLOW-UP Bing Wright's new pictures are **enlargements of uncommonly tight crops** from **images of children at play on a seashore** – an outstretched hand splashing water or carrying a beach bucket, liberal smears of sunscreen, fluorescent plastic hair clips, a foot dragging through burbling waves. *Through Sept. 10.* Lora Reynolds Gallery, 360 Nueces #50, 512/215-4965. lorareynolds.com.

LYDIA STREET GALLERY: REPAIRING NATURE / RIBBON OF LIFE This is a powerful dual exhibition of works by **Benné Rockett** and **Melanie Hickerson**. Rockett's current body of work, "Repairing Nature," utilizes Japanese traditions for imbuing worn and broken objects with new life. Hickerson's surreal narrative paintings in "Ribbon of Life" are rich with color and symbolism. *Through Sept. 11.* Lydia Street Gallery, 1200 E. 11th #109, 512/524-1051. lydiastreetgallery.com.

NORTHERN-SOUTHERN: MICE ELF, AGAIN The colorful creations of **Drew Liverman** supercharge this intimate powerhouse of a gallery Downtown, with paintings of "hot doom, the joys of love, bike rides, Olaf from *Frozen*, Goya's covens, and scraps of what could be something for a place to live, for a time." *Through Sept. 10.* Northern-Southern, on Fifth, between Brazos & San Jacinto. northern-southern.com.

SAGE STUDIO: BODY WORK Here's an exploration of **all things anatomical and automotive**, with **two-dimensional art** reflecting on **human bodies** and **three-dimensional sculptures** created around the theme of **auto bodies**. The show features pieces from 12 artists with intellectual and developmental disabilities – artists from Austin, New York, Philadelphia, Chicago, and California. *Through Sept. 17.* SAGE Studio, 916 Springdale Rd. Bldg. 2 #103. sagestudioatx.com.

UMLAUF SCULPTURE GARDEN The Umlauf's famed garden features the bronze or stone cynosures by **Charles Umlauf** and others anchoring sight among the bright foliage and tree-towered paths. *Tue.-Fri., 10am-4pm; Sat.-Sun., 11am-4pm.* Umlauf Sculpture Garden & Museum, 605 Azie Morton, 512/445-5582. umlaufsculpture.org.

WALLY WORKMAN GALLERY: SPACIOUS Julie Maren expands upon her use of negative space for this show, **exploring boundaries and ideas of infinity**, her paintings and installations heavily layered and simultaneously heavily redacted, with actual pieces of the canvas cut away. Gorgeous, yes, and unforgettable. *Through Sept. 4.* Wally Workman Gallery, 1202 W. Sixth, 512/472-7428. wallyworkmangallery.com.

WOMEN & THEIR WORK: THE FUTURE IS BEHIND US Rachel Wolfson Smith focuses our attention on **the essential and grounding effect of beauty in nature**, portraying constructed, intricate, and imagined landscapes. *Through Sept. 29.* Women & Their Work, 1311 E. Cesar Chavez, 512/477-1064. womenandtheirwork.org.

BOOKS

MEET THE MYSTERY AUTHORS Here's a bright clue toward solving any readerly boredom you may be experiencing of late: Join the bibliophilic crowd at BookPeople to celebrate **Jeff Abbott's**, **Taylor Moore's**, **Dixie Lee Evatt's**, **Helen Currie Foster's**, and **Gabino Iglesias'** new books. The event will include a moderated discussion with the authors, an audience Q&A, and a signing line. *Thu., Aug. 25, 7pm.* BookPeople, 603 N. Lamar, 512/472-5050. Free. bookpeople.com.

LAGERS & LITERATURE: A BOOK FAIR FOR ADULTS Seems there's always something awesome going on down at **Meanwhile Brewing** these days – *even besides the beer, we mean* – and now here's this **grownup book fair**, where you can shop local booksellers, learn about book and paper arts, explore archives and zines, sign up for or renew your library card, and more. Hey, the **Typewriter Rodeo** crew's gonna be there, too! Pro tip: Give Meanwhile's northwest IPA Disco in the Panic Room a whistle-wetting try (and you'll be hooked). *Sun., Aug. 28, noon-6pm.* Meanwhile Brewing Co., 3901 Promontory Point, 512/308-3659. Free. meanwhilebeer.com.



ESTHER'S FOLLIES

New Showtimes

Thursdays 7pm
Friday & Saturday
7pm & 9pm

Political Comedy! New Magic! Current Events!



**AWESOME
MERCH**

YOU CREATE,
WE MAKE.



MADE WITH LOVE
IN AUSTIN, TX

CREATE CUSTOM

NOTEBOOKS

100 POCKET NOTEBOOKS (3.5X5.5")

\$90

+ 1000 OTHER CUSTOM PRODUCTS

WWW.AWESOMEMERCH.COM

SPEAK TO US TODAY ABOUT YOUR
NEXT PRINT OR MERCH PROJECT!

✉ HELLO@AWESOMEMERCH.COM
☎ 512.456.3445



Honey Harvest Party

Celebrate **all things honey**, including the new **Hive Mind Honey Ale**, food tastings, an observation hive, demos, and educational activities for kids. *Sat., Aug. 27, noon-3pm. Vista Brewing, 13551 FM 150, Driftwood, 512/766-1842. Free. vistabrewingtx.com.*

GETTY IMAGES

DONATE BLOOD, GET FREE WINGS Bok bok! In August, blood donors get a tasty reward of a voucher for five chicken wings from Pluckers Wing Bar. *Through Aug. 31. We Are Blood donation centers and mobile drives. weareblood.org.*

END OF SUMMER SALE Get 20%-30% off in-store or online on jewelry, books, and locally made, artist-designed gifts and homeware. *Through Sat., Aug. 27. The Contemporary Austin at Laguna Gloria, 3809 W. 35th. thecontemporaryaustin.org.*

YMCA COMMUNITY GATHERING Let your voice be heard at an open house and community celebration where guests can provide input, learn about the Y, and celebrate the end of summer with treats and activities. *Thu., Aug. 25, 5-7pm: Springs Family YMCA, 27216 RR 12, Dripping Springs. Fri., Aug. 26, 5-7pm: YMCA Southwest Branch, 6219 Oakclaire, 512/322-9622. Free, but RSVP encouraged. betterunite.com/austiny-mca-communitygathering.*

MURDER MYSTERY DINNER A night of mayhem and mystery set in the Roaring Twenties. *Thu., Aug. 25, 6-9pm. Austin-area Pinball locations. pinballz.com.*

ARTIVISM: HOW TO CREATE SOCIAL CHANGE WITH ART Join Simon Tam of the Slants Foundation and the Asian American Resource Center for a special workshop on using art to create social impact, and learn about other Asian American artists who are making a real-world impact with their work. *Thu., Aug. 25, 6:30-8pm. Asian American Resource Center, 8401 Cameron, 512/974-1700. austintexas.gov/aarc.*

FRONT FEST 2022 Future Front brings back their jam-packed Front Fest with a music showcase featuring headliners We Don't Ride Llamas; a film showcase with screenings of "But Humble Sinners" and "Moondogs"; and a closeout Perreo Club pool day party. *Thu.-Sat., Aug. 25-27. Multiple locations. \$15/event; \$45, weekend pass. thefrontfest.com.*

FLOAT FILMS Celebrate the end of summer with a camp-centric film, a swim, and a counselor-approved cocktail. This last Float Film is summer-camp satire *Wet Hot American Summer*. *Fri., Aug. 26. Pool opens at 5pm, screening at dusk. Austin Motel, 1220 S. Congress. austinmotel.com.*

AUSTIN'S BIRTHDAY BASH The Downtown Austin Alliance Foundation celebrates the city's 183rd birthday with five family-friendly events including live music, creative arts, food, and the people who capture the true spirit and authenticity of Austin. Get all the details online. *Aug. 26 & 28. Republic Square, 422 Guadalupe. republicsquare.org.*

THE PEOPLE'S MARKET Las Ofrendas, Frida Friday ATX, and Downtown Austin Alliance Foundation host a market amplifying BIPOC, queer, and emerging creatives and entrepreneurs. This special edition is part of DAA's Austin Birthday Bash, and in honor of Women's Equality Day, Las Ofrendas curated an all-woman lineup, including an interactive art wall welcoming pieces from the community. Speakers including Council Member Natasha Harper-Madison, mayoral candidate Celia Israel, and City Council candidate Daniela Silva will share thoughts as well. Children's activities, dance, music, and more fun round out the evening. *Fri., Aug. 26, 6-10pm. Republic Square, 422 Guadalupe. Free. fb.com/fridafridayatx.*

TWO-STEP NIGHT Learn how to two-step for the first time or brush up on your skills with a lesson from Dancin' Austin (7pm), then show off your moves at the dance with live music (7:30-9:30pm). *Fri., Aug. 26. Jester King Craft Brewery, 13187 Fitzhugh. jesterkingbrewery.com.*

CACAO + SOUND CEREMONY An evening of cellular healing and deep relaxation. *Fri., Aug. 26, 7-9pm. Flow Yoga Westgate, 4477 S. Lamar. \$15-40 donation. flowyogatx.com.*

CD BABY'S DIY MUSICIAN CONFERENCE Apropos for the live music capital of the world, this conference will unite and excite musicians ready to take their careers to the next level. Hear speakers, attend workshops, get one-on-one mentorships, and jam with other musicians. Keynotes include superstar songwriters Kara DioGuardi and Ross Golan, who'll host a Shark Tank-style song critique sesh to workshop songs. *Aug. 26-28. Hilton Hotel Downtown, 500 E. Fourth. \$149; free for volunteers. diymusiciancon.cdbaby.com.*

IKEA FESTIVAL Musicians and music lovers will learn how to transform their creative spaces using IKEA products, including how to turn your living room into a dance floor. *Fri., Aug. 26, 9am. IKEA, 1 IKEA Way, Round Rock. Free. ikea.com.*

MACC DAY OF WELLNESS A full day of free outdoor wellness activities for all ages with refreshments (paletas, fruit, and water) and a 10-minute cooldown between each

class. It starts with a volunteer opportunity at the Healing Garden, continues with bilingual yoga and then meditation with Sana Yoga, and concludes with capoeira with Erick Salazar. *Sat., Aug. 27, 9am-1pm. Mexican American Cultural Center, 600 River. austintexas.gov/esbmacc.*

THE ULTRAPRENEUR SUMMIT A one-day interactive summit designed for young professionals (ages 16 and up) to build community with their peers and create social impact. Pitch ideas and get real-time feedback or investments, and get a fresh new headshot during the mix-and-mingle event. *Sat., Aug. 27, 10am-6pm. Huston-Tillotson University, 900 Chicon. Free. beultra.org.*

CANNAROCK Celebrate cannabis culture with a market, vintage bike show, dab bar, and live music from Chaw, Relative Saints, and more to be announced. *Sat., Aug. 27, 11am-5pm. Come & Take It Live, 2015 E. Riverside. cannarockatx.com.*

EASTSIDE MUSIC SCHOOL OPEN HOUSE Meet the teachers, tour the school, and sign up for a free lesson if you'd like to learn to sing or play an instrument. *Sat., Aug. 27, 11am-2pm. Eastside Music School, 501 N. I-35. Free. eastsidemusic.com.*

ARCHERY CLASS Learn the centuries-old sport from USA Archery Certified Level 3 coach Chris Ching at the historic farm. *Second & fourth Saturdays. Pioneer Farms, 10621 Pioneer Farms Dr. \$35-45. pioneerfarms.org.*

VINYL BAZAAR Buy, sell, and trade vinyl with local vendors like Cosmic Spinners, BLK Vinyl, Love Wheel Records, Antone's, Queer Vinyl Collective, Feels So Good, and more. *Sat., Aug. 27, noon-4:30pm. The Austin Beer Garden Brewing Co., 1305 W. Oltorf. theabgb.com.*

MUTINY MARKET It's a brunch market, baby, which means good finds, good drinks, and good food. *Sat., Aug. 27, 3-8pm. Hotel Vegas, 1502 E. Sixth. instagram.com/mutiny_market.*

BAT FEST Celebrate Bat City's famous million-plus Mexican free-tailed bats at a fest with music from about a dozen artists, including the Toadies, Chamillonaire, and Bun B, plus a variety of vendors, children's activities, and more. *Sat., Aug. 27, 4pm-12mid. Congress Avenue Bridge, 100 S. Congress. \$25; \$250, VIP. batfest.com.*

FLATWATER UNBREAKABLE NIGHT A night of FUN with music, dancing, and auctions to raise funds for nonprofit Flatwater Foundation, which supports cancer patients. *Sat., Aug. 27, 4-8pm. Historic Scoot Inn, 1308 E. Fourth. \$50 for tickets; \$20 for raffle ticket. flatwaterfoundation.org.*

BIG BROTHERS BIG SISTERS ICE BALL 2022 Join Big Brothers Big Sisters for an evening of cocktails, hors d'oeuvres, a seated dinner, live and silent auctions, live music, and more. It's an exciting evening benefiting the nonprofit that serves 800 children each year and aims to provide mentoring services to 200 more. *Sat., Aug. 27, 6pm. JW Marriott Austin, 110 E. Second. \$500. austiniceball.org.*

DADAGEEK SUMMER 2022 EXHIBITION Join IRL or virtually for an evening of inspiring tech art and music from the international dadageek community. *Sat., Aug. 27. In person, 7pm; livestream, 8pm. dadaLab, 2824 Real, 512/222-8380. \$5. dadageek.com.*

LE GARAGE SALE Tackle your back-to-school shopping with dozens of boutique and designer vendors under one roof, and feast on the bargains as every rack is a sale rack. *Sat.-Sun., Aug. 27-28, 11am-5pm. Early shop: Sat., 9:30-11am. Palmer Center, 900 Barton Springs Rd. \$10; \$25, VIP early shop. legaragesale.net.*

CARS & COFFEE Fun for the whole family with an eclectic car show and meetup with on- and off-track action at COTA. *Sun., Aug. 28, 8am-noon. COTA, 9201 Circuit of the Americas Blvd. Free; \$10 to register a car for show. circuitoftheamericas.com.*

UNCOMMON FLEA Uncommon Objects' big backyard is transformed into a dynamic marketplace for all things vintage, found, and made. Come join the fun and feast on the bargains! *Last Sundays, 10am-3pm. Uncommon Objects, 1602 Fortview, 512/442-4000. uncommonobjects.com.*

CHESS CLUB PRESENTS: BEACH BOP BOAT BANGER Annabelle Chairlegs, Rattlesnake Milk, and Ryan Sambol play a boat party on Lake Travis with sun and swimming. *Sun., Aug. 28, 4-8pm. Beach Front Boat Rentals, 16120 Wharf Cove, Volente, 512/258-8400. \$35-40. link.dice.fm/BeachBop.*

CUP SALE & ZINE RELEASE FUNDRAISER Broad Studios Club House artists will sell cups in support of Deeds Not Words, in conjunction with the release of *The Galvanizer*, an art and policy zine project that incorporates art to tell stories, raise awareness, and inspire action. *Sun., Aug. 28, 4-8pm. Kinda Tropical, 3501 E. Seventh. Free. kindatropical.com.*

CONTINUED ON P.34



PHOTO BY AUSTIN WHITE CC BY 2.0

National Dog Day

National Dog Day is Fri., Aug. 26, and we've rounded up several ways to **celebrate with your furry friends**. Plus, see our photo gallery of staff members and their dogs at austinchronicle.com/photos.

NATIONAL DOG DAY AT HEARTH & SOUL Celebrate your furry friend with a photo contest to win a \$200 gift basket. Call 512/474-SOUL (7685) to reserve a spot. *Fri., Aug. 26, 10am-6pm. Hearth & Soul, 2727 Exposition. hearthandsoul.com.*

NATIONAL DOG DAY PARKING LOT PARTY Bring the whole family for music, face-painting, cornhole, and local dog-focused businesses such as Kim Ortiz Portrait Art, Camp Bow Wow, and Lucky Lab Rescue and Adoption. *Fri., Aug. 26, 4pm. Bee Cave Orthodontics, 11412 Bee Caves Rd. #300. beecaveortho.com.*

NATIONAL DOG DAY IN KYLE The Kyle Parks & Rec Department will give out goodie bags for the first 20 good boys and girls on their special day. *Fri., Aug. 26, 5-7pm. Steeplechase Dog Park, 135 Hallie Dr., Kyle. cityofkyle.com.*

NATIONAL DOG DAY YAPPY HOUR Celebrate National Dog Day with some tail-waggin' fun! Have your pup's picture taken at the Doggie Vacation photo booth, with each photo including entry in a raffle to win a doggone good prize. *Fri., Aug. 26, 5-7pm. Blue Owl Brewing, 2400 E. Cesar Chavez, 512/593-1262. blueowlbrewing.com.*

NATIONAL DOG DAY AT LORO The Asian smokehouse and bar partners with local bakers Pawstin Barkery so you can treat your furry friend to freshly baked dog biscuits made with peanut butter, bananas, and Loro beef tallow. Talk about gourmet! *Fri., Aug. 26. Loro, 2115 S. Lamar, 512/916-4858. lroreats.com.*

COMMUNITY

BY JAMES SCOTT

WHAT'S YOUR SIGN? The zodiac question comes up from time to time, esp in the small queer dating circles we're all spinning through. Does the placement of some big gas bodies up in space really mean you're good at solving puzzles, or tempestuous, or ruled by the feet? Probably not, but astrology remains a fixture in the "using mysticism to make my decisions" community, joined by tarot cards, online yes-or-no generators, and people who call themselves empaths. This week, I figured I'd let the stars guide the Qmmunity listings and give y'all your homosscopes: queer events recommended based on your zodiac sign. ■



"But Humble Sinners" screens as part of Capricorn-rec'd Front Fest

COURTESY OF FUTURE FRONTTX

~ HOMOSCOPIES ~

AQUARIUS

ALL ABOUT ANAL A workshop on anal sex that discusses tushie tips, techniques, and toys. Sun., Aug. 28, 6pm. Forbidden Fruit, 108 E. North Loop. \$20. forbiddenfruit.com.

CLARA BLACKSTONE This chain-smoking trans comic-about-town headlines the Fallout. Fri., Aug. 26, 8pm. Fallout Theater, 616 Lavaca. \$15 online; \$20 door. falloutcomedy.com.

LIBRA

SUMMER SPLISH SPLASH & MARKET A community-centered pool party celebrating the end of summer. Sun., Aug. 28, 2-6pm. East Austin Hotel. 1108 E. Sixth. Pool, \$25. fridafridayatx.com.

BREW PAUL'S DRAG SHOW Start your engines with host Eileen Dover. Sat., Aug. 27, 8:30pm. Meanwhile Brewing Co., 3901 Promontory Point.

GEMINI

TRANSY WARHOL, DREAM REAMER, THE PINKY RINGS, KING CLAM MUSIC Fri., Aug. 26, 9pm. Valhalla, 710 Red River. \$10. valhallatavern.com.

CHEER UP CHARLI XCX Brigitte Bandit and Cyber Queen are calling all "Hot Girls" for this Charli XCX tribute party. Sat., Aug. 27, 9pm. Cheer Up Charlies, 900 Red River.

PISCES

QUEERING RELATIONSHIPS Learn how to navigate queer relationships while working on a guided watercolor painting. Tue., Aug. 30, 6:30-8pm. Virtual. allgo.org.

CANCER

COMMUNITY VINYL SWAP Join Queer Vinyl Collective and bring your three best swappin' vinyls. Sun., Aug. 28, 10am-3pm. Try Hard Coffee Roasters, 1115 E. 11th. instagram.com/queervinylco.

LEO

PANTHEON The gods of expression deliver a variety show full of seraphic performances from local artists. Fri., Aug. 26, 9pm. Cheer Up Charlies, 900 Red River.

SCORPIO

DIÉ FELICIA! Louisiana Purchase gives pure drag terror. Fri., Aug. 26, 10pm. Elysium, 705 Red River. \$10. fb.com/elysiumaustin.

VAVA DOOM: METALESQUE A tribute to the dark, evil, mystical, and metal among us. Sun., Aug. 28, 8-10pm. Valhalla, 710 Red River. \$15-100. fb.com/valhallatavern.

ARIES

HOUSE OF VENENO All the El Paso hotties take over at this month's Cuchi Cuchi. Sat., Aug. 27, 9pm. Cuatro Gato, 310 Colorado. instagram.com/cuchicuchi_atx.

REVELATIONS Host Nazareth weaves each drag performance together in an elaborate storytelling session. Fourth Saturdays, 7pm. Oilcan's, 211 W. Fourth.

SAGITTARIUS

QUEER TRIVIA: BACK TO SCHOOL With host Aira Juliet. Tue., Aug. 30, 7:30pm. Wanderlust Wine Co., 702 Shady Ln. instagram.com/thelittlegayshop.

QUEER VEGAN HIKE AND LUNCH. Sat., Aug. 27, 10:30am-1:30pm. Zilker Park gravel lot, 2228 Stratford.

TAURUS

GIRL BLUNTZ Puff puff but don't pass up this night of stoner fun. Thu., Aug. 25, 9pm. Coconut Club, 310-B Colorado. instagram.com/lavenderthug.

VIRGO

QUEER YOGA An hour of hot yoga led by a queer non-binary instructor. Sundays, 10:30am. Black Swan Yoga, 1417 W. Anderson. Donation based. blackswanyoga.com.

CAPRICORN

FRONT FEST 2022 Future Front brings back their jam-packed fest with a music showcase, a film showcase, and a closeout Perreo Club pool party. Thu.-Sat., Aug 25-27. Multiple locations. \$15 per event; \$45 weekend pass. thefrontfest.com.

For more Qmmunity listings see austinchronicle.com/qmmunity and send yer queer events to jscott@austinchronicle.com.

Austin EASTCIDERS

1530 BARTON SPRINGS RD.

- Free parking garage
- Shady outdoor patio w/fans & misters
- Air-Conditioned indoor dining

COCKTAILS, CIDER, PIZZA, MUSIC & MORE!
Featuring EASTCIDERS BOURBON & VODKA

Happy Hour Specials 2-5pm, Monday - Friday:
½ off Pizzas, \$1 off Cocktails, \$4 Ciders!

THU 8/25: geeks who drink TRIVIA 7PM

FRI 8/26: LIVE MUSIC WITH DATURA 7-9PM

SAT 8/27: BRUNCH, LUNCH, DINNER, & DRINKS!

SUN 8/28: SUNDAY FUNDAY

MON 8/29: NOW OPEN 11AM-8PM

TUE 8/30: HAPPY HOUR 2-5PM

WED 8/31: HAPPY HOUR 2-5PM

Austin EASTCIDERS COLLABORATORY

979 SPRINGDALE RD.

- Free surface parking
- Indoor & Outdoor seating
- Dipping Springs Food Truck

CIDER, FOOD TRUCK & MORE!

Happy Hour Specials 2-5pm, Tues - Fri: \$4 Ciders!

THU 8/25: HAPPY HOUR 2-5PM
TEACHER THURSDAYS 1/2 OFF ALL DAY

FRI 8/26: HAPPY HOUR 2-5PM

SAT 8/27: CIDER SIPPIN' SATURDAYS

SUN 8/28: SUNDAY FUNDAY

MON 8/29: CLOSED

TUE 8/30: HAPPY HOUR 2-5PM
CLIMBER SPECIALS 1/2 OFF ALL DAY

WED 8/31: HAPPY HOUR 2-5PM
SERVICE INDUSTRY 1/2 OFF ALL DAY

The OFFICIAL CIDER OF AUSTIN FC

LUBE!

AVAILABLE IN SILICONE AND WATER-BASED

CAPABLE OF HELPING YOU CONQUER YOUR **BIGGEST & HARDEST** CHALLENGES, THIS LUBE IS A JEWEL IN YOUR DARK ROOM.

DOUBLE SCORPIO.COM

DOUBLE SCORPIO

Make sure you don't miss any of the action!



Westlake Eye Specialists
The Art of Eye Surgery
512-472-4011 • westlakeeyes.com

SUPPORT FREE PRESS

Please consider supporting *The Austin Chronicle*. For just a few bucks, you can help us keep delivering the news.

AUSTINCHRONICLE.COM / **SUPPORT** THE AUSTIN CHRONICLE



**Home of the Kansas City Chiefs
and Arsenal FC**



JOHN ANDERSON

Merlin Tuttle Day

Mayor Steve Adler proclaimed Aug. 26 as **Merlin Tuttle Day** to honor his success in saving the city's world-famous bats. Celebrate with a **bat party** with food, drinks, storytelling, bat-watching, a Q&A, and a chance to win a signed and matted print and **more prizes**. Join virtually at 7:30pm for the storytelling portion for only \$10. Sales and donations support nonprofit **Merlin Tuttle's Bat Conservation**. *Fri., Aug. 26, 6:30-9:30pm. Capital Cruises, 208 Barton Springs Rd., 512/480-9264. \$100. merlintuttle.org.*

COMMUNITY CONTINUED FROM P.32

GODDESS GATHERING Gather with inspiring women to connect, meditate, share stories, and build sisterhood. *Sun., Aug. 28, 2-4pm. Flow Yoga, 202 Walton Way #200, Cedar Park. \$20-40. flowyogabx.com.*

CIRCULAR AUSTIN SHOWCASE An in-person pitch event hosting a diverse group of people from investor and business communities to support and inspire growth in the circular economy. *Tue., Aug. 30, 5:30-8pm. The Cathedral, 2403 E. 16th. Free. austinyc.org.*

JOURNEY INTO EXPANSION Drop into the theta state during this journey of the mind, body, and spirit. *Tue., Aug. 30, 7-10pm. Flow Yoga, 4477 S. Lamar. \$25-40. flowyogabx.com.*

SOUND CHECK ON TRACE PATIO: NICK SWIFT A free concert where you can meet an adoptable dog and bring donations for Austin Animal Center. *Wed., Aug. 31, 8-10pm. W Hotel, 200 Lavaca, 512/542-3600. Free. traceaustin.com.*

CIVICS 101

CITY COUNCIL REGULAR MEETING Council gets back into the swing of things with a heavy agenda. *Thu., Sept. 1, 10am. City Hall, 301 W. Second. austintexas.gov/council.*

CLIMATE ACTION HAPPY HOUR Join the Austin chapter of Citizens' Climate Lobby for fun and discussion. *Sun., Aug. 28, 12:30-2pm. Beerburg Brewing, 13476 Fitzhugh. Free. climateactionhappyhour.com.*

ELIMINATING RECYCLING CONTAMINATION Austin Resource Recovery staff will give out goodies, answer questions, and talk about common blue cart "oopsies" to help you recycle right. *Sun., Aug. 28, 10am-2pm. Mueller Farmers Mkt., 4550 Mueller. Sat., Aug. 27, 9am-1pm. Lakeline Farmers' Mkt., 11200 Lakeline Mall Dr. austintexas.gov/arr.*

TRAVIS COUNTY COMMISSIONERS COURT VOTING SESSION Watch the meeting live on TCTV. *Tuesdays, 9am. Commissioners Court, 700 Lavaca. traviscountytx.gov.*

**Add Some
Burnt Orange
to Your Resume**

extendedcampus.utexas.edu



The University of Texas at Austin
Extended Campus

AUSTIN FC INTRODUCES EMILIANO RIGONI AS LAFC CLASH LOOMS

It's no mystery who **Austin FC** will be measured against as we head toward the business end of the MLS regular season and into the playoffs. That would be the black-and-gold football club from Los Angeles. Current Western Conference (and MLS) leaders with 18 wins and 57 points, **LAFC** descends upon Austin this week for a highly anticipated meeting at **Q2 Stadium** Friday night.

Although the Verde and Black are positioned to sweep the season series between the clubs with a victory at home, keeping pace with LAFC in the standings has proven thus far to be a gargantuan task not just for Austin FC, but for everyone in the West. Making matters tougher, and to the credit of LAFC's first-year manager **Steve Cherundolo**, general manager **John Thorington**, and long list of co-owners (**Will Ferrell**, **Magic Johnson**, **Mia Hamm**, **Nomar Garciaparra**, and **Tony Robbins** all included), the Angelenos have managed to dominate the off-field battleground this season just as much as the on-field one.

No team in MLS produced a more bountiful midseason transfer window than LAFC, who added European legends **Giorgio Chiellini** and **Gareth Bale**, as well as a new Designated Player in Gabon international winger **Denis Bouanga**, to an already elite squad of talent headlined by **Carlos Vela**. And they may not be finished, as multiple reports this week indicated LAFC is close to acquiring free agent and former Barcelona winger **Cristian Tello**.

"We did not feel like now was a good time to get complacent," Thorington said of the bevy of summer signings.

That right there is music to any fan's ears. It's also a statement of intent to the rest of the league: LAFC is ready for an arms race.

And in its own way, Austin FC has answered the challenge. The club on Monday held a press conference at Q2 Stadium to formally introduce its own newest Designated Player: 29-year-old Argentine winger **Emiliano Rigoni**, signed for a reported fee of \$4 million from Brazilian club **São Paulo**. You knew it was a big occasion, because **Josh Wolff** wore a blazer over his signature polo shirt.

"His quality is clear. His personality is fantastic. We're fortunate to catch a player of



New Austin FC Designated Player Emiliano Rigoni fields questions during an introductory press conference

COURTESY OF AUSTIN FC

his quality and his age, and he's a player that is going to make us better," Wolff said. "We certainly feel and expect that Emiliano can [provide a boost]."

Rigoni, who will wear No. 77 for the club, radiated the same confidence and charisma possessed by his friend and former-turned-current teammate **Sebastián Driussi**, with whom he previously played at **Zenit St. Petersburg**. "I've known Seba for several years," Rigoni said of Driussi. "We played almost three years together in Russia. There we had a very beautiful chemistry both on and off the pitch. I know him very well and all his characteristics, and he knows mine. Because of this I think we can do great things on the pitch together."

Rigoni described himself as a dynamic right winger, comfortable with the ball on either foot, who seeks out one-on-one opportunities against opposing defenders. "He'll help us generate goalscoring chances," Wolff said. "We're one of the highest-performing attacking teams right now, and he's only going to elevate that."

Although Rigoni will have had less than a week of training with Austin FC, Wolff wouldn't rule out Friday's match against LAFC for the Argentine's debut, though he indicated that the following match may be more likely. But if Wolff does call his number against the MLS leaders, Rigoni won't be easily star-struck or intimidated.

"Los Angeles doesn't scare me at all," he quipped. ■

CANNAROCK

AUGUST 27TH | 11-5PM | COME AND TAKE IT LIVE



ADVOCACY
LOCAL SHOPS
GIVEAWAYS

LIVE MUSIC
VIP DAB BAR
FAMILY FRIENDLY

BIKE SHOW
FOOD TRUCKS
FREE ENTRY

WWW.CANNAROCKATX.COM

GET YOUR FREE TICKETS TODAY!



2013 Wells Branch Pkwy
(near Q2 stadium)

Seafood Season is Here!

Come load up on King Crab,
Snow Crab, Gulf Oysters,
and Head-on Shrimp
before or after the match

Full selection of beers
and frozen bar drinks!

Online Ordering Available

ALL SCHOLARS.
COLLEGE READY.

NOW ENROLLING

AUSTIN ACHIEVE
PUBLIC SCHOOLS

austinachieve.org/enroll 512-522-4190



Want the latest Austin FC news delivered straight to your inbox? Subscribe at austinchronicle.com/newsletters.

SPORTS

THE MAIN EVENT

📍 **PBR TEAM SERIES: AUSTIN GAMBLER DAYS** The Austin Gamblers open their debut season hosting an action-packed team bull-riding competition with the most exciting eight seconds in sports, along with great food, music, and nonstop entertainment. Country star Kane Brown kicks it all off with a pre-show concert Friday, and on Saturday, head over to Stubb's beforehand for Fan Fest (11am-6pm) with a mechanical bull, meet & greets, and more before the games. *Fri.-Sun., Aug. 26-28. Moody Center, 2001 Robert Dedman. austingamblers.com.*

📍 **INSPIRE A.D. WRESTLING** Inspire After Death pro wrestling returns with a live TV taping called "The God Complex." *Thu., Sept. 1. Pinballz Arcade Lake Creek, 13729 Research. \$25-35. inspireafterdeath.com.*

THE HOME TEAMS

📍 **UNIVERSITY OF TEXAS Soccer** The Horns play North Carolina Thursday (7pm) and Florida Sunday (3pm). *Aug. 25 & 28. Mike A. Myers Stadium, 707 Clyde Littlefield Dr. Volleyball The Horns play Minnesota in their first regular-season home game after facing Ohio State on the road. *Wed., Aug. 31, 7pm. Gregory Gym, Speedway & 21st, UT campus. texasports.com.**

📍 **ST. EDWARD'S Volleyball** Hilltopper Classic. *Fri.-Sat., Aug. 26-27. Recreation & Athletics Center, 3001 S. Congress. Soccer Vs. Emporia State University Sunday, then Univ. of Colorado Colorado Springs Tuesday. *Aug. 28 & 31, 1pm. Lewis-Chen Field, 3001 S. Congress. gohilltoppers.com.**

📍 **AUSTIN FC** It's a busy week at Q2 as the theme face LAFC Friday (7pm) then Portland Wednesday (8pm). *Aug. 26 & 31. Q2 Stadium, 10414 McKalla Place. austinfc.com.*

📍 **VIOLET CROWN ROLLER DERBY TRYOUTS** Join a preliminary tryout and practice if you're interested in competing with the team in Phoenix in September. Official tryouts will take place in late September. *Fri., Aug. 26, 7pm. Rock Sports Arena, 3918 Gattis School Rd. #102, Round Rock. fb.com/violetcrownrollerderby.*

📍 **TEXAS ROLLER DERBY** A bout with the theme "Be Your Own Hero." *Sat., Aug. 27, 7pm. Thunderdome, 1131 S. Loop 4, Buda. txrd.com.*

📍 **TEXAS ROLLERGIRLS** The temps won't be the only thing in the 90s at this themed scrimmage, "Hit Me Baby One More Time vs. Smells Like Derby Spirit," which promises to be full of grungy goodness and big pop hits. BYO chair, sunscreen, plus maybe some Dunkaroos and Surge. *Sat., Aug. 27, 8pm. Pan Am Park, 2100 E. Third. texasrollergirls.org.*

📍 **ROUND ROCK EXPRESS** Vs. Oklahoma City. Bring two canned goods to get in free Tuesday and benefit Round Rock Area Serving Center, bring a furry friend Thursday for Pints & Pups, see a pregame ceremony for Hall of Fame inductee Kirk Saarloos Friday, and more - get the full schedule of events online. *Aug. 30-Sept. 4. Tue.-Sat., 6:35pm; Sun., 1:05pm. Dell Diamond, 3400 E. Palm Valley Blvd., Round Rock, 512/255-2255. rrexpress.com.*

RECREATION & FITNESS

📍 **FARM YOGA** Enjoy a peaceful yoga session preceded by a quick succulent care class with East Austin Succulents, then explore the farm. *Every other Saturday, 8:30am. Boggy Creek Farm, 3414 Lyons. \$30. swiftfitevents.com.*

📍 **FITNESS IN THE PARK** Austin Parks Foundation presents a kickboxing class taught by a certified instructor from It's Time Texas. *Sat., Aug. 27, 10-11am. Pan Am Park, 2100 E. Third. Free. austinparks.org.*

📍 **PIYO WITH LIVE DJ** Teachers from Shed Pilates + Fitness and Body Collective will offer rotating Pilates and yoga classes all month. *Sundays, 9-10am. Body Collective, 5501 N. Lamar Ste. C-111. Free. fb.com/austinbodycollective.*

📍 **BALLET AUSTIN'S ANNUAL FREE DAY OF DANCE** Come dance! Alvin Ailey wrote, "Dance is for everybody. I believe that the dance came from the people and that it should always be delivered back to the people." So BA brings it with classes ranging from ballet to West African dance, for a great way to end the summer. *Sun., Aug. 28, noon-5pm. Ballet Austin, 501 W. Third. Free. balletaustin.org.*

📍 **PARTNER THAI YOGA WORKSHOP** Partners will strengthen their relationship as well as the body. *Sun., Aug. 28, 2-5pm. Flow Yoga, 2167 W. Anderson. \$25-40. flowyogabx.com.*

📍 **BENEFIT YOGA CLASS** Join a free class raising funds for nonprofit Flatwater Foundation, which provides mental health services to cancer patients. *Tue., Aug. 30, 6pm. Black Swan Yoga, 403 Orchard St. flatwaterfoundation.org.*



Austin Train Show

Fun for the whole family, this is not to be missed if you're a fan of **model trains**. Buy and sell trains, view intricate displays, enter the raffle to win a complete set, and **let the young'uns take a spin** on the **Kiddie Express** train. *Aug. 27-28. Sat., 10am-5pm; Sun., 10am-4pm. Palmer Events Center, 900 Barton Springs Rd. \$8 weekend pass. palmereventscenter.com.*

📍 **REPUBLIC SQUARE PARK FITNESS** A free total-body boot camp for all fitness levels. *Wednesdays, 6-8pm. Republic Square, 422 Guadalupe, 512/381-1147. Free, but RSVP. republicsquare.org.*

RUNS, WALKS, & RIDES

📍 **CRITICAL MASS** Celebrate cycling and take back the streets in one of two massive social rides, or try to hit both! *Fri., Aug. 26, 6pm. Pfluger Pedestrian Bridge, Lamar & Riverside. Free. fb.com/groups/austintxmass. Fri., Aug. 26, 7:30pm. 15 Chicon. fb.com/ridebikesaustin.*

📍 **BEAT THE HEAT 5K** The Kyle Professional Firefighters Association (Local 4567) and the Kyle Fire Department present their first 5K, with proceeds benefiting firefighters and their families. *Sat., Aug. 27, 7:30am. Mary Kyle Hartson Park, 204 Miller St., Kyle. \$20. athleteguild.com.*

KIDS

📍 **GOLDFISH SWIM SCHOOL GRAND OPENING PARTY** Celebrate with free shaved ice, a bounce house, scavenger hunts, and more family-fun activities. *Sat., Aug. 27. Goldfish Swim School, 8038 Mesa. Free. goldfishswimschool.com.*

📍 **BRUNCH BUNCH** Enjoy kid-friendly entertainment like drag storytelling or balloon animals. *Last Sundays, 10am-noon. Jo's Coffee Red River, 1000 E. 41st. joscoffee.com.*

📍 **COMMUNITY NIGHT AT THINKERY** Thinkery provides admission by donation as part of its Open Door Initiative, created to give every child a chance to explore STEAM concepts and develop a lifelong love of learning, regardless of means. *Sundays, 3-5pm. Thinkery, 1830 Simond, 512/469-6200. thinkeryaustin.org.*

📍 **ORPHEUS ACADEMY OF MUSIC OPEN HOUSE** Meet the director, tour the school, take a free lesson, and learn about options for fall music classes. *Sun., Aug. 28, 2-4pm. Orpheus Academy of Music, 3109 Kenai Dr., Cedar Park. Free. orpheusacademy.com.*

📍 **PLANET PROTECTORS** Kids ages 5 and up will learn from the Planet Protectors - Commander Sustainability, Captain Aerial, Hydro Crusader, and Agent Leaf - as they share tips on how to take better care of the planet. *Wed., Aug. 31, 4:30-5:30pm. University Hills Branch Library, 4721 Loyola, 512/974-9940. library.austintexas.gov.*

OUT OF TOWN

📍 **GILLESPIE COUNTY FAIR** The state's oldest continuously operated county fair presents a lineup of livestock events, music, vendors, exhibits, and more. *Thu.-Sun., Aug. 25-28. Fredericksburg. gillespiefair.com.*

📍 **SPEAKING OF THE DEAD: INTRIGUING STORIES OF CALDWELL COUNTY'S PAST** The local theatre company portrays people from the town's colorful past as a fundraiser for the County Historical Commission. *Fri.-Sun., Aug. 26-28. Lockhart. \$15. mygbt.org.*

📍 **LIVE PARI-MUTUEL HORSE RACING** Quarter horse and thoroughbred races with a post time of 1pm are a highlight at the county fair. *Sat.-Sun., Aug. 27-28. Fredericksburg. \$10. gillespiefair.com.*

📍 **113TH BIRTHDAY CELEBRATION FOR PRES LYNDON B. JOHNSON** The national park remembers the former president with a wreath-laying ceremony at his grave at 10am, and then a party at the state park from 9am to 2pm. *Sat., Aug. 27. Stonewall. nps.gov/ljjo.*

📍 **GRAPE STOMP** Join the fun tradition of squeezing the grapes with your feet at this first-come, first-served event with light snacks and wine available for purchase. *Sat.-Sun., Aug. 27-28 & Sept. 3-4. Becker Vineyards, Stonewall. Free. beckervineyards.com.*

DAY TRIPS BY GERALD E. MCLEOD

Forts Concho, Lancaster, and Richardson were once part of the thin blue line on the Texas frontier. They are now portals into the past.

Immigration exploded after Texas obtained statehood in 1845. The Army had the impossible task of separating the newcomers from the Indigenous people while protecting the roads to California.

Fort Concho (fortconcho.com) was the regimental headquarters for other forts established after the **Civil War**. At full strength between 1867 and 1889, the outpost housed 400 to 500 soldiers, including the famous **Buffalo Soldiers**.

The city of **San Angelo** preserves 24 of the post's buildings as a museum. Self-guided tours are available for a small fee. The museum hosts events throughout the year, including **Buffalo Soldier Heritage Day** and **Christmas at Fort Concho**.

Fort Lancaster (thc.texas.gov/historic-sites/fort-lancaster-state-historic-site), 33 miles west of **Ozona**, has the distinction of being the only Texas fort attacked by Native Americans. Part of a pre-Civil War line of forts, the post protected the **San Antonio-El Paso Road** from 1855 to 1862. Infantry troops mounted on mules fought **Comanche** and **Apache** warriors.

The post's chimneys and stone walls of 29 buildings stand as final sentinels at this **Texas Historical Commission** site. The museum in the visitors center remembers the people who occupied the remote outpost.



Fort Richardson (tpwd.texas.gov/state-parks/fort-richardson) was active between 1867 and 1878, and saw some of the heaviest fighting due to its proximity to **Oklahoma. General William T. Sherman** narrowly avoided being ambushed near here.

Today it is part of **Fort Richardson State Park** near **Jacksboro**. Several buildings have been restored, including the two-story hospital. A separate area of the park offers cabins, camping, fishing, swimming, and a 9-mile horse and bike trailway.

1,615th in a series. Everywhere is a day trip from somewhere. Follow "Day Trips & Beyond," a travel blog, at austinchronicle.com/daily/travel.



PBR
GAMBLER
DAYS
 POWERED BY
DELLTechnologies

AUGUST
26-28
 MOODY CENTER

20%
OFF
 INDIVIDUAL DAY
 PERFORMANCES

UNLOCK CODE:
CHRON



FRIDAY, AUGUST 26TH

PRE-SHOW CONCERT
 FEATURING **KANE BROWN**

MOODY CENTER

DOORS OPEN **6:30PM**
 CONCERT BEGINS **7:45PM**
 PBR TEAM SERIES **8:45PM**



SATURDAY, AUGUST 27TH

FAN FEST

11:00AM - 6:00PM
AT STUBB'S

EVENT WILL FEATURE BBQ, BEER, LIVE MUSIC WITH CALDER ALLEN, KELLEY JAMES, KYLE PARK, AND PUSH & SHOVE, MEET AND GREET WITH THE RIDERS, MECHANICAL BULL, PHOTO OPPS, WESTERN RETAIL, FREE GIVEAWAYS, AND MORE!

PBR TEAM SERIES

6:45PM AT MOODY CENTER

CHEER ON YOUR HOME TEAM, THE AUSTIN GAMBLERS, AS THEY DEFEND THEIR TURF IN AN ACTION PACKED BULL RIDING EVENT.

AFTER PARTY

9:00PM - 12:00AM
AT STUBB'S

THE PARTY WON'T STOP WHEN THE BULL RIDING ENDS. HEAD BACK TO STUBB'S FOR SOME COLD DRINKS AND LIVE MUSIC BY JESSE DAYTON AND THE BAND OF HEATHENS TO END THE NIGHT!

SUNDAY, AUGUST 28TH

COWBOY CHURCH

BROUGHT TO YOU BY AWARD-WINNING
PASTOR RANDY PHILLIPS

DOORS OPEN **11:00AM**
 CONCERT BEGINS **11:30AM**
 PBR TEAM SERIES **12:15PM**





System Failure Exposed in *Breaking*

John Boyega brings tragic life to a true crime story of a veteran betrayed by bureaucracy **BY STEVE DAVIS**

From the start, tense hostage thriller *Breaking* wants you to side with the polite African American man in a gray hoodie who passes a scribbled note informing a bank teller he's carrying a bomb. And with good reason. In the opening scene preceding this declaration, two security guards drag a wailing Brian Brown-Easley (an excellent Boyega) from an office building and roughly deposit him face down on the sidewalk outside the entrance. Once unshackled from handcuffs, Brian embarrassedly wipes the tears from his bruised face as a nearby woman hands him his eyeglasses in a gesture of kindness. So, what has happened to this broken man up to the moment of this public humiliation? It's a bang-up way to begin a movie that thrives on demonstrating empathy for someone helplessly swallowed whole by a depersonalized system that ultimately harms more than it helps.

The based-on-a-true-story screenplay is adapted by director Corbin and Kwame Kwei-Armah from a 2018 online investigatory article

in *Task & Purpose*, "They Didn't Have to Kill Him": The Death of Lance Corporal Brian Easley." It soon reveals why the traumatized Brian subsequently enters a Wells Fargo branch

in suburban Marietta, Ga., to demand a very specific amount of money. We soon learn this psychologically scarred Iraq War veteran isn't detaining his two understandably frightened but sympathetic female bank employee hostages (Beharie and Leyva) for anything like a ransom or extortion payment. Rather, the decorated former Marine with a patient ex-wife (Washington) and adored grade-

school daughter (Covington) has staged this seemingly desperate act to publicize his insensitive treatment by the Department of Veterans Affairs, whose bureaucratic practices have redirected a lifeline disability check to cover a debt and left him without any financial means to pay rent or feed himself. No question he's a slightly disturbed individual (there are hints of post-traumatic stress disorder), but all he

★ BREAKING

D: Abi Damaris Corbin; with John Boyega, Michael Kenneth Williams, Nicole Beharie, Selenis Leyva, Olivia Washington, London Covington, Connie Britton, Jeffrey Donovan. (PG-13, 103 min.)

★★★

NEW REVIEWS

BEAST

D: Baltasar Kormákur; with Idris Elba, Iyana Halley, Leah Sava Jeffries, Sharlto Copley. (R, 93 min.)

Dr. Nate Samuels (Elba), whose estranged wife has just died, takes his two teen daughters to South Africa to where their mother grew up. The girls, Mere (Halley) and Norah (Jeffries), aren't particularly happy with their dad right now. They feel he abandoned them and their mom while she was dying of cancer. Nate believes the trip will bring the girls closer to him and their mother with this visit to her homeland. Uncle Martin (Copley) is there to greet him. He grew up with Samuels' wife and is a lifelong friend. Martin is going to give them a "behind-the-scenes" look at the game reserve he runs. Sounds a bit familiar, right?

Beast is like a throwback to the good old days of *Jaws* rip-offs and the "when animals attack" movies. Now, I adore those movies; *Grizzly* and *Day of the Animals* from William Girdler, any number of Bigfoot movies like *Night of the Demon*, and one of my favorites of all time, Joe Dante's *Piranha*. So *Beast* is basically *Jaws* on safari.

The story isn't particularly strong here. There's the requisite exposition dump in the first 20 minutes and then it's off to the races as the actors do what they can with what they've been given. Both Halley and Jeffries manage to hold their own against Elba. I feel like Elba is one of the best working actors we have, and I'd love to see him be given something more along the lines of *Luther*, his excellent TV show from the last decade, but director Kormákur (*Everest*, *Adrift*) doesn't do anything particularly special here. This could've easily been made as a 1970s TV movie like *Devil Dog: The Hound of Hell*.

Beast can be rather upsetting. Weird because, although we know the main lion is CGI, it was still distressing to see the lion being hurt in multiple different ways. I don't get upset during the movies mentioned above, so I think it boils down to I just really love cats. The film does bring a focus on poachers and the decimation of the wild animals in Africa. It's a serious problem and really, can you blame the animals for fighting back?

At no point does *Beast* hide what it wants to accomplish. They made a movie that stars an actor everyone loves and pits him against a bigass enraged lion. I mean, who doesn't want to see Idris Elba punching lions? In the end, does it really matter how good the movie is if the main objective is to see Elba literally fight a lion? The answer, for me anyway, is no.

★★ *— Sarah Jane*

ALAMO LAKELINE, ALAMO MUELLER, ALAMO SLAUGHTER LANE, AMC DINE-IN TECH RIDGE 10, BARTON CREEK SQUARE, CINEMARK 20, CM CEDAR PARK, CM HILL COUNTRY GALLERIA, CM STONE HILL TOWN CENTER, EVO CINEMAS BELTERRA, FLIX BREWHOUSE, HIGHLAND, GATEWAY, IPIC, LAKELINE, METROPOLITAN, MOVIEHOUSE, MOVIEHOUSE & EATERY LANTANA PLACE, LAKE CREEK 7, WESTGATE

ALAMO S. LAMAR, ARBOR, BARTON CREEK SQUARE, CINEMARK 20, IPIC, WESTGATE



Funny Pages

FUNNY PAGES

D: Owen Kline; with Daniel Zolghadri, Matthew Maher, Miles Emanuel, Michael Townsend Wright, Maria Dizzia, Josh Pais. (R, 87 min.)

Few films have the moxie to have their lead character be not simply flawed but remorselessly, consistently annoying: fewer still when that lead is arguably the closest thing to an immediately identifiable character. So it is with *Funny Pages* and its protagonist, Daniel Zolghadri as rising young artist Robert – rising right up his own ass, that is.

Although “protagonist” is the wrong word, because few characters are as quickly antagonizing as Robert. A talented illustrator with the wrong influences, he’s the kind of comic fan who’ll scoff at Marvel and DC while waxing lyrical about the linework in a Tijuana bible, or accuse his only friend, Miles (Emanuel), of ripping off *Beanworld*. Probably the only reason this slacker Holden Caulfield doesn’t call people “phonies” is because he’d think that was passé. He’s looking for some kind of artistic purity and he feels like he finds it in Wallace (Maher), a former color separator for Image Comics.

It’s a rare major part for veteran character actor Maher (most recently famous as Black Pete in *Our Flag Means Death*), who finally intrudes into the story once Robert has already impressively screwed up his life. Dysfunctional and deeply selfish, he’s simultaneously unwilling to have Robert’s puppy dog eyes on him and willing to take advantage of this misplaced hero worship. All the while, he’s the walking embodiment of the seething self-loathing that seeps through every frame.

First-time director Kline has an eye for the kind of faces that prior directors have spotted for how they embrace their bulbous, sagging, protruding weirdness: Like Stephen Adly Guirgis from Charlie Kaufman’s *Synecdoche, New York* and Todd Solondz’s *Palindromes*, as Robert’s high school art teacher, Mr. Katano, whose untimely death is what finally motivates his student to go off and embrace the whole “starving artist in a garret” myth. Only it’s not really a garret, but a converted boiler room in a basement in Trenton run as a sweaty doss-house by the friendly but creepy Barry (Wright), who sits around in his underwear watching movies that a friend has burned to CD-ROM for him.

It’s a de-romanticized version of another trip into underground comics, Terry Zwigoff’s oddly glossy 2001 adaptation of Daniel Clowes’ *Ghost*

World, in which Thora Birch’s studiously disaffected goth latches on to Steve Buscemi’s nerdy record collector. But there’s no gloss here as Kline revels in the gross physicality of his characters: Barry’s sweatiness, Miles’ acne, Wallace’s cleft lip, and the bedraggled Larry Fine *everything* of Mitchell Wenig (instantly recognizable as one of the debt-settling siblings from *Uncut Gems*, directed by producing duo the Safdie brothers).

It’s all deliberately grotesque, but comic readers will be pleasantly surprised at the degree of compassion for and comprehension of the culture Kline portrays. The circa millennium setting puts *Funny Pages* in that moment when a new snobbery was born around high-end reprints of alternative comics, while the selection of Image (always the industry’s “other guy”) and color separator (the lowest of the low) are Easter eggs that add richness to this tale of teen pomposity.

★★★

– Richard Whittaker

ALAMO S. LAMAR

OPENINGS

Breaking (PG-13)
Beast (R)
Funny Pages (R)
The Innocents (NR)
The Invitation (PG-13)
Liger (NR)
Maneater (R)
Spin Me Round (NR)
Three Thousand Years of Longing (R)
York Witches Society (R)

RATINGS

- ★★★★★ As perfect as a movie can be
- ★★★★ Slightly flawed, but excellent nonetheless
- ★★★ Has its good points, and its bad points
- ★★ Mediocre, but with one or two bright spots
- ★ Poor, without any saving graces
- La bomba
- ★ ★ Recommended



NORTH BY NORTHWEST



TOKYO STORY

PARAMOUNT
 SUMMER CLASSIC
 FILM SERIES

PRESENTED BY
 CapMetro

THURSDAY, AUGUST 25

Vertigo (7:30pm) (P)

SATURDAY, AUGUST 27

Rear Window (1pm) (P)

North by Northwest (4pm) (P)

SUNDAY, AUGUST 28

North by Northwest (1pm) (P)

Rear Window (4pm) (P)

TUESDAY, AUGUST 30

Tokyo Story (7pm) (P)

WEDNESDAY, AUGUST 31

The Good, the Bad, and the Ugly (7pm) (P)

THURSDAY, SEPTEMBER 1

Lawrence of Arabia (7pm) (P)

SATURDAY, SEPTEMBER 3

2001: A Space Odyssey (2pm) (P)

TICKETS: AUSTINTHEATRE.ORG/FILMS

(P) Paramount Theatre | 713 Congress Avenue
 (S) Stateside Theatre | 719 Congress Avenue

aGLIFF & The Austin Asian American Film Festival Invite You To Attend

Fragrance of the first Flower

Now that Taiwan has legalized same-sex marriage, will a closeted lesbian find the courage to admit her feelings?



文化局
 CULTURE BUREAU



Director Teng I-Han from Taiwan LIVE for a post-screening talkback

August 27 • 2:15 p.m. Galaxy Theatres Austin • 6800 Middle Fiskville Rd

Part of aGLIFF's PRISM 35 LGBTQ+ Film Festival August 24-28, 2022
 General Admission Tickets: \$15 + service fees at AGLIFF.ORG/PRISM

This screening made possible by the Taiwan Film and Audiovisual Institute and the Taiwan Academy of the Taipei Economic and Cultural Office in Houston.

☛ THE INNOCENTS

D: Eskil Vogt; with Raket Lenora Fløttum, Alva Brynsmo Ramstad, Sam Ashraf, Mina Yasmin Bremseth Asheim, Ellen Dorrit Petersen, Morten Svartveit. (NR, 118 min., subtitled)

This week, some Helen Lovejoy “won’t someone think of the children?” type decided to become Twitter’s lead character of the day by bemoaning millennials who don’t become parents. Why, he whined, would you possibly not want to have kids? Well, after watching Norwegian slow-burn horror *The Innocents*, the answer is clearly “to avoid being murdered by your superpowered bratlings.”

It does seem that, over the last few years, there’s been a substrand of Norwegian cinema reappraising the inherent menace of the superhero movie – indeed, of specific plotlines and tropes. In 2017, Joachim Trier took a grounded look at the terror a Phoenix-esque force would inflict in *The Irma*, while André Øvredal’s 2020 mythological thriller *Mortal* was a clear attempt to wrest Thor back from the clutches of Hollywood. Now *Blind* director, longtime Trier collaborator, and (far from coincidentally) *The Irma* writer Eskil Vogt seemingly deconstructs *The New Mutants* and its preadults with near-divine powers. The 2020 Fox adaptation of the Marvel comic missed the point by shoving them into a bad draft of *A Nightmare on Elm Street 3: Dream Warriors* rather than examining the inherent darkness of the comics: that a developing brain combined with godlike powers is a recipe for pure disaster.

The quartet of small gods in Vogt’s Norwegian suburb are interlinked through a pool of interacting powers: ESP, telekinesis, and mind control. Bonded together as a little gang, they’re an unlikely Fantastic Four. Anna (Ramstad) is quietly seething that she’s forced to look after her developmentally challenged elder sister (Fløttum), and falls in with Ben (Ashraf), a mean and lonely boy with a violent streak. The inherent hope is that his influence will be offset by Aisha (Asheim), who “hears” people even when they’re nowhere around.

Vogt brings out the ugliness of childhood (the shallow empathy, the lashing out, the selfishness, the curiosity about the disgusting) and ramps it up with endless malice that slowly builds to horrific action. It’s the anti-jump scare, with a sickening catharsis that what you think is coming does, indeed, come to pass. Moreover, he remembers that kids will always keep adults at arm’s length, especially when it comes to hiding their little crimes, and *The Innocents* always keeps the kids at the center. The only real disappointment is that it falls back on what’s becoming the dominant style in Scandinavian horror: handheld, in a slightly bleached-out day-time. That’s a shame considering that it’s Sturla Brandth Grøvlen behind the lens, and for both his one-shot masterpiece *Victoria* and black-and-white architectural study *Last and First Men* his cinematography was revelatory. Here it at

least gives a grounded background that makes the ensuing battle between pint-sized good and miniature malevolence both epic in threat and intimate in delivery.

★★★

– Richard Whittaker
AFS CINEMA

THE INVITATION

D: Jessica M. Thompson; with Courtney Taylor, Nathalie Emmanuel, Thomas Doherty, Hugh Skinner, Sean Pertwee. (PG-13, 104 min.)

Not reviewed at press time. Family reunion goes awry in this gothish horror.

ALAMO LAKELINE, AMC DINE-IN TECH RIDGE 10, BARTON CREEK SQUARE, CINEMARK 20, CM CEDAR PARK, CM HILL COUNTRY GALLERIA, CM STONE HILL TOWN CENTER, EVO CINEMAS BELTERRA, FLIX BREWHOUSE, HIGHLAND, GATEWAY, IPIC, LAKELINE, METROPOLITAN, WESTGATE

LIGER

D: Puri Jagannadh; with Vijay Deverakonda, Ananya Panday, Ramya Krishnan, Ronit Roy. (NR, 130 min., subtitled)

Not reviewed at press time. Vijay Deverakonda plays a kickboxer in this hard-hitting sports drama.

CINEMARK 20, CM CEDAR PARK, CM HILL COUNTRY GALLERIA

SPIN ME ROUND

D: Jeff Baena; with Alison Brie, Aubrey Plaza, Alessandro Nivola, Molly Shannon, Tim Heidecker, Zach Woods, Fred Armisen, Debby Ryan, Lil Rel Howery. (NR, 104 min.)

Consider *Ocean’s 11*. The Rat Pack original, not the far better Steven Soderbergh remake. It was less a movie and more of an excuse for Frank Sinatra and his pals to hang out in Las Vegas and get paid to do it (several of the crew were actually pulling double duty, doing casino shows at night and filming in the day). As the saying goes, nice work if you can get it, and there’s a sneaking suspicion that Jeff Baena pulled a similar trick with *Spin Me Round*, a shapeless satire that seems like a decent reason to spend a few weeks in Italy with some pals.

Having assembled a troupe of regulars through his career (Aubrey Plaza and Molly Shannon in horror tragicomedy *Life After Beth*, Alison Brie with *Joshy*, Fred Armisen to the mix in Boccaccio spoof *The Little Hours*, and Debby Ryan for *Horse Girl*) and the gang’s all here for *Spin Me Round*, and hopefully the ensemble enjoyed the filmmaking process, as the end result is an odd, laughless, meandering comedy that’s not entertaining enough to be engaging or gifted with enough character insight to justify its aimless length.

Brie plays Amber, a disaffected and downtrodden manager at a Macaroni Grill-esque chain called Tuscan Grove who wins a competition to fly to Italy on the company’s dime. Bafflingly moonstruck over founder Nick (Nivola), she flirts with the idea of being whisked off her feet by the family-sized-serving pasta tycoon. Mooning like a dime-store novel teen heroine – a character beat at odds with the world-weary thirty-something glimpsed in the opening montages – she giddily engages in a surprisingly chaste

tryst on his yacht, bafflingly oblivious to the obvious reality that she’s nothing more than a notch in his mizzenmast.

It’s hard to engage when the rest of the cast is working with the thinnest of character outlines: overextended cameos that vary between grating and wasted potential. But then this is the shaded outline of a film, as if the cast is trying to work in broad strokes while still underplaying, like they’re in the first stages of rehearsal. Amber is likable but intolerably stupid, jumping through rom-com clichés that seem completely at odds with whatever points Baena is trying to make about trying to live the *Eat Pray Love* life in the real world. Everything is thrown into the grinder of a ridiculous final act that shreds any subtextual nuance about workplace power dynamics, sexual antics, and blind romance. After floundering around, unsure of its exact tone, *Spin Me Round* seems to settle on some kind of Blake Edwards-lite farce, but devoid of any gusto.

★★

– Richard Whittaker
AFS CINEMA

THREE THOUSAND YEARS OF LONGING

D: George Miller; with Tilda Swinton, Idris Elba. (R, 108 min.)

With a title like *Three Thousand Years of Longing*, George Miller’s highly anticipated follow-up to the blockbuster hit *Mad Max: Fury Road* sounds like it should be a hot and sweltering epic romance to end the summer on, some good, classic, high-octane fun before the fall hits us with awards season fare. Starring powerhouses like Tilda Swinton and Idris Elba, you’d expect nothing less. Instead, Miller’s latest feels like a film that’s been waiting to be released since the late 2000s, a CGI-driven adventure that zooms through time and space with wannabe Tarsem Singh visuals and an overstuffed story that is never given room to breathe.

Three Thousand Years of Longing is one *Thousand and One Nights* lite. Swinton plays a character of solitude, Alithea: a divorcée who enjoys academia and travel. While on a trip to Istanbul, she finds a strange glass object in an eclectic antique shop and an urge overcomes her to purchase it, not knowing that a djinn (Elba) resides in its depths, patiently waiting to be

released. Alithea eventually does just that in the comfort of her hotel room – after she accidentally breaks the glass bottle while cleaning it, Elba’s muscular body bursts into the hotel room, all electricity and abs, and thus their story begins.

The first half of the movie focuses on the djinn’s journey: He tells three tall tales selected to unleash desire within Alithea, create a yearning so powerful that she uses the three wishes she has been given wisely, so he can move on from his prison. Alithea’s yearning, though, is difficult to connect with. Miller’s speedy pacing and off-putting use of humor create a mixed bag, leaving each story less satisfying than the one before it. Neither sweeping nor enchanting, the djinn’s choppy lifelong lessons feel shallow and dull (not to mention, the djinn’s second tale is chock-full of fatphobia, which is a disappointment to say the least).

Yet, somehow, Alithea becomes transfixed by the djinn, and the second half of the movie turns into a soft romance between the two. She delights in learning about her new lover, but always ponders if his feelings are genuine (she does, after all, use one of her wishes to make him reciprocate her yearning). The contrast in the tonal shift is bold, but jarring – suddenly Miller’s film feels like an entirely new beast. Miller’s own storytelling is as sloppy as the djinn’s, and the longing he so wishes for us to partake in feels forced, unearned, and alienating. Where *Mad Max: Fury Road* was lean, *Three Thousand Years of Longing* feels like a rough draft that should have stayed in a dusty bin somewhere in the middle of a tourist shop.

★★

– Jenny Nulf

ALAMO LAKELINE, ALAMO MUELLER, ALAMO SLAUGHTER LANE, ALAMO S. LAMAR, ALAMO VILLAGE, AMC DINE-IN TECH RIDGE 10, ARBOR, BARTON CREEK SQUARE, CINEMARK 20, CM CEDAR PARK, CM HILL COUNTRY GALLERIA, CM STONE HILL TOWN CENTER, EVO CINEMAS BELTERRA, FLIX BREWHOUSE, HIGHLAND, GATEWAY, IPIC, LAKELINE, METROPOLITAN, MOVIEHOUSE, MOVIEHOUSE & EATERY LANTANA PLACE, LAKE CREEK 7, WESTGATE

YORK WITCHES SOCIETY

D: Liza Bolton; with Georgia Lock, Rachel Warren, Sydney Craven, Finbar Lynch, Sophie Bloor. (R, 88 min.)

Not reviewed at press time. Evil hunts a coven of upper-class British witches.

HIGHLAND



Three Thousand Years of Longing

ALAMO DRAFTHOUSE
PRESENTS

FANTASTIC FEST²²

SEPTEMBER 22 - 29



TRIANGLE
OF SADNESS

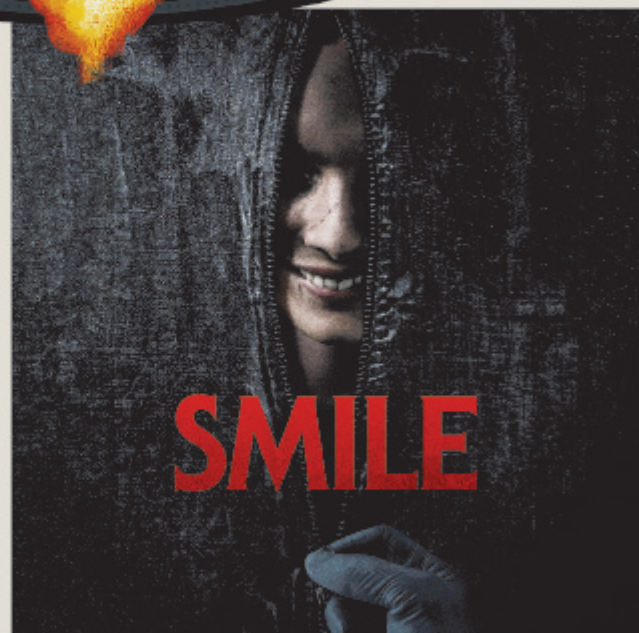

SMILE

THE ONLY FILM FEST WEIRD ENOUGH FOR AUSTIN, TX RETURNS
8 DAYS. 80 FILMS. WORLD PREMIERES. EPIC PARTIES. WILD FUN.

BADGES ON SALE NOW @ FANTASTICFEST.COM

SPECIAL SCREENINGS

BY KAT McNEVINS



Drunken Master II

BACK TO THE NINETIES

Dazed and Confused (1993) D: Richard Linklater; with Jason London, Wiley Wiggins, Rory Cochrane, Matthew McConaughey. (R, 103 min.) **Beer Dinner.** Party at the moon tower! Beer goes so well with bongs and bell-bottoms. (*) @Flix Brehouse, Tue., Aug. 30, 7pm.

Drunken Master II (1994) D: Lau Kar-leung and Jackie Chan. (R, 99 min.) **Fist City.** The film that cemented Chan's iconic action hero status. (*) @Alamo Village, Sun., Aug. 28, 4:35, 7:30pm. @Alamo Slaughter Lane, Tue., Aug. 30, 7:40pm.

The Hole (1998) D: Tsai Ming-liang; with Yang Kuei-mei, Lee Kang-sheng, Tien Miao. (NR, 95 min., subtitled) **Lates.** A sci-fi musical from the director of *Goodbye, Dragon Inn* that the *Chronicle* called "broodingly apocalyptic and thoroughly original." @AFS Cinema, Fri.-Sat., Aug. 26-27, 9:45pm; Mon., Aug. 29, 7pm.

Irma Vep (1996) D: Olivier Assayas; with Maggie Cheung, Jean-Pierre Léaud, Nathalie Richard. (NR, 96 min., subtitled) **World Cinema Classics.** Alicia Vikander starred in a recent HBO series based on this French drama about film-making that the *Chronicle* called "bizarre and beautiful" in 1997. (*) @AFS Cinema, Sat., Aug. 27, 7:15pm; Sun., Aug. 28, 4:30pm; Tue., Aug. 30, 7pm.

Only Yesterday (1991) D: Isao Takahata. (NR, 118 min., subtitled) **Fathom Events.** While traveling from Tokyo to visit family, a woman takes another trip down memory lane and revisits childhood dreams. Screening as part of Studio Ghibli Fest. (*) @Gateway, Arbor, Sun., Aug. 28, 3, 7pm; Mon., Aug. 29, 7pm. @Violet Crown, Sun., Aug. 28, 3pm; Mon., Aug. 29, 7pm.

Wigstock: The Movie (1995) D: Barry Shils. (NR, 85 min.) **Queer Cinema: Lost & Found.** A doc capturing New York's iconic celebration of peace, love, and big hair, featuring performances by icons like the "Lady" Bunny, RuPaul, Leigh Bowery, Lypsinka, and more. Queer film historian and programmer Elizabeth Purchell moderates a virtual director Q&A after the Friday screening; for more on Purchell, see p.26. @AFS Cinema, Fri. & Wed., Aug. 26 & 31, 7pm.

FEATURED SCREENINGS

American Graffiti (1973) D: George Lucas; with Richard Dreyfuss. (PG, 110 min.) **Flashback Cinema.** @Pic, Sun., Aug. 28, 3pm; Wed., Aug. 31, 7:45pm. @Highland, Sun., Aug. 28, 7:40pm; Wed., Aug. 31, 1, 7pm.

Apocalypse Now: Final Cut (1979) D: Francis Ford Coppola; with Marlon Brando, Martin Sheen, Robert Duvall. (R, 182 min.) **R&R: Remastered & Restored.** Coppola's surreal Vietnam War epic was restored to the director's "perfect vision" for its 40th anniversary. @Alamo Village, Lakeline; find showtimes online.

Be Pretty and Shut Up! (1981) D: Delphine Seyrig. (NR, 115 min.) **Essential Cinema.** Two dozen actresses – Jane Fonda, Ellen Burstyn, Shirley MacLaine, to name a few – are interviewed about their experiences in the film industry. @AFS Cinema, Thu., Aug. 25, 7:30pm; Sat., Aug. 27, 4:45pm.

"The Boy From Hell" (2004) D: Mari Asato. (R, 50 min., subtitled) **Terror Tuesday.** The stylish J-horror screens with two underground short films. @Alamo S. Lamar, Tue., Aug. 30, 9:30pm.

Class of 1984 (1982) D: Mark L. Lester; with Perry King, Merrie Lynn Ross, Timothy Van Patten. (R, 98 min.) **R&R: Remastered & Restored.** A novice teacher takes matters into his own hands when a pack of teen ruffians sets out on a reign of terror. @Alamo Village, Tue., Aug. 30, 7:30pm.



Wigstock: The Movie

Fitzcarraldo (1982) D: Werner Herzog; with Klaus Kinski, Claudia Cardinale. (PG, 158 min., subtitled) Fitzcarraldo (Kinski) aspires to build an opera house in the Peruvian jungle. @Alamo S. Lamar, Sun., Aug. 28, 5:45pm; Wed., Aug. 31, 6:30pm.

Galaxy Quest and Dark Star A double feature of the 1999 sci-fi comedy and the 1974 John Carpenter cult classic. @Blue Starlite Mueller II, Fri.-Sat., Aug. 26-27, 8:30pm.

The Good, the Bad and the Ugly (1966) D: Sergio Leone; with Clint Eastwood. (R, 176 min.) **Paramount Summer Classic Film Series.** As summer draws to a close, the series concludes with an "Epic Finish," featuring films that all clock in at around three hours but are worth every minute. @Paramount Theatre, Wed., Aug. 31, 7pm.

Goosebumps (2015) D: Rob Letterman; with Jack Black, Dylan Minnette. (PG, 103 min.) **Kids Camp.** The beloved R.L. Stine book series comes to life as a teen (Minnette) meets his next-door neighbor, whose dad turns out to be Stine himself (Black). (*) @Alamo Lakeline, Mueller, Slaughter Lane; find showtimes online.

Hard Rock Zombies (1985) D: Krishna Shah; with E.J. Curse, Jennifer Coe, Jack Bliesener. (R, 98 min.) **Andy's Di\$count \$inema.** Out of the grave and onto the stage, the undead give the performance of a lifetime. Preceded by short film "Cold Blooded" by local director Kidd Tommy. Vendors will bring VHS tapes for a tailgate party, and guests are encouraged to don heavy metal looks and bring tapes of their own. @Blue Starlite Mueller II, Wed., Aug. 31, 8:45pm.

The Innocents (2021) D: Eskil Vogt; with Rakei Lenora Fløttum, Alva Brynsmo Ramstad, Sam Ashraf. (NR, 117 min., subtitled) **Modern Masters.** A brilliant follow-up to *Blind*, about a group of kids exploring their dark powers during a bright Nordic summer. @AFS Cinema, Sat., Aug. 27, 2pm; Sun., Aug. 28, 7pm; Wed., Aug. 31, 9pm.

The Invisible Man (2020) D: Leigh Whannell; with Elisabeth Moss. (R, 110 min.) Moss is riveting as an abuse survivor tormented by her ex from beyond the grave. (*) @Doc's Drive In, Thu., Aug. 25, 10:50pm.

Lawrence of Arabia (1962) D: David Lean; with Peter O'Toole, Omar Sharif, Alec Guinness, Anthony Quinn. (PG, 216 min.) **Paramount Summer Classic Film Series: Epic Finish.** @Paramount Theatre, Thu., Sept. 1, 7pm.

A Man Called Adam (1966) D: Leo Penn. (NR, 104 min.) **Newly Restored.** A gritty portrait of a self-destructive jazz trumpeter. @AFS Cinema, Sun., Aug. 28, 2pm.

Mija (2022) D: Isabel Castro. (NR, 85 min.) **CineNoche.** Cine Las Americas presents a screening of a doc chronicling the emotional and complex stories of two daughters of undocumented immigrants as they navigate music careers. @Violet Crown, Wed., Aug. 31, 7pm.

North by Northwest (1959) D: Alfred Hitchcock; with Cary Grant, Eva Marie Saint, James Mason. (NR, 136 min.) **Paramount Summer Classic Film Series.** Hitchcock Week concludes with two of the best, and you can catch a double feature with *Rear Window* Saturday and Sunday. @Paramount Theatre, Sat., Aug. 27, 4pm; Sun., Aug. 28, 1pm.

Rear Window (1954) D: Alfred Hitchcock; with James Stewart, Grace Kelly. (PG, 114 min.) **Paramount Summer Classic Film Series.** @Paramount Theatre, Sat., Aug. 27, 1pm; Sun., Aug. 28, 4:30pm.

Rebel Without a Cause (1955) D: Nicholas Ray; with James Dean, Natalie Wood. (NR, 111 min.) **Essential Cinema.** Screening as part of a series called "Natalie Wood: It's in the Eyes." @AFS Cinema, Thu., Sept. 1, 7:30pm.

Rogue One: A Star Wars Story (2016) D: Gareth Edwards; with Felicity Jones, Diego Luna. (PG-13, 133 min.) An exclusive Imax re-release for one week only, with additional footage and a sneak peek of Disney+ Star Wars series *Andor*. (*) @Bullock Texas State History Museum, Fri.-Sun. & Wed., Aug. 26-28 & 31, 4, 7:30pm.

Secret Celluloid Mystery Movie Weird Wednesday. They're keeping mum on the title, but promise martial arts mayhem that'll knock your socks off. @Alamo S. Lamar, Wed., Aug. 31, 9:30pm.

Taxi Driver (1976) D: Martin Scorsese; with Robert De Niro, Jodie Foster. (R, 113 min.) **Big Screen Classics.** Don't miss your chance to see this one in the theatre. @AFS Cinema, Sat., Aug. 27, 4:15pm.

They Live (1988) D: John Carpenter; with Roddy Piper, Keith David, Meg Foster. (R, 97 min.) **Summer of Darkness.** The classic sci-fi satire closes out the summer-long Carpenter retrospective. @Alamo Village, Slaughter Lane, Lakeline; find showtimes online.

Tokyo Story (1953) D: Yasujiro Ozu; with Chishū Ryū, Chieko Higashiyama, Setsuko Hara, Haruko Sugimura. (NR, 136 min., subtitled) **Paramount Summer Classic Film Series.** BFI's *Sight and Sound* magazine asked the greatest living directors what their favorite movie was, and this was their choice. @Paramount Theatre, Tue., Aug. 30, 7pm.

SPACES

Encanto (2021) D: Jared Bush, Byron Howard and Charise Castro Smith. (PG, 99 min.) **Movies in the Park.** Dogs, picnics, and lawn chairs are welcome at this screening (en español) put on by the Austin Parks Foundation. (*) @Dove Springs Park, Fri., Sept. 9, 8:30pm.

Sonic the Hedgehog 2 (2022) D: Jeff Fowler. (PG, 122 min.) Bring chairs or a blanket for a fam-friendly amphitheatre screening. (*) @Community First! Village, Fri., Aug. 26, 7:30pm.

Michel Gondry Night A very cool evening of Gondry's surreal and innovative visuals, including music videos like Daft Punk's "Around the World," short films, and commercials, and maybe even some special requests. @Dimension Gallery, Sat., Aug. 27, 8:30pm.

Blood for Dracula (1974) D: Paul Morrissey. (R, 106 min.) **Hyperreal Hotel.** The Warhol/Morrissey indie horror screens with a local short film as part of the birthday bash for the Velvet Underground's Sterling Morrison. @Hotel Vegas, Mon., Aug. 29, 6:30pm.

Can't Hardly Wait (1998) D: Harry Elfont and Deborah Kaplan; with Jennifer Love Hewitt, Ethan Embry, Seth Green. (PG-13, 101 min.) **Movie Massacre.** There'll be a raffle, a VHS buy/sell/trade, and fun facts and insight before the Nineties comedy about a raucous high school graduation party. (*) @The Ballroom, Mon., Aug. 29, 8pm.

Grease Sing-Along (1978) D: Randall Kleiser; with John Travolta, Olivia Newton-John. (PG, 112 min.) **Waterfront Floating Cinema.** In an all-new experience offered by Blue Starlite, you'll float on a waterfront platform at Lady Bird Lake with the city behind you and a 20-foot screen in front of you, and those with their own vessels can boat in to the movies! @Capital Cruises, Thu., Sept. 1, 9:30pm.

FESTIVALS

aGLIFF: Prism 35 The 35th annual marquee LGBTQ+ film festival presents four days in person, then most of the films will be available virtually. @Highland, Aug. 24-28; virtual option Aug. 29-Sept. 5. aglif.org.

Front Festival Film Showcase The lineup includes 11 shorts from Texas artists and directors, with featured screenings of "But Humble Sinners" and "Moondogs," plus a panel on creative storytelling, music, pop-ups, and more. @The Contemporary Austin at Laguna Gloria, Sat., Aug. 27, 7pm.

High Contrast: A Neon Noir Film Series Violet Crown presents five films that "pull film noir out of the shadows and into the bright neon of their urban settings while adding some cool music to boot." @Violet Crown, Sept. 1, 8 & 22, 7pm.

THE SYMBOL (*) INDICATES FULL-LENGTH REVIEWS AVAILABLE ONLINE: AUSTINCHRONICLE.COM/FILM

SUBMISSION INFORMATION: *The Austin Chronicle* is published every Thursday. Info is due the Monday of the week prior to the issue date. **The deadline for the Sept. 9 issue is Monday, Aug. 29.** Include name of event, date, time, location, price, phone number(s), a description, and any available photos or artwork. Send submissions to the *Chronicle*, PO Box 4189, Austin, TX 78765; fax, 512/458-6910; or email. Contact Kat McNevins (Special Screenings): specialscreenings@austinchronicle.com.



Looking for showtimes?

To find up-to-date times searchable by movie title, theatre, and date, scan this QR code or go to austinchronicle.com/film.

FIRST RUNS

Full-length reviews available online at austinchronicle.com/events/film.

★ The Black Phone ★★★★★

D: Scott Derrickson. (R, 102 min.) Ethan Hawke is a villain for the ages in this brilliant horror. METROPOLITAN

★ Bodies Bodies Bodies ★★★★★

D: Halina Reijn. (R, 95 min.) Killer cast cuts to the core in this self-aware Gen Z *Clue* riff.

ALAMO LAKELINE, ALAMO MUELLER, ALAMO SLAUGHTER LANE, ALAMO S. LAMAR, BARTON CREEK SQUARE, BLUE STARLITE MUELLER II, CINEMARK 20, EVO CINEMAS BELTERRA, IPIC, VIOLET CROWN, WESTGATE

★ Bullet Train ★★★★★

D: David Leitch. (R, 126 min.) Brad Pitt bumbles entertainingly through a hyperviolent slapstick comedy.

ALAMO LAKELINE, ALAMO MUELLER, ALAMO SLAUGHTER LANE, ALAMO S. LAMAR, ALAMO VILLAGE, AMC DINE-IN TECH RIDGE 10, BARTON CREEK SQUARE, CINEMARK 20, CM CEDAR PARK, CM HILL COUNTRY GALLERIA, CM STONE HILL TOWN CENTER, EVO CINEMAS BELTERRA, FLIX BREWHOUSE, HIGHLAND, GATEWAY, IPIC, LAKELINE, METROPOLITAN, MOVIEHOUSE, MOVIEHOUSE & EATERY LANTANA PLACE, LAKE CREEK 7, VIOLET CROWN, WESTGATE

★ DC League of Super-Pets ★★★★★

D: Jared Stern, Sam Levine. (PG, 106 min.) Fuzzy superhero antics are perfect summery kids' fare.

ALAMO LAKELINE, ALAMO SLAUGHTER LANE, AMC DINE-IN TECH RIDGE 10, BARTON CREEK SQUARE, CINEMARK 20, CM CEDAR PARK, CM HILL COUNTRY GALLERIA, CM STONE HILL TOWN CENTER, EVO CINEMAS BELTERRA, FLIX BREWHOUSE, HIGHLAND, GATEWAY, IPIC, LAKELINE, METROPOLITAN, MOVIEHOUSE, MOVIEHOUSE & EATERY LANTANA PLACE, LAKE CREEK 7, WESTGATE

★ Deep in the Heart ★★★★★

D: Ben Masters. (NR, 90 min.) Texas' diverse and precious wildlife gets the documentary it deserves. AFS CINEMA

★ Dragon Ball Super: Super Hero ★★★★★

D: Tetsuro Kodama. (PG-13, 100 min., subtitled) An old adversary spices up an otherwise very *Dragon Ball*-y flick.

ALAMO LAKELINE, ALAMO MUELLER, ALAMO SLAUGHTER LANE, ALAMO S. LAMAR, AMC DINE-IN TECH RIDGE 10, ARBOR, BARTON CREEK SQUARE, CINEMARK 20, CM CEDAR PARK, CM HILL COUNTRY GALLERIA, CM STONE HILL TOWN CENTER, EVO CINEMAS BELTERRA, FLIX BREWHOUSE, HIGHLAND, GATEWAY, IPIC, LAKELINE, METROPOLITAN, MOVIEHOUSE, MOVIEHOUSE & EATERY LANTANA PLACE, LAKE CREEK 7, WESTGATE

★ Elvis ★★★★★

D: Baz Luhrmann. (PG-13, 159 min.) If you're looking for trouble (and an exhaustive, overblown, and detailed yet fantastical biopic of the King of Rock and Roll), you came to the right place.

ALAMO LAKELINE, AMC DINE-IN TECH RIDGE 10, ARBOR, BARTON CREEK SQUARE, CINEMARK 20, CM CEDAR PARK, CM HILL COUNTRY GALLERIA, EVO CINEMAS BELTERRA, GATEWAY, LAKELINE, MOVIEHOUSE, MOVIEHOUSE & EATERY LANTANA PLACE

★ Emily the Criminal ★★★★★

D: John Patton Ford. (R, 93 min.) Aubrey Plaza goes from wage slave to independent crook in this critique of capitalism.

AMC DINE-IN TECH RIDGE 10, ARBOR, BARTON CREEK SQUARE, VIOLET CROWN

★ Everything Everywhere All at Once ★★★★★

D: Daniel Kwan, Daniel Scheinert. (R, 140 min.) Michelle Yeoh leaps into the multiverse in this incredible, inventive comedy. BLUE STARLITE MUELLER II

★ Facing Nolan ★★★★★

D: Bradley Jackson. (NR, 102 min.) The life of baseball's (fairly) scandal-free hall of famer.

MOVIEHOUSE, MOVIEHOUSE & EATERY LANTANA PLACE

Fall ★★★

D: Scott Mann. (PG-13, 107 min.) It's a great view in this vertigo-inducing survival thriller. CINEMARK 20, CM CEDAR PARK

★ Fire of Love ★★★★★

D: Sara Dosa. (PG, 97 min.) Fascinating true romance in the shadows of the burning Earth. AFS CINEMA

★ Jurassic World Dominion ★★★★★

D: Colin Trevorrow; with Sam Neill, Laura Dern, Jeff Goldblum, Chris Pratt, Bryce Dallas Howard, DeWanda Wise. (PG-13, 146 min.) Nothing new in the DNA of this dinosaur trilogy capper.

ALAMO LAKELINE, BARTON CREEK SQUARE, CINEMARK 20, CM CEDAR PARK, CM HILL COUNTRY GALLERIA, GATEWAY, LAKELINE

★ A Love Song ★★★★★

D: Max Walker-Silverman; with Dale Dickey, Wes Studi, Michelle Wilson, Benja K. Thomas. (PG, 81 min.) Dale Dickey paints a meticulous portrait of a woman coming to terms with love. ARBOR

★ Mad God ★★★★★

D: Phil Tippett. (NR, 85 min.) Phil Tippett's stop motion masterpiece of depravity and the divine. BLUE STARLITE MUELLER II

★ Marcel the Shell With Shoes On ★★★★★

D: Dean Fleischer-Camp. (PG, 89 min.) Sweet and funny story of a talking shell will fill your heart.

ALAMO S. LAMAR, BLUE STARLITE MUELLER II

★ Minions: The Rise of Gru ★★★★★

D: Kyle Balda. (PG, 87 min.) Kevin, Stuart, yee Bob nama bok, yee ba veela doegab tadtee de Otto!

AMC DINE-IN TECH RIDGE 10, BARTON CREEK SQUARE, BLUE STARLITE DOWNTOWN, CINEMARK 20, CM CEDAR PARK, CM HILL COUNTRY GALLERIA, CM STONE HILL TOWN CENTER, EVO CINEMAS BELTERRA, GATEWAY, LAKELINE, WESTGATE

★ Mrs. Harris Goes to Paris ★★★★★

D: Anthony Fabian. (PG, 115 min.) All eyes on Lesley Manville in this tale of fashion and grit. ARBOR

★ Nope ★★★★★

D: Jordan Peele. (R, 131 min.) Jordan Peele's sci-fi horror/satire on minor celebrity is more of a "yeah."

ALAMO LAKELINE, ALAMO MUELLER, ALAMO SLAUGHTER LANE, ALAMO S. LAMAR, ALAMO VILLAGE, AMC DINE-IN TECH RIDGE 10, BARTON CREEK SQUARE, BLUE STARLITE DOWNTOWN, CINEMARK 20, CM CEDAR PARK, FLIX BREWHOUSE, GATEWAY, IPIC, METROPOLITAN, LAKE CREEK 7, WESTGATE

★ Orphan: First Kill ★★★★★

D: William Brent Bell. (R, 98 min.) The cuckoo's nest classic gets a gruesome and surprising prequel. HIGHLAND, GATEWAY

★ RRR ★★★★★

D: S.S. Rajamouli. (PG-13, 186 min., subtitled) Tollywood historical epic is bromantic action nirvana. BLUE STARLITE DOWNTOWN

★ The Territory ★★★★★

D: Alex Pritz. (PG, 83 min.) Inside the war to save the Amazon and its Indigenous peoples. BARTON CREEK SQUARE, MOVIEHOUSE

★ Thor: Love and Thunder ★★★★★

D: Taika Waititi. (PG-13, 118 min.) The Slayer of Thanos becomes a lovesick clown in this mirthless sequel.

ALAMO LAKELINE, ALAMO MUELLER, AMC DINE-IN TECH RIDGE 10, BARTON CREEK SQUARE, CINEMARK 20, CM CEDAR PARK, CM HILL COUNTRY GALLERIA, CM STONE HILL TOWN CENTER, EVO CINEMAS BELTERRA, FLIX BREWHOUSE, GATEWAY, LAKELINE, METROPOLITAN, MOVIEHOUSE, LAKE CREEK 7, WESTGATE

★ Top Gun: Maverick ★★★★★

D: Joseph Kosinski. (PG-13, 131 min.) Tom Cruise proves he's the last of his kind in this legacy sequel to his 1986 recruitment poster movie.

ALAMO LAKELINE, ALAMO S. LAMAR, AMC DINE-IN TECH RIDGE 10, BARTON CREEK SQUARE, CINEMARK 20, CM CEDAR PARK, CM HILL COUNTRY GALLERIA, CM STONE HILL TOWN CENTER, EVO CINEMAS BELTERRA, FLIX BREWHOUSE, GATEWAY, IPIC, LAKELINE, MOVIEHOUSE, MOVIEHOUSE & EATERY LANTANA PLACE, LAKE CREEK 7, WESTGATE

★ Vengeance ★★★★★

D: B.J. Novak. (R, 94 min.) B.J. Novak's directorial debut is a strange and touching tale of truth, myths, and Texas.

ALAMO SLAUGHTER LANE, ALAMO S. LAMAR, ARBOR, CM HILL COUNTRY GALLERIA, VIOLET CROWN

★ Where the Crawdads Sing ★★★★★

D: Olivia Newman. (PG-13, 125 min.) Cardboard characters get soggy in this swampy melodrama.

ARBOR, CM HILL COUNTRY GALLERIA, EVO CINEMAS BELTERRA, GATEWAY, MOVIEHOUSE, MOVIEHOUSE & EATERY LANTANA PLACE, WESTGATE

Last Saturday



Saturday, August 27
5 PM



Oasis Texas
Brewing Co.

THE AUSTIN
CHRONICLE

Your free,
independent news
source since 1981



MENTION
PROMO
CODE
IFS99

the LASH
LOUNGE

Beauty Without
the Hassle

GET YOUR FIRST FULL SET FOR JUST \$99!

THE LASH LOUNGE
AUSTIN - MUELLER

512.648.5274

AUSTIN - WEST LAKE HILLS

512.361.5274

CEDAR PARK - 1890 RANCH

512.817.2848

THELASHLOUNGE.COM

FOLLOW US ON SOCIAL MEDIA

@THELASHLOUNGEAUSTIN

Casa
Garcia's
Mexican Restaurant
& Cantina



Home of the Best Mexican and
Tex-Mex food, homemade
tortillas, and awesome margaritas!

CASAGARCIA.COM

1901 W. William Cannon • Austin, TX 78745

15803 Windermere Drive • Pflugerville, TX 78660

1691 State Hwy 46W, Ste 335 • New Braunfels, TX 78132

1901 N. IH-35 • Round Rock, TX 78664

12700 Lexington • Manor, TX 78653

5401 S. FM 1626 • Kyle, TX 78640

See austinchronicle.com/film for the complete list of films playing now.

Food

Restaurant Review: Hildee's Texas Dine-Inn

Ryan Hildebrand's Hill Country bistro has its ups and downs

BY MELANIE HAUPT

Chef Ryan Hildebrand, founder and former chef at Houston's FM Kitchen & Bar and erstwhile fine dining outfit Trinita, moved to Wimberley in 2019 and shortly afterward announced he'd be opening a "Hill Country bistro" adjacent to Blue Hole. One pandemic later, Hildee's Texas Dine-Inn opened its doors on March 31 of this year. The space, a modern barn with covered patio and indoor dining, was designed by Austin's Maker Architects and is simultaneously nostalgic and of the moment. The same is also true of the menu, which privileges seasonal Texas ingredients and weds traditional dishes with contemporary sensibilities.

Our first visit to Hildee's was for Sunday brunch. We're not ones for Sunday drives, but it was kind of fun to ramble through ranch roads flanked by land that hasn't been developed ... yet. In fact, I might have started yell-singing, "Country roaaaaads, take me hooooooooome," much to the annoyance of my fellow travelers, until we passed an Amazon fulfillment center. That shut me up right quick.

After about 45 minutes, we reached our destination, a shiny new red barn with an adjacent silver silo (it's unclear what the silo is for). We arrived not too long after Hildee's opened for brunch, so we were seated indoors right away. Several minutes and some pointed eye contact with staff transpired before our server greeted us, but she was quite attentive from that point forward. I ordered a mimosa, because brunch, which arrived with several edible flowers floating in it, which was puzzling. Was I supposed to drink them along with the mimosa? In general, I don't think mimosas need any garnish; I *really* don't think they need to have a nosegay floating in them.

The cornbread and pimento cheese were a kicky start to our meal; the tidy muffins flecked with jalapeño were a perfect complement to the creamy pimento cheese. The teen, whose primary food groups are bread and cheese, ordered the buttermilk pancakes, which arrived in a thick, fluffy tower of three topped with a huge dollop of cinnamon butter and a generous portion of mixed berries. While the cakes claim to be buttermilk, they bore an earthy, almost gingerbreadlike flavor while also being quite sweet. The generous portion meant that they made for great leftovers.

I selected the fried chicken-thigh biscuit sandwich, which tasted fine but was a little off-putting in texture. The thigh was a little too thick and fatty, and the pickles didn't provide enough acid to cut the fat. I also ordered a side of grits, which were subtly flavored, creamy, coarsely ground, and candy hued. My spouse's breakfast plate came

with two eggs over medium (as requested, and it's a rare thing to have that request met), two links of truly excellent sausage, skillet potatoes, and a big, fluffy biscuit (served hot, which gets a gold star from me).

While our brunch experience was generally pleasant, our return visit for a Friday night dinner was decidedly more uneven and somewhat disappointing.

When we arrived, our party of four was seated outside at a picnic table, where we sat unnoticed for at least 10 minutes. I had a fond recollection of the Mule Skinner Blue cocktail (an iteration of the Moscow mule with muddled blueberries) at a pre-view dinner in March, so I ordered one for an aperitif. It didn't quite live up to my memory of it, as the ginger beer didn't have



Hildee's Bars

PHOTOS COURTESY OF OVERWATCH PRODUCTIONS

much of a bite, the sparkling water seemed flat, and the fresh blueberries appeared to have been replaced by syrup.

For starters, we ordered the fried green tomatoes; sadly, the brisket burnt end rangons weren't available, so we opted for the wings with Valentina sauce. The fried green tomatoes, served with shredded pork between them, were soggy and got lost in the fatty meat. The accompanying caramelized cubes of beet and butternut squash, while out of season, were yummy little jewels, though. While the wings were both baked and fried, they did not deliver on the promise of crispiness, although they were delicious and disappeared rather quickly.

If the starter course was a little wobbly, the entrées are where this meal really went off the rails. One of my companions ordered the pork belly special, served with blue corn grits, a small garnish of bitter greens, and a blackberry barbecue sauce. The belly was soft and unctuous, but the skin was incredibly hard and difficult to eat; not quite the caramelized, porky candy you hope to encounter with pork belly. However, when the belly was combined with the bitter greens and the blackberry sauce, the flavors sang.

I was extremely disappointed when my smoked chicken arrived. I'd noticed on the menu that most of the other mains included a side, but the half chicken, at \$21, included a "parsley salad." Reader, it was not a salad. It was a few sprigs of parsley on top of half a roasted lemon. It would have been really nice

to have a few green beans or a wedge or two of potato to accompany the chicken, something to dance with the lemon jus in the bowl and break up the monotony of the salty meat.

My spouse was equally disappointed in his Hill Country Cobb salad, which arrived deconstructed on a tray, with the vegetables in the center, and cold ham and chicken in the corners. The green salad was lightly dressed with goat's milk green goddess dressing and was light flavorful. However, the chicken was flavorless and the ham was salty and gray, though the chicken improved when it was mixed in with the greens.

The gold-star entrée for this meal was the clams and shrimp with sausage, served in a heaping bowl anchored by a flavorful tarra-gon cream sauce that was meant for sopping (we could have used twice as many of the surfboard-shaped croutons that came with the dish).

We finally found our stride with dessert, choosing pastry chef Caroline Ramirez's Texas sheet cake and the Hildee bars. The former isn't really a Texas sheet cake apart from the flavor; traditional Texas sheet cake is a thin, single layer with a crackly, pecan-studded icing. This was a two-layer cake filled with chocolate mousse and topped with smoked pecans. It was quite yummy, but it walked so that the Hildee bars could run. These leveled-up millionaire bars are the stars of the show, without question. The shortbread base layer is crunchy and augmented with chunks of chocolate, then

topped with caramel and salted chocolate. We left nary a crumb; they alone were worth the drive from Austin, and if the folks at Hildee's are smart, they will make these available for retail sales and shipping.

The missteps at Hildee's weren't limited to the unevenness of the food, either; there were notable bumps in the service, too. The servers themselves were fine – friendly, efficient, and professional. They gamely answered questions and steered us to the most popular dishes on the menu as well as calling out their favorite items. The hosts, on the other hand, seemed confused and disconnected from the rest of the operation. On both visits, we sat for several minutes before our waitstaff greeted us; this suggests a lack of communication between the host stand and floor staff. Support staff, bless them, were trying their best, but lacked attention to detail, from trying to deliver us someone else's burgers (the tater tots smelled amazing) to sloshing a good portion of my cocktail onto the table and making no effort to clean it up. (I ended up using my dinner napkin, then having to request a clean one.)

Hildee's is a great concept with a lot of potential, and if I lived in Wimberley, I would probably frequent there for brunch, cocktails,

and desserts. But in many ways, dining at Hildee's in its current stage is sort of like driving out to Wimberley during a time of expansion: You think you're in an idyllic countryside, driving rough, curvy roads and feeling a little isolated. Then you turn the corner and there's an Amazon fulfillment center and a \$45 million electronics manufacturing facility, with more under construction. Meanwhile, staff in T-shirts and khaki shorts serve midpriced Southern food and craft cocktails inside a simulacrum of a barn. Change is inevitable, and that process creates tension; we just have to give it time. ■



Moms!
We've got your back-to-school needs right here:

the Eldorado kids' meal!

HECHO EN TEJAS

Eldorado

CAFE

Tue-Sat: 9a-10p

Breakfast: Tue-Fri 9-11a | Sat 9a-1p

Lunch/Dinner 11am-close

EldoradoCafeATX.com | 3300 W. ANDERSON LN • AUSTIN, TX

Central Market
H · E · B

LIVE MUSIC CALENDAR

WESTGATE 4477 S. LAMAR

FRI. AUGUST 26, 6:30-9

WOMEN OF WESTERN SWING | Western Swing

SAT. AUGUST 27, 6:30-9

CIENFUEGOS | Latin/Salsa

SUN. AUGUST 28, 12 - 2:30

BEAUTIFUL PHNIX TRIO | Soul/R&B

N. LAMAR 4001 N. LAMAR

FRI. AUGUST 26, 5:30-8 PM

MIKE KELLER

| Blues

SAT. AUGUST 27, 5:30-8 PM

NAJO

| Big Band

CENTRALMARKET.COM

Food News Buffet

Here's some of what's happening in Austin's culinary scene, as wrangled from numerous PR releases, words on the digital street, and even the occasional (verified) IRL eavesdroppings.

Always a lot of good eating in the capital city, ain't it so? **Black Food Week** – which goes for an entire *month*, pretty much – has already started, showcasing **more than 70 Black-owned restaurants and bars** all over the north, south, east, and west of this mighty metrop. And the annual **Austin Restaurant Weeks** are about to begin. See our event listings on this page for more.

We've gabbed at you previously about all the fermented goodness along Dripping Springs' Fitzhugh Road – **Jester King!** **Treaty Oak!** **Nine Banded Whiskey!** **Frankly Organic Vodka!** and so on – but right now we're telling you about **Beerburg** (13476 Fitzhugh), because *that badass brewpub is now open seven days a week*. Not “for the first time since the pandemic,” but for the first time *ever* – and they're kicking off the expanded schedule with specials at their on-site restaurant, **Taqueria la Violeta**. And, especially because their upcoming releases include **pecan and mesquite bean brown ale**, **sumac gose**, and a **barrel-aged Oktoberfest**, we reckon any crafty beer lover's gonna add the place to their must-visit list. beerburgbrewing.com

So the **ACC Highland area** is getting a **Paris Baguette** outpost – at 110 Jacob Fontaine – opening on August 26. Now, Paris Baguette, they're a national chain that's “on a mission to reestablish the neighborhood bakery café

as the heart of the community,” and this new location has 2,059 square feet with seating for up to 40 guests. Reckon most folks have *already* established the neighborhood's homegrown **Bennu Coffee** or **Kick Butt Coffee** as the heart of *their* community ... but of course, those places aren't also *bakeries*, and, hey – the more, the merrier, right? Welcome to Austin, y'all, and let's get a taste of those fine croissants. parisbaguette.com

Along those lines, we're totally spoiled ice-creamwise in this town, what with **Amy's** and **Lick** and **Gati** churning out their **sweet, cold miracles of confection**. And there are **Cold Stone Creamery** stores hither and yon – and, yes, **Jeni's** has been in Austin for a while, too. But now Denver's acclaimed **High Point Creamery** and **Eiskaffee** brands are ... well, they're not moving to town, precisely, but they've **debuted their goods at Central Market**, bringing the likes of **Basil With Blackberry Swirl** and **Cornbread With Strawberry Jam** and **Honey & Bergamot Orange** to the frozen dairy section of both locations. centralmarket.com

It's **National Dog Day** on August 26, as our editor-in-chief is pleased to remind everyone, and so we'll note how **Blue Lacy**, that dining spot inside the **Origin Hotel** at 1825 McBee in Mueller? **Blue Lacy** not only includes a **patio that's dog-friendly** and bedecked with a **canine-celebrating mural** by the brilliant **Heidi Pitre**, but the eatery boasts a dedicated **Dog Menu** every day – featuring unseasoned chicken or beef over rice; beef-flavored, nonalcoholic **Bowser Beer**; and doggie ice cream with four different dog-approved flavors. Mmmmm, as an English bulldog

might say, that's not 'arf bad. bluelacyaustin.com
WUXTRY! Heads-up, oenophiles: Tickets are on sale for **Texas Hill Country Wineries' Texas Wine Month Passport** deal, which runs **throughout October** at **more than 45 wineries** out there in the beautiful landscapes where the urban sprawl isn't. Get yourself a wine passport (\$85, single; \$120, couples) and you can taste at up to four wineries per day over the course of the month – and you'll get exclusive discounts on bottle purchases, too. texaswinetrail.com

Now eat as well as you can, tip like it's going out of style, and don't forget your umbrella. ■



Worth barking about: There's a special menu for dogs at the Origin Hotel's pet-friendly Blue Lacy diner

COURTESY OF ANGELA HINSON

BLACK FOOD WEEK Austin Justice Coalition presents the sixth annual **Black Food Week** – a celebration of **culture, heritage, and history (and of course the tastiest noms)**, featuring **more than 70 restaurants and bars**. And, luckily for us all, this week is actually a *month* long. “It's a sumptuous chance to cruise through the city for your breakfast, lunch, or dinner needs – from the food in Pflugerville to deep cuts in the West and newer spots in the East – and try the deliciousness the diaspora has to offer through your palate.” *Through Sept. 18. Various locations.* austinjustice.org.

SWIFT'S ATTIC: 10-YEAR ANNIVERSARY DINNER

Since opening in 2012, this popular joint's been serving up a diverse, mouthwatering mess of nonpareil deliciousness. Now help them celebrate the big one-oh at a party that's replete with **free Swifty throwback bites and appetizers** (alongside a cash bar and special guest appearances), with proceeds from the evening going to the community-forward programs of **Good Work Austin**. *Wed., Aug. 31, 7-10pm. Swift's Attic, 315 Congress, 512/482-8842. \$20.* swiftsattic.com.

AUSTIN RESTAURANT WEEKS

Excellent food, mad bargains, and community enrichment are all on the menu – *everybody's* menu – during this annual 10-day, flavor-forward fundraising event, a dining odyssey that features **specialty priced lunches, dinners, and cocktails** at restaurants throughout Austin. **Vixen's Wedding!** **Uncle Nicky's! Epicerie! Intero! Banger's! Thai Fresh! Oseyo! Aba! Show Me Pizza!** OMG, the list goes on. And, yes, part of the price of each meal goes directly to the **Central Texas Food Bank**. *Sept. 1-11. All over town.* austinrestaurantweeks.org.

SUPPORT FREE PRESS

Please consider supporting *The Austin Chronicle*. For just a few bucks, you can help us keep delivering the news.

AUSTINCHRONICLE.COM / SUPPORT

THE AUSTIN
CHRONICLE

Enjoy samples from...

ATX HOT SAUCE • AUNT MAY'S •
AUSTIN CHILI CRISP •
BLACKLICK SPICE COMPANY •
BOERNE BRAND • TEXAS STYLE
HOT SAUCE • BURN CITY
SAUCES • CASTAWAY
SAUCE COMPANY •
FANTASTIC FUEGO •
HILL COUNTRY
HOT PEPPERS •
MIKEY V'S FOODS •
MY BROTHER'S
SALSA / TEXAS
TEXAS SALSA •
OLD BONES
CHILLI CO. •
PEPPER LOVE
SAUCE • SALSA
MAYA • SALSERO
HOT SAUCE CO. •
SAVIR FOODS •
SWAMP DRAGON •
TEARDROP
PEPPER COMPANY •
WICKED PROVISIONS •
YELLOWBIRD FOODS

And take your
favorite sauces home!



Live music from...

LUNA
LUNA

TC
SUPERSTAR

MAMA
DUKE

KINDKEITH

McPULLISH
DJ'ING BETWEEN SETS

NO DOGS OR COOLERS

Buy your tickets now!

\$10 EACH / \$15 AT THE DOOR
(\$5 OF EACH TICKET IS DONATED TO THE CENTRAL TEXAS FOOD BANK)

PRESENTED BY CAPITAL METRO

SUNDAY, SEPT. 11, 3-9PM
THE FAR OUT LOUNGE & STAGE

BENEFITING CENTRAL TEXAS FOOD BANK



FOR TICKETS + DETAILS, SEE: [AUSTINCHRONICLE.COM/HOTSAUCE](https://austinchronicle.com/hotsauce) IT'LL BE OUT OF THIS WORLD

Music

KAZI, “The Voice of Austin,” Perseveres for 40 Years

Austin’s first-ever community-run station debuts new general manager and KUTX collab

Marion Nickerson wasn’t around for the founding of **KAZI 88.7FM**, but he got there as soon as he could. Just days after the station began transmitting on August 29, 1982, a 24-year-old Nickerson, freshly relocated from his hometown of Amarillo, began volunteering at the new frequency launched to serve Austin’s African American community. After a full career in community media, including years in television at **Austin Community Access Center**, the veteran now returns for a second stint as general manager of KAZI.

“I started sweeping the floors and dusting off the equipment,” says Nickerson. “I feel so blessed that I got here on the ground floor, because of the opportunities that opened up. I’ve retired from everything else I’ve done, and I’m still at KAZI. I’m still having fun.”

He stepped into the role this month, just in time to celebrate KAZI’s 40th anniversary. Before the debut of other local noncommercial outlets like **KOOP** and **KVRX**, **KAZI** established the volunteer-run, listener-supported format as Austin’s oldest community station. With a schedule heavy in hip-hop, R&B, gospel, and talk shows – alongside specialty blues, jazz, neo-soul, reggae, and oldies on Saturdays – KAZI maintains four decades as “The Voice of Austin.” (Search programs by genre at kazifm.org/shows.)

While meeting at their longtime Northeast Austin headquarters earlier this month, morning program *The Funk Train* played in the background, prerecorded, as Nickerson noted host **Tra-C** was out shopping for school supplies with her grandchildren.

“It’s community-based and socially conscious,” adds Nickerson. “It’s always experimental in noncommercial radio, because we’ve got to pay bills, but we don’t have to worry about changing our [programming] because of ratings. We’ve had several R&B-formatted stations come to Austin [over the years], and because they couldn’t make money, they changed.

“We’re still the same, because people are still listening to us.”

This Monday, August 29, KAZI will kick off an on-air anniversary campaign – organized by **Pepper Thomas** of

The Hot Pepper Show – working in memories and fundraising for the future. Nickerson hopes for visits from a few station alumni, which include media figures like **KXAN’s Quita Culpepper**, **KUTX’s Jay Trachtenberg**, and **KOOP founder Jim Ellinger**, as well as notable DJs like **Casanova**, **2DQ**, and the late **Southpaw**. Nickerson remembers **MC Overlord** as a reliable KAZI volunteer before his music took off.

The celebratory week also includes **Summer Jam**, Saturday, Aug. 27, 6:30pm, on the **Long Center Terrace** – which marks a new partnership between co-presenting stations KUTX and KAZI. **Confucius Jones**, half of hosting KUTX show *The Breaks*, approached KAZI’s **Keyheira Keys** about collaborating on the lineup of Austin hip-hop and R&B artists **Geto Gala**, **Anastasia Hera & the Heroes**, **Moody Bank\$**, and **Tribe Mafia**. Keys, a creative consultant of **Northern-Southern Gallery** and **Six Square**, hosts Monday show *Keys to the Street* and volunteers behind the scenes.

“The biggest needs are resources, funding, and volunteers with different skill sets,” says Keys. “The legacy, and the changes that KAZI has been able to withstand, is something to be celebrated, especially in a city with a diminishing Black population. Surviving as a small, independent radio station that was essentially upheaved in the pandemic – it just shows the determination of the people behind it.”

Keys brought notable weeknight evening host **DJ Hella Yella** to the station, joining a number of programming changes made during the yearlong tenure of previous general manager **James Q. Davis** and program director **Abdi “AJ” Jones**. Davis became GM last June following **Steve Savage**, who held the role since 1996. Bringing experience from **iHeartMedia**, Davis managed to



KAZI’s new (and returning) general manager Marlon Nickerson, who DJs Saturday mornings from 6 to 9am

JOHN ANDERSON

combat drops in listenership and fundraising faced during the pandemic.

Still, shake-ups on the schedule proved controversial with some listeners, particularly the addition of the nationally syndicated **Rickey Smiley Morning Show** on weekdays. This summer, the KAZI Board voted out Davis, installing Nickerson as his replacement starting August 1. Board Secretary **Beverly Shaw** told the *Chronicle* via email: “The Board of Directors felt this change was in the best interest of the station.”

Nickerson says Davis introduced a “more hyped format with more danceable, mostly fast music,” providing the example that “during the day, our DJs won’t play **Gregory Porter** or **Cassandra Wilson**, because that’s a little too slow for them.” The 2021 changes led some hosts to retire. With veteran host **J Hunt** as the new program director, Nickerson plans to maintain the existing shows while bringing the next generation into available time slots.

“We’re not going to make immediate changes,” says Nickerson. “We’re reevaluating, because some of the DJs may leave or may not. We’ve been trying to get them to stay, telling them, ‘Hey look, this is working.’ [Davis] came in and added a stricter structure, which was good, because a lot of the on-air people had become lackadaisical. He came with a corporate mindset, but everybody here was so chill and so relaxed. It was a shock to their system.

“Our only real adjustment will be giving the DJs more freedom to adjust the format as they see fit, because some of them want to play a more medium tone. Hearing fast music all the time is like going to a club, eventually you’ve got to go outside and rest. In your car, that’s just an injection for road rage on I-35.”

The station plans to launch podcasts and YouTube content in September, and seeks volunteers for these formats. Nickerson jokes about plans to drink **Olde English 800 40**

ounces with the other volunteers still on air after 40 years: **Da Genie**, **James Grey**, and gospel host **Min. Rozann Nichols**. They join other legacy DJs like **Dinky D**, **Gregg**, and **007** in mostly weekend slots.

“What makes KAZI unique is we still have live DJs,” says Nickerson. “Usually on weekends, the seasoned hobbyists come up with their turntables and do their mixes. They set their coffins up, and they go for it. The more time and freedom they have to create, the better product we get.”

KEEPING UP WITH TEXAS SLOWCORE

Fans of **Teethe** entered another dimension this week when the little-known Dallas slow-core act received a shout-out from **Kendall Jenner**. In an interview with *Rolling Stone*, the *Kardashians* star said: “I just discovered a band called Teethe and they have a song called ‘Tag’ that’s really beautiful. I love **Julia Jacklin** and **Billie [Eilish]** of course.” How Jenner discovered a murmur under-100K-plays track by an unsigned Texas act remains unknown, though the model previously spurred suspicions over the concept of culturally savvy **celebrity book stylists**.

Currently on tour opening for **Charlie Martin** of **Hovvdy**, Teethe is comprised of **Truman “Boone” Patrello**, **Graham Robinson**, **Madeline Dowd**, and locally based **Jordan Garrett**. Toting Southern-swept single “Lucky,” Teethe returns Sept. 30 for an already sold-out gig with **Momma** at Mohawk. The members also recently played **Hotel Vegas** as the excellent Dowd-fronted project **Crisman**, signed to **Topshelf Records**. Related, Martin recently announced a sans-Teethe Mohawk performance, Sept. 22, on his first-ever solo tour of 2021 record *Imaginary People* (which features an album cover by Dowd, who makes cool art at madelinecrisman.com).

EASTSIDE KINGS FESTIVAL

HISTORIC EAST AUSTIN, TEXAS

***** 12TH & CHICON ST *****

SEPT. 9TH & 10TH ANTONE'S NIGHT CLUB

SEPT. 10TH WORKSHOPS AT AUSTIN VINTAGE GUITAR SHOP

SEPT. 10TH & 11TH FESTIVAL - CORNER OF 12TH & CHICON

SEPT. 13TH AFTER PARTY AT JUSTINES BRASSERIE

WRISTBANDS
\$25 EACH DAY

AVAILABLE AT *****
ANTONE'S RECORD SHOP
OPENING AND AFTER PARTIES: PAY AT THE DOOR

**SEPT
10TH
AND
11TH
2022**

**2 DAYS
40 BANDS**

WORLD CLASS ARTISTS

**GUITAR SLIM JUNIOR
STAN MOSLEY
BOBBIE "MERCY" OLIVER
TAIL DRAGGER
RISING STAR FIFE & DRUM
GOSPEL STARZ
EUGENE "HIDEAWAY" BRIDGES
20 BANDS EACH DAY**

INFO: [DIAL@DIALTONERECORDS.COM](mailto:dial@dialtonerecords.com)

INSTAGRAM: [EASTSIDEKINGSFEST](https://www.instagram.com/eastsidekingsfest)

EASTSIDEKINGSFEST.COM

EASTSIDE
KINGS
FOUNDATION
AUSTIN TEXAS

DR. JAMES POLK



VINYL/CD/DVD
BUY AND TRADE
NEW AND USED

4304 CLAWSON RD.
512-462-6008 • endofanear.com

THE AUSTIN
CHRONICLE

Your free,
independent news
source since 1981

The Boat
Crawfish
& Seafood



22 TVs FOR BIG 10, ACC,
SEC COLLEGE FOOTBALL
& NFL GAMES

- Official Austin FC Pub Club Member
- Two Full Bars
- NEW! 30 Craft Beers on Tap!
- Fun Kids Playscape - Ahoy Little Pirates!

THURSDAY, 8/25
Cold War Camero 6PM

FRIDAY, 8/26
Copa Kings 8PM

SATURDAY, 8/27
Blazin' Kane 8PM

SUNDAY, 8/28
AngeK Band 6:30PM



The Boat Crawfish & Seafood
10931 Stonelake Blvd 78759
(512) 956-0040
www.theboatatx.com



JOHN ANDERSON

BEHIND THE WHEEL WITH DEEZIE BROWN

After five years of fine-tuning, the perfectionist producer and rapper rolls out *5th Wheel Fairytale* **BY JULIAN TOWERS**

Beyoncé couldn't quite manage it, but Deezie Brown has inspired me to quit my job.

Obviously, the job I refer to is not *this* job (Hi there, *Austin Chronicle* payroll department!), but a more soul-numbing occupation that I realized, after absorbing the Bastrop artist's total commitment to his own humongous dreams, had to be ditched for the pursuit of art and the quest for truth – even at the risk of poverty-death. How's it going so far? My refrigerator malfunctioned yesterday, liquidating \$15 of dairy items, and I collapsed in a puddle of tears. But this article isn't about me.

It's the beginning of August and Deezie Brown's music does not immediately render me in awe. This is a problem for Julian Towers, certainly, who has signed up to spin thousands of words out of the rapper/producer's latest and apparently greatest album. It's potentially an even bigger problem for rapper/producer/soon-to-be-innocent-victim-of-thousands-of-dumb-shit-words Deezie Brown. I suppose I got cocky. Fluke alt-weekly success convinced me it's possible to write passionately about local music even when you're not actually a local

or passionate. Humble is the journalist who can quench personal skepticism in order to better channel a city's hopes and dreams. Me? Humble? I guess if y'all insist.

But today the topic turns to hip-hop, a genre in perpetual forward motion where the real world come-up narratives of its superstars has never been an extra-musical concern. And look, I'm sorry, we're retrieving the diamond-encrusted cowboy hat from the center of the ring. It doesn't matter that rap regionalism died 11 years ago the moment A\$AP Rocky copped a

Houston flow on "Peso." No amount of journalistic projection is gonna will Austin frickin' Texas into a national MC export.

Listening to our ostensible grandest hope spit throwback references to Nas and Tupac over a *Muppet Babies* version of the "Black Skinhead" drum pattern, the only thing I could hear was an old-head identity crisis. Sure, the three dudes from Griselda were able to shift the culture back toward snarling, street-corner boom-bap at a combined age of 120, but their brand of street realness isn't a currency Deezie's bargaining with. Instead, he boasts about the excitement of oncoming nuptials, his hopes to rekindle communications with his brother, and the way in which his swag on the AstroTurf occasionally makes him feel like "Denis Rodman in cleats."

"It's grown folk music for normal people," KUTX DJ Confucius Jones tells me of Deezie's deeply domestic subject matter. "He's basically someone I could have been friends with in high school, reflecting on everyday Black struggle and reminiscing on music and sports that we enjoyed growing up."

Completely missing the point, I wondered: If Deezie wasn't gonna play Rap God pretend, how could I?



Deezie Brown is sitting in his home studio wearing a baseball cap emblazoned with the title of the album he released the day before, *5th Wheel Fairytale*.

"I'm joyful, but I'm also anxious," he tells me. "I don't get my album to myself anymore. There were days where I would just listen to it, knowing I was the only one who had it."

Deezie's rattlesnake drawl is the rare sort that slithers across words with purpose, each sentence lovingly considered. The comment he makes is one that will reverberate with me later when other interview subjects tell me about his extreme, near pathological perfectionism. For now, stupid, I just nod.

Throughout the first 20 minutes, our conversation dances around the fact of his music, though I don't realize this in the moment. Delving into his rural Bastrop upbringing, passion for hip-hop past and present, and his hopes for the future, Deezie repeatedly uses the phrase "my art." I, of course, take this to mean rap records, but then Deezie starts squeezing "my art" into the same sentences as "my music."

First my brow furrows. Then, my jaw drops. "Ultimately, I'm talking traveling gallery shows, being the face to movie soundtracks, scores to fashion shows, my own clothing line." As Deezie starts to list his "arts," that little rattlesnake image I have for him in my head speeds up to road-runner velocity.

I'm in awe, but also starting to panic. If nobody interrupts this dude, "rapper/producer" isn't going to merit mention for half an hour. But when I attempt to get all Moses and redirect the conversational waters toward the words on his hat, Deezie floods the whole studio. Oh no, he clarifies, *5th Wheel Fairytale* isn't a stand-alone album. It's chapter one (of five) in the soundtrack to a book (which Deezie plans to simultaneously adapt into a CGI animated movie once he figures out the technology). That little helmet-headed kid you see surrounded by Rolls-Royces on the cover is the main character.

"It's the story of this young, talented [Formula One] driver. He doesn't have a childhood because he's pushed to go to racing practice and generally do the sorts of things precluding him from actually being a child," Deezie summarizes. "It's not directly about my experience like the albums sometimes are, but y'know, I'm translating."

The most staggering revelation is still to come. I learn that in August 2019, two years into the half-decade gestation that produced chapter one, Deezie quit his job at the post office to devote his energies to art full time, thereby supporting his long-term partner and their daughter (now 6) entirely through creativity. Just a few days earlier, the deeply dejected singer of an indie band with 650,000 monthly Spotify listens told me he barely scrapes by painting houses. Deezie Brown has, at this moment, 1,854, and he emerged from a pandemic that his manager told me "decimated his revenue" more devoted to art than ever. By the time we say goodbye, I'm holding back tears, and my refrigerator is working fine.

Ironically, it takes Deezie building a galaxy outside his rap music for me to feel at home within it. Returning that evening to the all-enveloping planet that is *5th Wheel Fairytale*, I'm completely overwhelmed, totally gobsmacked, and no longer feel any desire to hop a spaceship to its occasional off-world reference points. If, like me, you approach Deezie's music fixating on the mundane, everyday familiarity of his subject matter, it can be easy to miss how much sweat and glory he expends making those subjects fucking matter. There isn't a regional rapper alive aiming this high.

The first word for *5th Wheel's* production is "opulent." The album is a lush sonic temple – each soaking-wet organ blast and high-wire guitar solo tilts in absolute devotion to the elements of Black American experience Deezie has gathered within. At a moment in post-internet hip-hop production where rappers have never sounded more isolated, more digitally delocated, Deezie is interweaving rich samples and full bands to build his tracks into communal outpourings of pure gravitas. Nearly

every song is undergirded by a cacophony of human voices, be it a cooing choir or a devastating neo-soul(o), playing off the universality of Deezie's themes.

Word No. 2 – and I do think we can agree this name long ago transcended proper noun status – is "Kanye." The progressive grandiosity West pioneered is an audible influence on *5th Wheel's* song-altering beat switches, and Deezie won't dispute it. He'll tell you he spent years studying (Deezie uses that word a lot, "studying") Ye's post-production mastery, not simply for empty-headed mimicry, but to apply the same breadth of vision to his Southern backyard. The difference is Deezie doesn't have to blow reality up to epic proportions to make us hear the grand, cosmic beauty in those surroundings. He feels no need to spit anything but humble truth to animate his braggadocious, steamroller flow. He's wearing the helmet, sure, but we're all packed into this race car together. Godspeed.

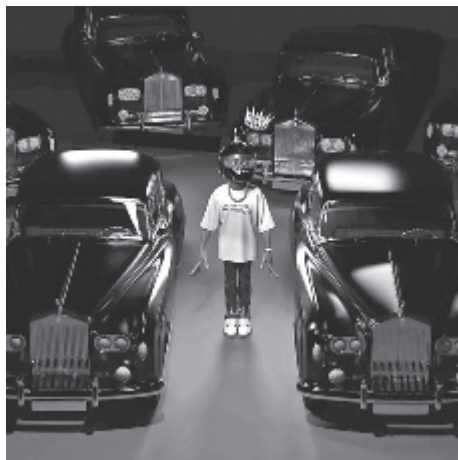

It's a foundation. You're not supposed to fuck around with it. The year is 2002 and the Neptunes have just unleashed Clipse's "Grindin'." Chad Hugo and Pharrell Williams stumbled into a percussive loop so primeval, so raw – it could basically be the first beat ever programmed – they barely bothered to build the thing into an instrumental (not that the Neptunes were ever much for embellishment). This proves to be of great convenience when the track, already indistinguishable from the sound naturally produced by banging on a cafeteria table, becomes the default rhythm for lunchtime freestyle competitions.

So, yeah, you gotta be a real cocky son of a bitch to fuck around with the "Grindin'" beat, but that's just D (short for Devin) Brown. When it's his turn to pound out those iconic drums, he also adds perfectly placed little fills by tapping a pencil on his lunch tray. Reactions are ... mixed.

"We're looking at this guy like, 'OK, calm down, stick to the beat,'" recalls Deezie's cousin Doug Peterson. "You don't have to show out like that!" But D can't help it. He's inherited a head full of sound.

"It all came from my father, you know he was in high school in the late Eighties, and he had a huge collection of hip-hop records that passed to me," Deezie recalls. "I started studying the back of CD covers before I could read."

Deezie developed a hip-hop knowledge base almost by happenstance. Spending his days riding through small-town Bastrop in the back of his father's green C10 Chevrolet pickup – the 12-inch subwoofers blasting everything from rough-hewn Mobb music to polished Bad Boy pop rap – Deezie's upbringing allowed him no vantage on distinctions between East, West, and South. Instead, the most significant context that imprinted itself on hip-hop was the pickup itself, and the other go-karts, dirt bikes, and assorted vehicles that came along with the Peterson family car club: the Blue Flame Cruisers.

So, like many a Southern rapper before him, pimped-out rides were what D rapped about. The young man was all of 15 when he hit the streets (and, y'know, Myspace) to peddle his first mixtape of woozy Houston-style slab rap. Though his C10 studies initially manifested in the makeshift loops he and Doug recorded off one another's boomboxes, thanks to his friend and rap partner EC Mayne, he soon found himself recording in real studios with associates of EC's late cousin DJ Screw.

Yet even as he collected the pieces, D Brown wasn't building toward a hip-hop future. His adolescent dream was to shepherd his barber father's unrealized aspirations in professional sports. But when Devin ended up at Houston's Texas Southern University he wasn't on the gridiron. He was pursuing a criminal justice degree that left him drained and apathetic. When Deezie credits a Kanye record with inspiring him to abandon his freshman year for a life of artistry, you wouldn't be blamed for assuming he's talking about, y'know, *The College Dropout*.

You'd be wrong.

"Graduation made me drop out. I know, I know," Deezie laughs. "But I felt he was speaking to me. I knew I was ready to put my marbles into making music and into being an artist."

Brown returned home, built an in-house studio, and started churning out material as Deezie Fresh. It turned out to be a leap of faith right into a raging inferno. His in-house recording studio was completely wiped out when the 2011 Bastrop County Complex fire rampaged through his neighborhood. Though his jam-packed hard

CONTINUED ON P.52

LIQUIDATING!

LOST OUR LEASE!

Over 40 years of
Chronicle back issues

are being consolidated as we have
to move out of the warehouse
where they're stored.

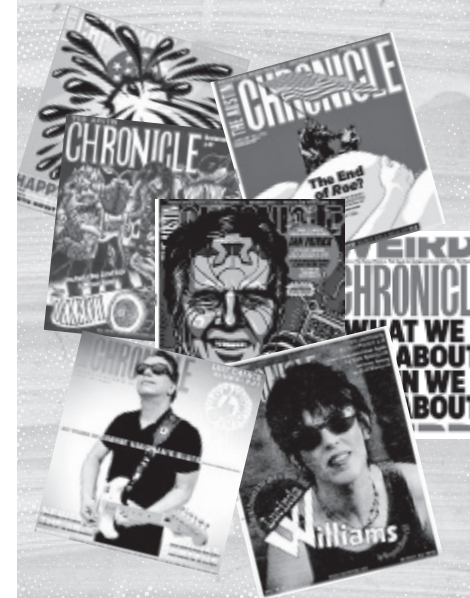

EVERYTHING MUST GO!

1 COPY FOR \$5, 10 COPIES FOR \$10,
AND UP TO 50 COPIES FOR \$20.

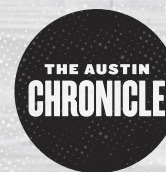

Call 512-454-5766 for more info
austinchronicle.com/subscriptions

DEEZIE BROWN CONTINUED FROM P.51

drives were lost forever, Deezie's human drive was only burnished. You can call it his RZA flood moment.

"If anything, the fire gave him *fire*," recalls Peterson. "He had to go harder than ever cause he learned it can all go up in an instant."

Moving 30 miles west into Texas' capital city just to figure out what was next, Deezie connected with his cousin Kydd Jones, a well-established rapper of Austin's LNS Crew. "Just let me rap with you, I'm not looking for no spotlight," Deezie recalls asking. "Just a place to ride with some cats and build a community."

He got a spotlight anyway. Local luminaries recall Deezie immediately standing out, rocking vintage gear that coalesced with a throwback sound quite unlike the nascent trap mined by his generational peers. The hype for his debut mixtape *Hoop Dreams* even scored him a headliner release show at Mohawk.

"You had some people who were wearing throwback jerseys, sure," recalls KUTX DJ Aaron "Fresh" Knight, "but nobody else creating an aesthetic around it and catering the music to fit the look."

Fresh built a wave of crucial hype for the rapper by naming him to his mock XXL freshman list in 2012. When the amp blew at the corresponding cipher performance, Deezie got yet another chance to fortify his brewing legend. Rather than wait for a replacement, he spat his whole freestyle a cappella. "Everybody was just enamored," recalls Fresh, still dazed with awe.

Well, almost everybody.

"Sure, the talent was there, but he didn't have his voice yet," Confucius remembers. "He needed to go away to find himself."

Yet the material Deezie did reemerge with – following five years spent reevaluating his artistic priorities, scribbling lyrics, and tapping out beats in the burning belly of his mail truck – he now considers something of a false start. Though much beloved by hardcore fans, 2018's *Judith* gets little love from Deezie today. Catch him on a bad day and he'll call it a straight *80s & Heartbreak* rip. Indeed, Kanye's 2008 Auto-Tune temper tantrum is a clear precedent for the album's chilly sonics and uncharacteristically bitter raps. Though Deezie has scrubbed the record from most streaming services, claiming its incongruence with his current material, one crucial piece of *5th Wheel* imagery does remain from the *Judith* era: the helmet on the album cover – a nod to Deezie's Bastrop childhood behind the wheel.

That cover proved decisive in more ways than one. When a young Austin-to-L.A. producer encountered the art through a chance Twitter scroll, he started listening to the album while driving downtown and immediately pulled over to shoot Deezie a DM.



Deezie deconstructed: Brown, pictured at a Bastrop-area salvage yard, has been turning wrenches on 5th Wheel Fairytale for half a decade

JOHN ANDERSON

"If you give him time, he will never stop working till you pry it out of his hands, and that's great but also problematic. People are constantly moving onto the next thing, so artists break big today through constant content, but Deezie's not cheap like that."

MALIK

"The Kanye influence was too on the nose, but the guy was so obviously next-level talented," recalls Malik, who later earned a Grammy Certificate for crafting the beat to Ariana Grande's "Better Off." "I messaged him like, 'This is great, but I need to hear where you're from and what you're about.'"

As a matter of fact, Deezie was at that moment in the earliest stages of conceptualizing a project that would finally speak from his soul. Merging a newfound interest in character-based storytelling with foundational Southern melodies in UGK and Outkast, these latest songs reached back while imagining forward – "dances of reality with fantasy," he calls them. When Malik started sending Deezie lush, future-forward beats to mess around with, the producer was shocked by the deluge he received in turn.

"The guy was ready," Malik says. "He had verses for days, months, years."

Literally. Though Brown found time to lend his production and emcee skills to

full-length collaborations with EC Mayne and Jake Lloyd, the gap between Deezie's first and second album was almost as long as his initial exodus from the Austin scene. Yet according to Malik, *5th Wheel* was actually "finished" as many as six times. Each time the record was mastered, Deezie would come back two weeks later with "a completely new tracklist and five more songs."

"Everything that he does, from playing video games, to sports, to fashion, to recording, to songwriting," agrees Peterson. "He is just too much the perfectionist."

"If you give him time, he will never stop working till you pry it out of his hands, and that's great, but also problematic," Malik says. "People are constantly moving on to the next thing, so artists break big today through constant content, but Deezie's not cheap like that."

This is a concern I share as well, but that's tomorrow. Today, the fruits of Deezie's long-term labor remain freshly self-evident.

"It's a masterpiece," Fresh tells me. "If people say it's not the best Austin album of 2022 then I honestly don't know what they're listening to." I'm inclined to agree, though Confucius is characteristically more reserved in his response.

"Fresh is quicker to the trigger than me," he cautions before hastily conceding. "It's definitely top five."

Weightier than the approval of any media figures, though, is Deezie's reception in Bastrop. According to Peterson, the locals have in the past had a "hard time tapping into" Deezie's grand vision, tending to skew traditional H-Town in their hip-hop appreciation. All the more significant that on August 6, Deezie was granted the honor of becoming only the second Black performer (following his cousins, the talented funk/soul/blues jammers the Peterson Brothers) to headline the town's homecoming rodeo. I have no trouble believing that his 90-minute set lit the fucking field on fire.

"This is your Bun B at the Houston All-Stars moment," Peterson says he told Deezie. "When I think about your journey from a little single wide trailer house to playing these stages, man, I get tears in my eyes."



The star power is there. What's it gonna take to blow this dude up? That's the impasse I reach in all my conversations about Deezie for this article. The consensus seems to be "some kind of internet miracle."

"I just think he needs the right song to go viral," says Fresh. "That one hot track that sets the web ablaze."

"He's just one spark away," agrees Malik. "He's already laid the wiring out, just put some fuel on this and boom!"

I, too, would like to believe Deezie Brown has a TikTok-friendly flute loop lingering in the chaotic detritus of his abandoned back catalog. But the part of me that is now unemployed because I was moved by this man's unwavering self-belief knows different. When that green C10 Chevrolet parks at its ultimate destination, it'll be because Deezie has turned the ignition himself.

"I'll use my skill set to get me where I want to go, but ultimately I've always wanted to be the mind behind the projects and not really the spotlight," he tells me, just before we hang up and he goes off to celebrate his birthday with his daughter. "I'll be the guy producing the soundtrack for movies, it's gonna happen. I'll choose that over being on a stage in front of 50,000 people ... though it'd be neat to do that first." ■

***5th Wheel Fairytale* is on streaming services now. Deezie Brown performs with his Jake Lloyd collaboration *Geto Gala* for Summer Jam, presented by KAZI and KUTX Saturday, Aug. 27, at the Long Center, 701 W. Riverside. Get tickets at thelongcenter.org/events/summer-jam.**

Lucktoberfest

Nov. 1 Oct. 31 Oct. 30 Oct. 29 Oct. 28

A TEXAS-SIZED KICKOFF CELEBRATION **Featuring** PAUL CAUTHEN'S BIG VELVET REVUE

OUTLAW MASQUERADE BALL **With** ORVILLE PECK, DISKO COWBOY, THE JIGGLEWATTS, JASON SCOTT

PROST, Y'ALL! "LUCK-OKTOBERFEST" **Featuring** ALEX MEIXNER AND FRIENDS, WALBURG BOYS, ALPENMUSIKANTEN, TANZENFEST, YODEL BLITZ

LUCK-O-LANTERN HALLOWEEN FAMILY NIGHT **With** A Special MATTHEW LOGAN VASQUEZ And Friends SPOOK-TACULAR, RYAN QUIET

DIA DE LOS MUERTOS EXPERIENCE **Featuring** LOS LOBOS, BIDI BIDI BANDA, AZUL BARRIENTOS, VANESSA CHERRY & MARIACHI MARTINI, CONJUNTO HERITAGE TALLER

Nov. 2 THE BLACK OPRY REVUE **With** FANTASTIC NEGrito, ADIA VICTORIA, BLACK OPRY REVUE ARTISTS-IN-THE-ROUND, JON MUG

Nov. 3 LUCK NIGHT MARKET **Featuring** SASAMI

Nov. 4 DESERT ROSES QUEER SOUTHERN GLAMOUR **Featuring** A FASHION AND VARIETY SHOW

Nov. 5 SWEETHEARTS AND A RODEO **With** TANYA TUCKER, SIERRA FERRELL, NIKKI LANE, GUTHRIE GIRLS

Nov. 6 BLOODY MARY MORNING **Featuring** BOB SCHNEIDER, SHINYRIBS, JOHN EVANS

AND MUCH, MUCH MORE

10 DAYS WILLIE NELSON'S LUCK, TX

SCAN FOR TICKETS



ON SALE NOW ON SALE NOW ON SALE NOW ON SALE NOW



THE FLAMING LIPS

OCTOBER 1, 2022 SCAN FOR TICKETS

luck, tx
1100 bee creek rd
spicewood, tx 78669



EPISTROPHY ARTS PRESENTS: ATOMIC

The Draylen Mason Studio at KMFA, Wednesday 31

Like a lot of us, improvisational music specialists Epistrophy Arts spent the pandemic hibernating. But the long-running institution – which celebrates its 25th anniversary next year – revived with three shows so far this year, the latest of which features veteran Scandinavian jazz quintet Atomic. Consisting of saxophonist Fredrik Ljungkvist, pianist Håvard Wiik, trumpeter Magnus Broo, drummer Hans Hulbækmo, and bassist/former Austin avant-jazz hub Ingebrigt Håker Flaten, the Swedish/Norwegian blend has collaborated with EA thrice before: at the Victory Grill in 2008, at Beerland in 2018 (in partnership with local experimental label Astral Spirits), and at Blackerby Recital Hall in 2019. This gig is something special, however: It's the last U.S. tour for the foreseeable future.

"They're disbanding after 20 years," explains EA majordomo P.G. Moreno over coffee at La Madeleine. "That's a little bit of a bummer, but I definitely wanted to be part of their tour." ("A joint decision due to family commitments etc. to call it off after 20 good years," confirms Håker Flaten.)

Reflecting on what led him to book Atomic that first time, Moreno elaborates, "We'd already had the Thing [the Scandinavian Action Jazz trio that also featured Håker Flaten]. Atomic was more representative of the Scandinavian jazz powerhouses, but with their own approach. Individually they were amazing instrumentalists. It was just really exciting and fresh."

The Atomic show follows innovative Colombian rock act the Meridian Brothers' successful Aug. 16 gig at Antone's, and jazz legends Andrew Cyrille and Billy Harper's spectacular May 7 show at a packed Scottish Rite Theater, which Moreno calls "probably the most successful show we ever presented." Consider it a rousing comeback after two years under the radar. "We partnered with Sonic Transmissions [Håker Flaten's music promoter/festival] to do the [livestreamed] Movement in Stasis Festival," says Moreno. "But I wasn't motivated to pursue a lot of streaming and digital projects. I missed the sense of community and space, and enjoying music in a room collectively and connecting with a band." The result of years of effort, the Cyrille/Harper show was originally on deck for April of 2020, and Moreno refused to let it go. "I'd been talking about it for four years, and it was starting to feel like people didn't really believe me. It was like I was talking about some girlfriend I have that goes to another school. So I had to make this happen."

EA's presentation of the Meridian Brothers was nourished by a built-in fan base for their unique fusion of traditional Colombian sounds



Atomic at Beerland

PHOTO BY P.G. MORENO

and experimental rock. "By some force, we have this amazing Afro-Colombian roots scene that's unique to Austin – it's not anywhere else," he says, echoing the sentiments of local Colombian spark plug Kiko Villamizar. "I'll borrow the phrase 'ancient to the future' – we've got these super heavy-duty traditional musicians, and then we've got Money Chicha and Superfónicos."

Moreno hopes to forge close ties between the improvised music scenes in Austin and Colombia – and beyond. "We're trying to connect Norwegian bands with Texas bands, with Chicago and Colombia, and create some kind of partnership," Moreno explains. "We kicked that off with Ingebrigt and I traveling to Bogotá about six years back, him playing, and meeting folks, including members of the Meridian Brothers. The venue Matik Matik, which is sort of a cultural center where many of these activities happen – they've hosted performances by Peter Brötzmann, the Thing, and various other groups. The aesthetic is there, but a lot of folks here don't understand how Epistrophy Arts is involved with this Colombian music. [Colombians] are big fans of this stuff, as we are, and we want to create this international network because there's young audiences there that are just amazing. They'll show up on a Wednesday night to hear some free jazz in Bogotá."

From spreading the word about the world's great improvisers to assisting cultural ambassadors in bringing their art to Austin, Epistrophy Arts' purpose is all in the service of the music. "It makes me happy that I'm bringing this great creativity from afar with people that are my friends and part of my global community, and I'm introducing them to my friends here," Moreno discloses. "I'm very, very fortunate. All of the trepidation and worry about the future and all that – I feel the best and most confident I've ever felt about Epistrophy Arts. I know that it's something solid. There's an instinct that I have that seems to be working. The mission is strong and clear, and I'm committed to it." – Michael Toland

HERE & THERE FESTIVAL: COURTNEY BARNETT, INDIGO DE SOUZA, ETHEL CAIN

3ten ACL Live, Thursday 1

Punctuated by staccato chord stabs, Courtney Barnett sings a nomad manifesto on "Scotty Says" off 2013's *The Double EP: A Sea of Split Peas*: "I got lost somewhere between here and there/ I'm not sure what the town was called." The song story-tells her formative years of vagabonding across the Australian desert to perform and touring across unfamiliar destinations in North America and Europe.

Eight years later those dots on a map have transformed into a rich connection of musical communities. Like a hand-picked mixtape, the Here & There Festival sports a different lineup for each city, with Austin's being Barnett, Indigo De Souza, and Ethel Cain.

On last year's *Any Shape You Take*, De Souza wrings out heartache drip by drip. Love glimmers only for a second like a "fleeting lover, grocery goer" in "Late Night Crawler," but heartbreak lasts a lifetime where remnant thoughts of an ex linger like a ghost.

Off the heels of her debut *Preacher's Daughter*, Hayden Anhedonia's alter ego Ethel Cain unspools a yarn that threads familial trauma and the stranglehold of a Southern Baptist upbringing. Recorded and produced in her bedroom, the album teases pop charm as the single "American Teenager" encapsulates the blooming guitar slabs of an epic Eighties ballad while interpolating an American fantasy of youthful ennui.

– Alejandra Ramirez

Courtney Barnett



PHOTO BY MIA MALA-MCDONALD

BUTCH HANCOCK

04 Center, Saturday 27

How rare did Butch Hancock sit-downs become during this jolly old pandemic? From now until November, Terlingua's poet laureate lists one show a month on his website: Austin, Fredericksburg, Terlingua, and Galveston. The second locale reunites his Flatlanders to head up the Back to the Basics Music Festival after the Lubbock triumvirate's five-star *Treasure of Love* yielded raconteur relief deep in the heart of COVID, summer 2021. The third destination pairs him with mystic counterpoint Jimmie Dale Gilmore, plus maybe Joe Ely's *Austin City Limits* Hall of Fame induction this October reconvenes the super trio. That leaves this South Austin one-off to fulfill fantasies of seeing Townes Van Zandt at the Cactus Cafe.

– Raoul Hernandez

THE REOPENING OF KINGDOM

Kingdom Nightclub, Saturday 27

Beloved raver institution with a second shot at life after an unceremonious, unexpected lockout in a grim 2018 fiasco, Kingdom Nightclub reopens this week with a secret DJ lineup we aren't supposed to know about (but do) and must hint on, because obviously. With former booking partners in their own club by the airport, Kingdom 2.0, now at 505 E. 7th, is icing on the comeback cake. Owner Garrett Boyd said he wants to book and nurture fresher talent. A dear Texas native son, multi-techno-aliased, spooky Midwestern twin label co-founder, shape-shifting, tie-dyeing amateur mycologist touring with an archduke opens.

– Christina Garcia

ROBERT EARL KEEN

ACL Live, Sunday 28 – Monday 29

The road may go on forever, but the party is coming to an end. Robert Earl Keen, acclaimed Texas songsmith and influential figure in Americana music, is closing the curtains on his 41-year-long touring career. He began performing in College Station in the Seventies, moved to Austin after graduation, and played iconic venues like the Cactus Cafe, Liberty Lunch, and Gruene Hall. After trying his hand in Nashville, he returned home, continuing to spread his uniquely Texas voice and style across the land. Thankfully, he's not hanging it up for good without one more party in Austin.

– Robert Penson

KID CUDI

Moody Center, Wednesday 31

Scott Mescudi's generational humming could resurrect a charred garden from the ashes. Scott Mescudi's soothing hum can launch a wretched soul into clouds of serenity. That "hmmmm" and influential 2009 debut album, *Man on the Moon: The End of Day*, bought the Cleveland rapper eternal goodwill among a passionate collective of twentysomethings who probably strolled through school hallways puffing out lyrics to "Day 'n' Nite." Though Don Toliver pulled out of Cudi's tour citing production/logistical challenges, GOOD Music signee 070 Shake will still provide support in the form of synth-heavy, croon-filled enchantment.

– Derek Udensi

MARISSA NADLER

The Ballroom, Thursday 1

Austin's most evocatively named venue is more likely to host emo nights than opulent masquerades. Even so, you could probably trick me into believing Saturday's performer has an album of haunted gothic folk titled *The Spiderhouse Ballroom* somewhere in her expansive, 20-year back catalog. As Nadler's music progresses further past its spare, acoustical roots (these days, she's collaborating with former Cocteau Twins on albums titled after clouds, which should give a sense of the sonic lushness), her live shows become increasingly valuable. A chance to hear one of indie's ghostliest artists at her most entrancingly spectral. Openers include drag star Louisiana Purchase and noise jam travelers Water Damage.

– Julian Towers

• NOVEMBER 18TH 2022 AT HAUTE SPOT •

ARCANGELS

MADAM RADAR

HAUTE SPOT

LOCAL LICKS
WI LORIS LOWE

Lightstream
PRESENTS

93.7 KLBJ

BUY TICKETS TODAY AT WWW.HAUTESPOT.LIVE

LIVE MUSIC

ALL AGES VENUE ROADSHOW RECOMMENDED

THURSDAY 8/25

The ABGB Fuzz & Friends (7:00)

ACL Live Lyle Lovett & His Large Band (8:00) **R**

Ah Sing Den Secret Garden w/ Lonnie Burnside, Brett Johnson, Brother Pate (9:00)

The Alcove Cantina Meg & the Bad Eggs (7:00)

Antone's Missio, Tempoh Slow, Wildman (9:00) **R**

Armadillo Den Tylor Brandon (7:00) **R**

Baker Street Texas Live Band Karaoke (9:00)

Beerburg Brewing The Merles (8:30)

The Boat Wampus Cat (6:00)

Broken Spoke Joshua Hedley (9:00), Tracie Lynn (6:00)

Buck's Backyard W.C. Clark (6:00)

Buddy's Place Glen Collins open mic/ jam (7:00)

Butterfly Bar Frederico7 (8:00), Everett Wren (7:00)

C-Boy's John Branch & Friends, Zapata (10:00), Mel & James [jade room] (10:00), Robert A. Kraft (6:30)

Carousel Lounge WK & Company (9:00), Beach Angel (7:00)

Celis Brewery James Hearne (6:00)

Cheatham St. Carson Jeffrey (8:00) **R**
Cherrywood Coffeehouse Ryan Morris (8:00) **A**

Chess Club Megafauna, Darwin's Finches, Bernardo Mountainair (9:00) **R**

Circuit of the Americas One Republic, Needtobreathe (7:00) **R**

Come & Take It Live Incantation, Goatwhore, Bewitcher, Whore of Bethlehem (6:00) **R**

The Concourse Project J. Worra (10:00) **R**

Continental Club Barfield the Tyrant (10:30), Casper Rawls (6:30)

Continental Club Gallery Western Union Man (10:30), Barbara Nesbitt (8:30)

Devil May Care Eli Arbor (8:00)

Donn's Depot Murphy's Inlaws (9:00)

Driskill Bar Danny Britt (8:00)

El Mercado The Drakes (7:00) **A**

The Electric Church Alive w/ Christian Bland, Ramiro Verdooren, Prieto Bosques, Lechita Kandy (9:00)

Elephant Room B-Side Quartet (9:00), Mitch Watkins Trio (6:00)

Empire Control Room Anuhlea [control room] (9:00), Boris, Nothing [garage] (9:00) **R**

The Far Out Tonstarttsbandht, Gus Baldwin & the Sketch (8:00) **R**

Feels So Good Mrs. Glass, M.J. King Snake (6:00)

Friends Paul Val (11:00), Sonny Wolf (7:30), Jac Carson (11:30am)

Geraldine's Birds, Bubbles, & Blues w/ Tye Miles & the Hard Times (9:00)

Giddy Ups Open mic w/ Dewey Lyon (7:00)

Gruene Hall Matt Kirk & the Güeyfarers (6:00) **R**

Guero's Jonas Alvarez Band (6:00)

Half Step David Tucker Band (9:30)

Haute Spot Led Zeppelin 2 (7:00) **R**

Hays City Store Chuck Shaw (7:00)

Hole in the Wall Juniper Berries, Dimitri, Jack Ferrara (9:00)

Hotel Magdalena Liquid Courage Happy Hour w/ Jane Ellen Bryant, Brody Price [valet lobby] (5:00)

Hotel San José Kathryn Legendre (5:30)

Hotel Vegas Chucky BLK (single release), RGB (album release), Madison Baker, Ukeme (9:30) **R**

Hudson's on Mercer All Star Jam w/ Natasha Hudson, Chad Hudson, Joey Resendis (8:00)

Kick Butt Coffee The Inferno Show w/ Gilded Lows (8:00) **R**

King Bee Blue Mist (8:30)

Las Palomas S7VEN (6:00) **A**

Little Longhorn Johnny McGowan's Rugged Gents (9:00), Hog Branch (6:00)

Lone Star Court Ella Reid (7:00)

Long Play Lounge East Pink Noise Tapes showcase (9:00)

The Lucky Rabbit Gus Clark (6:00) **R**

Maggie Mae's Leander Denny Herrin (7:00)

Mavericks Dance Hall Buda Giovanni & the Hired Guns, Canaan Bryce (9:00) **R**

Meridian at Zoi Market Roots & Jazz w/ Bryan Pardo & Lynn Ray (7:00)

Mohawk Youngtones, the New Essentials [inside] (9:00) **R**

Monks Jazz Club The Hubtones (7:30)

Moody Center Swedish House Mafia (8:00) **R**

Mozart's Jon Parmentier (6:00) **A**

NeWorDeli Danny Fast Fingers (7:00)

Parish Hello Seahorse!, Lolita Lynne, Tortuga Shades (8:00) **R**

Parker Jazz Club Emmaline (9:30, 7:30) **R**

Parmer Lane Tavern Angelyn (9:00)

Poodies Alan Haynes (8:00), Jimmie Dreams (6:00)

The Porch Marco Felipe Band (10:00), Lynn Crossett (8:00)

The Railhouse Jamie Krueger & Friends blues jam (7:00)

Riley's Tavern Mary-Charlotte Young (7:00) **R**

Rustic Tap Anthony Wright (8:00)

Sagebrush Wil Cope, Jenny & the Corn Ponies, Dave Insley's Careless Smokers (8:00)

Sahara Lounge Aromad, Artemis Ascending, Vibe Alive Jams, Ryan Fauber (8:00) **R**

Sam's Town Point JD3 (10:00), Ted Roddy (9:00), Western Fidelity (Sammi Smith tribute) (8:00), two-step dance lessons w/ Double or Nothing (7:00)

San Jac Saloon Will Southern Band (9:00), James Delgado (5:00)

Saxon Pub David Touchton (10:00), Patrice Pike (8:00), PAACK (6:00)

Seareinas Guerra de Bandas w/ Banda La Mas Querida contra La Banda 614 (8:00) **R**

Shore Raw Bar Honeybee Jazz Quartet (6:30)

Speakeasy Nolo (9:30)

Spokesman Acclimated Assassin, Full Phonetic (7:00)

Summit Rooftop Buschy, Ax, Aevum, Lea (10:00) **R**

Valhalla Lord Friday the 13th, Fragile Rock, the Dead Coats (10:00)

The Venue ATX Henry Fong, Arius, Blaze, Kevin Brown (8:00) **R**

Vincent's on the Lake Blazin Kane (7:00)

The White Horse Croy & the Boys, Harvest Thieves, Dallas Burrow (8:00)

FRIDAY 8/26

O4 Center Will Taylor's the Living Score w/ Strings Attached Trio ft. Christabel Lin & Tony Rogers (Beethoven tribute), spoken word w/ Meagan Weaver (8:00) **R**

The ABGB Cold Jackets, JeTexas (9:00) **R**

ACL Live Lyle Lovett & His Large Band (8:00) **R**

Anderson Mill Pub Stone Crow (9:00)

Angel's Icehouse Rochelle & the Sidewinders (8:00), Troy Stone (6:00) **R**

Antone's The Damn Torpedoes, Tumbling Dice (9:00)

Armadillo Den Jason Kane White (8:00)

Austin Eastciders Barton Springs Datura (7:00)

Baker Street Cap City Band (9:00)

Bar 620 Lonestar Souvenirs (9:00)

Beerburg Brewing Billy Blanchard (6:00)

Black Sparrow Fea, the Black Birds (8:30) **R**

The Boat The Copa Kings (8:00)

Brass Tap Round Rock The Riffs & Chips (9:00)

Brentwood Social House Michael Gailinas (9:00am)

Broken Spoke Wagoners w/ Monte Warden (9:00), Ian Stewart (6:00)

Buddy's Place Mudlark (8:00)

Bugle Boy Natalie Price & Ben Jones song swap (8:00)

Butterfly Bar C'est La Vida (9:00), Johnny Holden (7:00)

C-Boy's JeTexas, Jake Andrews (9:30), Henri Herbert (6:30)

Carousel Lounge Variety Jones (5:00), Inflatable Baptists (11:00), Monkeyshines (10:00), Amber Eye (9:00), Red River Trucking (7:00)

The Cathedral August Open House w/ Tearjerk (8:00)

Celis Brewery Garrett J. Brown (6:00)

Central Machine Works Honey Made (8:00)

Central Market North Mike Keller (5:30) **R**

Central Market South Women of Western Swing (6:30) **R**

Cheatham St. Drew Fish Band (8:00)

Cherrywood Coffeehouse Alex Mills (8:00) **A**

Chess Club JT Whitfield, Save Our Children, Mental Abortion, Necklace, Nanna, DJ I-3 Olivia (9:00)

Circuit of the Americas Suicideboys, Ski Mask the Slump God, Maxo Kream, \$not (7:30) **R**

Coliseum Calibre 50, Banda Carnaval, Cuarto de Milla (9:00) **R**

The Concourse Project No Mana, Eddie (9:00) **R**

Continental Club Soul Man Sam & the SMS Band (10:00), The Blues Specialists (6:30)

Continental Club Gallery Josh Perdue (10:30), Briscoe (8:30)

Copper Shot Distillery Dom Cours & Company (7:00)

Coupland Dancehall Cody Hibbard, Joshua Hedley (8:30) **R**

Devil May Care Skratz Bastid, Miles Medina (9:00) **R**

Donn's Depot Donn & the Station Masters (8:30)

Driskill Bar Dave Insley (8:00)

Elephant Room Fresh2Def Horns (8:00), Tomás Ramirez (6:00)

Empire Control Room Van Full of Nuns, House Parties, the Idle Kind [control room] (9:00) **R**

The Far Out David Ramirez jamboree w/ Matthew Logan Vasquez, Greyhounds, Kalu & the Electric Joint, Matthew Mayfield, Andy Davis (8:00) **R**

Farground The Castaways (6:30)

Flamingo Cantina The Shake, Nuclear Nation, Lemon Disco (9:00) **R**

Friends Bercy (noon)

Geraldine's Nik Parr & the Selfless Lovers (10:00)

Giddy Ups Bakersfield TX (8:30)

The Green Jay Cabrini Green (album release), Quiness, Personality Contest, Bohl, DJ Amanda Koontz (9:00)

Gruene Hall Max Stalling, Ethan Hanson (8:00) **R**

Guero's Jon Blondell Project (7:00)

Hanovers Mob Rules, Denim & Leather (9:00) **R**

Hill Country Galleria Havins (7:00)

Hole in the Wall Dead Billionaires, Space Tan, Campaigner (8:00) **R**

Hotel Vegas Brainstory, Indoor Creature, BluMoon (9:00) **R**

Hudson's on Mercer Bd Dueling Pianos (8:30)

Indian Roller Friday Night Get Down w/ Daetron Vargas, Czech One (9:00)

Infamous Brewing Gus & the Dirty Bones (6:00)

Kick Butt Coffee Stitched Up, Worm Suicide, Tibetan Sky Burial, Vulture Christ (9:00) **R**

Lake Austin Spa Resort Lloyd Miller (7:30)

Little Longhorn Bob Appel (9:00), the Defibrillators (6:00)

The Local Outpost Teddy Long (9:00)

Lone Star Court Michael Ingalls (8:00)

Long Play Lounge East Jess Kerber, Gianne Villaverde, Uncommon People (9:30), Rent Party (7:00)

The Lost Well War Cloud, Peth, Tempress (9:00) **R**

The Lucky Rabbit Southern Angels (9:30), Robert Mokry (6:00)

Maggie Mae's Leander Ryan DeSiato (8:00)

Mercer Dancehall The Golden Roses (8:00)

Mohawk Death Bells, Smirko, Grivo [inside] (8:00) **R**

Moody Center PBR Gambler Days w/ Kane Brown (7:45) **R**

Moontower Saloon Sonny Wolf (9:00)

Mozart's Dan Peters (6:00) **A**

Neighbor's Brian Wolff Trio (7:30)

NeWorDeli The Songbirds (7:00)

Oakwood BBQ Blues, Brews, & BBQ w/ the Larry Harris Band (7:00)

Parish The Front Festival w/ Chanté & Orya (Pushin' Pink afterparty), We Don't Ride Llamas, Lord Friday the 13th, Kiki Machine (8:00)

Parker Jazz Club Great American Songbook Selections (9:30, 7:30)

The Pershing TheBrosFresh (8:00)

Planet Rock Tina Jackson Band (8:00)

Poodies Traces Left (10:30), Glen Collins (8:00)

The Porch George Mercado Group (10:00)

The Railroad 80H Project, 3 Pc. & a Biskit (8:30)

Riley's Tavern Miss Lavelle White's L Men (8:00) **R**

Rock House Bar Tauranga (8:00)

Round Rock Tavern Semi Charmed Life (9:00)

Rustic Tap Jah & the Resophonics (6:30), Rochelle & the Sidewinders (4:30) **R**

Sagebrush Wilkinson's Quartet, the Jerrells, Gin Racers (7:00)

Sahara Lounge Mala Nota, OndaStereo, Jose Pasco, Paula Maya & the Bossa Nova Plus Project (7:30) **R**

Sam's Town Point The Last Jimenez (10:00), George Carver (8:00)

San Jac Saloon Tylor Brandon Band (10:00), Joe Vega (3:00)

Saxon Pub Ransom Brothers feat. Juliana (album release) (8:00), TG BAD (6:00)

Shooters Cedar Park Suede Austin (9:00)

Shooters North High Road (9:00)

Shore Raw Bar The Basil Trio (7:30)

Sidecar Tasting Room Joseph Jay (5:30)

Skylark Lounge Keesha Pratt (9:00), Cassandra Eiese (6:00)

Slackers Jazz Daddies (6:00)

FLAMINGO CANTINA

August Summer 2022

FRI. 8-26 THE SHAKE
+ LEMON DISCO & SPECIAL GUESTS - \$5

SAT. 8-27 AUSTIN WE LOVE REGGAE
TURBULENCE, TYDAL KAMAU, TEFLON \$30

WED. 8-31 DREADNECK WEDNESDAY
MAU MAU CHAPLAINS, WINSTON'S KITCHEN - \$5

FRI. 9-2 AUSTIN REGGAE ALL-STARS
+ SPECIAL GUESTS & WINSTON'S KITCHEN - \$5

SAT. 9-3 THE COSMIC COWBOYZ

SUN. 9-4 LA CASTANEDA & MORE

FRI. 9-9 LOS KURADOS & MORE

SAT. 9-10 TAMIR BRYANT & FRIENDS

Austin's Good Vibes Club Since 1991

515 E. 6TH ST. AUSTIN, TX 78701
PRE-SALE TICKETS & BOOKING INFO:
WWW.FLAMINGOCANTINA.COM

KEEP AUSTIN REAL

Support free press. Advertise with us.

THE AUSTIN CHRONICLE

AUSTINCHRONICLE.COM/EVENTS

SUBMISSION INSTRUCTIONS: MUSIC LISTINGS DEADLINE IS MONDAY, 9AM, FOR THAT WEEK'S ISSUE, PUBLISHED ON THURSDAY. PLEASE INDICATE ROADSHOWS AND RESIDENCIES. SEND VENUE NAME, ADDRESS, PHONE NUMBER, ACTS, AND START TIMES TO CLUBS@AUSTINCHRONICLE.COM.

Southpark Meadows Southpark Meadows Through the Decades w/ Micah Shalom (7:00) 📍

Speakeasy Chandler & the Bings (9:30)

Spokesman Abe the Ambassador (6:00)

Still Austin Shadow Band Trio (6:00)

Stubb's The Kid Laroi, ericdoa (8:00) 📍 📍

Suds Red Dirt Jubilee (6:30)

Summit Rooftop Luniz, CRG (10:00) 📍

Swan Dive A Trip to Mars day one w/ Sick, Sudden Deaf, Sodomy Cop, Hollow Skulls (9:30) 📍

Three Legged Goat Morgan Obenhaus, Jake Riggs (6:00)

Valhalla The Pinky Rings, Dream Reamer, King Clam, Transy Warhol (9:30) 📍 📍

Veracruz All Natural Rey Arteaga, Son y No Son (8:00)

Vincent's on the Lake Shakedown (9:00)

Vista Brewing BettySoo (6:00) 📍

The Water Tank Angelyn (6:00)

Waterloo Records Jeremy Nail (record signing) (5:00) 📍

The White Horse JD Clark & the Stuck in the Mud Band, Pearlsnap Playboys, Rob Leines (8:00) 📍, Jacob Alan Jaeger (5:30)

Wild West Steph Cash (9:00)

SATURDAY 8/27

04 Center Butch Hancock (8:00) 📍 📍

3ten ACL Live Skyrocket! (8:30)

The ABGB Texas String Assembly (9:00)

Anderson Mill Pub Hanna Barakat, Shelly Knight, Tarantula Mountain (9:00)

Angel's Icehouse Amber Lucille (8:00), JoAnna Lee (6:00) 📍

Antone's Fabulous Thunderbirds, W.C. Clark (8:00) 📍

Armadillo Den Jac Carson (8:00)

Baker Street The Weak Knights (9:00)

Banger's Shadow Band (7:00), Bakersfield TX (3:00)

Beerburg Brewing James Hearne (2:00)

Bell Springs Winery Dylan Tanner (2:00)

Black Sparrow Blaggards (8:00)

The Boat Blazin Kane (8:00)

Brass Tap Round Rock Bruised Sinatra (9:00)

Broken Spoke Alvin Crow (9:00), Paula Russell (6:00)

Buck's Backyard Dexter & the Moonrocks (11:00)

Buddy's Place Hillbilly National Bank (8:00)

Bugle Boy Cari Hutson (8:00)

Butterfly Bar Nomads (7:00)

C-Boy's Tomar & the FCs (10:00) 📍, Briscoe (8:00)

Carousel Lounge Stardust Vinyl (9:00), House Party Band (7:00), Josh Koons (5:30)

Celis Brewery Vin Mott Blues Band (5:00)

Central Machine Works Brian Scartocci, Anders Drerup (6:00)

Central Market North NAJO (5:30) 📍

Central Market South Cienfuegos (6:30) 📍

Cheatham St. Parker Ryan (8:00) 📍

Chess Club White Lightning Company, Altamesa, Witches Exist (10:00)

Circuit of the Americas Jack Johnson, Ziggy Marley (7:15) 📍

Club Miami ATX Yailin la Más Viral (10:00) 📍 📍

Come & Take It Live CannaRock w/ Chaw, Relevant Saints (11:00am) 📍

The Concourse Project Tchami (9:00) 📍

Congress Avenue Bridge Bat Fest w/ Toadies, Chamillionaire, Kolby Cooper, the Unlikely Candidates, Lil' Flip, the Nixons, Bun B, Slim Thug, Blackillac, Logan Jahnke, DJ Shaynea (3:00) 📍 📍

Continental Club Wrongbird, the Watters (EP release) (10:00), Earl Poole Ball (3:30)

Continental Club Gallery Josh Perdue (10:30), Briscoe (8:30)

Copper Shot Distillery Them That Know (7:00)

Coupland Dancehall Clay Hollis, Joey Greer (8:30) 📍

Devil May Care Gamma (9:00)

Dann's Depot Danny Britt & Red Dawg (9:00)

Dreamland Ben Zuniga Band (7:00)

Driskill Bar Cornell Hurd Band (8:00)

El Mercado The Eggmen (7:00) 📍

The Electric Church See You in Health benefiting the Lilith Fund w/ Sludge, Temprix-13, Vision Arcade, the Quadroholics, Giraffe Neck, DJ Malligator (6:00) 📍 📍

Elephant Room The Brew (9:00)

The Far Out For the Love of SIMS benefiting SIMS Foundation w/ Chief Cleopatra, Akina Adderley, Eli Arbor (7:00)

Fareground Adam Johnson Band (6:30)

Feels So Good Tunnel Vision w/ Favor, Daydreamer, Sweet Encounters, Wolfman's Brother, Apollo, Midnight Butterfly, Live Another Day, Lila & Sofia (6:00) 📍

Fitzhugh Brewing Mark Campbell (2:00)

Flamingo Cantina Turbulence, Tydal Kamau, Teflon (9:00) 📍

Garrison Brothers Distillery Homer Whisenant (1:00)

Geraldine's Elijah Zane (10:00), Jazz brunch w/ Daniel Dufour (11:30am)

Giddy Ups Mark Weber y Los Cuernos (8:30) 📍

The Green Jay Texas Exiles (single release), Erica Michelle (live album release), Beatnik Bandits (9:00)

CONTINUED ON P.58



Austin City Limits Live at The Moody Theater

Tickets and show information at acllive.com » Located at 310 W Willie Nelson Blvd

ON SALE FRIDAY, 10AM

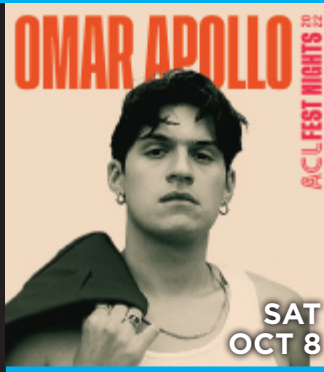

THIS WEEKEND



COMING SOON



An Intimate Concert Venue
Downstairs From ACL Live
3TENaustin.com

ON SALE FRIDAY, 10AM



THIS WKND



COMING SOON



All dates, acts, & ticket prices subject to change without notice. All tickets subject to applicable service charges.

SUPPORT FREE PRESS

Please consider supporting *The Austin Chronicle*. For just a few bucks, you can help us keep delivering the news.

[AUSTINCHRONICLE.COM](http://austinchronicle.com) / **SUPPORT**



FROM SATURDAY

Greene Hall Bri Bagwell (album release), Jaret Ray Reddick (9:00) 🎧🎧🎧, Flat Top Jones (1:00) 🎧

Guero's The Alibis, Ian Stewart, Henri Herbert (2:30)

Hanovers Teachers Night w/ Keep on Truckin' (9:00)

The Happy Cow Haywire (8:30)

Hays City Store Gary Kyle (7:00) 🎧

Hole in the Wall Montclair (single release), Hanover, Madison Baker, Rococo Disco, Yardsale! (8:00)

Hotel Vegas Borzoi, Celebrity Death Slot Machine, Dimitri, Leche (9:30) 🎧

Hudson's on Mercer All Star Jam w/ Natasha Hudson, Chad Hudson, Joey Resendis (9:00)

Independence Brewing Summer Sesh w/ Mothership, Commodus (album release), High Desert Queen, Descendants of Erdrick, Wild Pleasures, Stone Nomads (3:00) 🎧

Indian Roller Salsa Slam w/ DJ Fenix (9:00), Loteria (6:00), DJ Shewoff (5:00)

Infamous Brewing Skeeter & the Stump Thumpers (6:00)

Iron Wolf Ranch Chuck Wimer (2:00) 🎧

Jester King Brewery Sons of Kitsch (7:00)

Kenny Dorham's Backyard System Positif, Gidi Agbeko & the Roots (8:00) 🎧🎧

Kick Butt Coffee Local Austin showcase w/ Worm Suicide (11:20), Rahmus (10:30), Shitty Advice (9:40), One Shot Down (8:50), Rebel Flesh (8:00), the Awful Lot (7:10), Nematoads (6:20), Bill Godfrey (5:30), Randall Ward Group (4:40), Tony Frische (3:45) 🎧🎧

Knomad Bar Pfisters, Gospel Truth, Plastikey (9:00)

Lake Austin Spa Resort Mike Gonzalez (7:30)

Lamberts The Last Jimenez (8:00)

Las Palomas S7VEN (6:00) 🎧

Last Chance Libby & the Loveless (9:00)

Little Longhorn Modern Don Juans (9:00), the Hens (6:00)

Lone Star Court Hourglass (8:00)

Long Center KUTX & KAZI present Summer Jam w/ Geto Gala, Anastasia Hera & the Heroes, Moody Bank\$, Tribe Mafia, Confucius Jones & Fresh Knight of the Breaks (hosts) (6:30) 🎧

Long Play Lounge East Gamer Sloan, Dinner With Matt Gilchrest (9:00)

The Lost Well We Are the Asteroid, the Flood, Sex Pümp (9:00) 🎧

The Lucky Rabbit The Stooch Band (9:00), Tylor Brandon (6:00), James Parker (2:00)

Madrone Coffee Casey Joe Collins (10:00am) 🎧

Maggie Mae's Leander Craig Marshall (8:00)

Mala Santa Larry Hernandez, Seto Vargas y Sus Calentanos (9:00) 🎧

Mean Eyed Cat End of summer party w/ Bruce Smith (2:00)

Meanwhile Brewing Co. Chris Bell & Emilio Arsuaga (7:00)

Mercer Dancehall Bob Appel (8:00)

Mohawk Intent, Condemned Unit, Detox, User Unauthorized, Molly Ringworm [inside] (10:00) 🎧🎧, Brownout, Trouble in the Streets, JeTexas [outside] (8:00) 🎧

Moody Amphitheater Gloria Trevi (8:00) 🎧

Moontower Saloon Electric Hunter (9:00)

Mozart's EyeOurEl (8:30), Poet Hawkins (5:00), Shadow Band Trio (1:30), A.C.III Jazz Trio (10:00am) 🎧

Neighbor's Adam & the Crow Daddies (7:30)

NeWorldDeli Mark Viator & Susan Maxey (7:00)

Parish Fucked Up, the Umbrellas (8:00) 🎧

Parker Jazz Club Great American Songbook Selections (9:30, 7:30)

The Parlor The Hormones, Half As Bad, Dropped Out (4:00)

Parmer Lane Tavern Honey Punch (9:00)

The Pershing Magnifico (8:00)

Planet Rock Dysfunkshun Junkshun (8:30)

Poodies Choctaw Wildfire (10:30), Kim Meeks & Her Bad Habits (8:00), Ricke Brothers (6:00)

The Porch Happen Twice Takeover (10:00), B(eats) brunch w/ Chief & the Doomsday Device (noon)

Radio Coffee & Beer Dog Island, Virginia Creeper (8:00)

The Railhouse The Summer Bash w/ Ricky Naranjo y Los Gamblers, J.R. Gomez y Los Conjuntos Bandits, Broken Arrow, Jesse the Jammer, DJ Fly, DJ Nitrous (5:00) 🎧

Riley's Tavern Billy Dee Band (8:00)

Roughhouse Brewing Brian Wolff (6:00)

Sagebrush Sentimental Family Band, Jake Penrod, Wild Fitz (7:00)

Sahara Lounge Zoumoundchi, Frederico7 y los Primes, Afro Jazz (7:00)

Sam's Town Point Emily Nenni (11:00), Friends of Lazy Lester (8:00) 🎧

San Jac Saloon Kassi Gilbert [upstairs] (10:00), Joe Vega (3:00), Aaron Navarro Band (10:00), Bron Burbank (6:00)

Saxon Pub Paul Val (10:00), Guy Forsyth Band (8:00), Raising Cale (J.J. Cale tribute) (6:00)

Scholz Garten GrahamStock benefiting the Other Ones Foundation w/ Jane Leo, Matt the Electrician & Southpaw Jones, Restos, Ali Holder, South Austin Jug Band, Suzanna Choffel, Graham Wilkinson, Aubrey Hays, Billy Broom (4:00) 🎧🎧

Shooters Cedar Park Chris Hoff & the Hill Country Half-Timers (9:00)

Shooters North Dead Love Club (9:00)

Shore Raw Bar Julia Slim Trio (7:30)

Sidcar Tasting Room Dylan Tanner (6:00)

Skylark Lounge Soul Man Sam & the SMS Band (10:00), Oscar Ornelas (8:00), Joanna Howerton & Michael Cross (6:00)

Slackers The Way Down (6:00)

Smokin Beauty Welsh Avenue, Danny Despicable, Of the Roses (9:00)

Soundspace at Captain Quack's Con Man, Harry Zimm, Matthew McNeal (8:00) 🎧

Speakeasy Lonestar Souvenirs (9:30)

Summit Rooftop Tommie Sunshine (10:00)

Swan Dive A Trip to Mars day two w/ Billy Glitter, Favor, Dream Reamer, Merry Cherry (9:30) 🎧

Texas Keeper Cidery Much 2 Much (4:00)

Three Legged Goat Mandy Prater, Kaye Reznick (6:00)

Treaty Oak Distilling Mike & the Burnalls (6:00)

Valhalla Martyred, Vulture Christ, Unnecessary Surgery (10:00)

Vincent's on the Lake Hair Metal Giants (9:00), Billy Cage (2:00)

The Water Tank The Balls (7:00)

The White Horse David Touchton, Them Duquaines, Dave Inslay (8:00), Shad Blair (5:30)

Whitewater Amphitheater Charley Crockett, Emily Scott Robinson, Greyhounds (8:00) 🎧🎧

Willie's Joint LC Rocks (9:00)

SUNDAY 8/28

The ABGB Georgia Parker (4:00)

ACL Live Robert Earl Keen, Todd Snider (8:00) 🎧🎧

Angel's Icehouse Music, Mary's, & Mosas w/ Shawn Mathews (6:00) 🎧

Armadillo Den Anders Drerup (6:00)

The Ballroom The Shake, Trace of Lime (7:00)

Banger's David Winsman Trio (2:00), Fausto/Faustito (10:00am)

Beerbug Brewing Luis Ibanez (2:30), Beth Lee (11:30am)

Bell Springs Winery London Baileigh (2:00)

The Boat Zack Varner Blues Band (6:30)

Butterfly Bar Tony Grant (8:00), Sp_aces (6:30)

C-Boy's Mike & the Burnalls (10:00), Imperial Starlighters (7:30), Chicken \$#!+ Bingo w/ the Derailers (3:30)

Colis Brewery Bruised Sinatra (2:00)

Central Machine Works Brandon Padier & Black Gold (6:00) 🎧

Central Market South Beautiful Phnix Trio (noon) 🎧

Cherrywood Coffeehouse Strawberry Yops (10:00am) 🎧🎧

Circuit of the Americas Kidz Bop Live (4:00) 🎧

Club Carnaval Ladrón, Los Tiranos del Norte, Los Caminantes HN, José Diosdado y su Viento Sol USA (9:00) 🎧

Come & Take It Live Monuments, Essenger, Sammy Boller, the Ansible, Aerial (6:00) 🎧🎧

Continental Club Willie Pipkin & Friends (9:30), Heybale! (6:30), Marshal Hood (2:30)

Desert Door Meagan Tubb & Shady People (2:00)

Driskill Bar Bourbon & Beth (7:00)

El Mercado Leeann Atherton (11:30am) 🎧

Elephant Room Kevin Lovejoy Trio (9:00)

Emo's Perturbator, Health, Street Sects (7:00) 🎧🎧

Family Business Beer Co. Belldiver (2:00)

Fareground Mark Stone (6:30)

Geraldine's Jazz brunch w/ Michael Hale Trio (11:30am)

Giddy Ups OTB Karaoke w/ Big John (8:30), Mark Willenborg & the Shufflehawks (4:00)

Greene Hall Henri Herbert Band (5:00), Seth James Walker & Western Union Man (12:30) 🎧

Guero's Chicken Strut (3:00)

Half Step PhotoFunktion jam (8:00)

Hanovers Care 4 Conrad benefit show w/ Legend of Ozz, Big Balls, LC Rocks, American Gypsy Band, Broken AF, Brother Stone (3:00)

Hays City Store Ghost Jam Players (6:00)

Hole in the Wall Wilkinson's Quartet, Haydon Hoodoo, Billy Mockingbird (8:00)

Hotel Vegas Slomo Drags, A. Sinclair, Burgess Meredith (10:00)

Indian Roller Blues jam w/ Ted Hall (6:00)

Infamous Brewing Ella Reid (3:30)

Jester King Brewery Tiger Alley (5:00), Chris Gebhard (noon)

Jo's (S. Congress) Warren Hood & the Jo's House Band (12:30) 🎧

Kenny Dorham's Backyard Family jam (5:00) 🎧

King Bee Michael Hale Trio feat. Mac McIntosh (9:00)

Little Longhorn Original Home of Chicken Shit Bingo w/ Jason Roberts Band (4:00)

Long Play Lounge East Blake Whitmire Band (9:00)

The Lucky Rabbit Will Southern (2:00)

Madrone Coffee Open mic (4:00), Joanna Howerton & Michael Cross (10:00am)

Meanwhile Brewing Co. Birthday Suit (6:30)

Mercer Dancehall Monte Good (3:00)

Mohawk American Vines, Big Loser, Collective Dreams, Loafer's Bend [inside] (8:00) 🎧🎧

Mozart's Rileyann (8:30), Erica Michelle (5:00), Nick Austin (1:30), Selmer's Arch (10:00am) 🎧

Native Hostel Something Liquid (drum & bass) w/ ML, Chris T, Blang, Duhrdy (10:00)

Neighbor's Ryan Paul Davis (5:00)

NeWorldDeli Cheryl Cawood & Kerry Keen (2:00) 🎧

Oasis Brewing Cade Mower (2:00)

Oskar Blues Brewery CTBA Sunday bluegrass jam (3:00)

Parker Jazz Club Cole Porter Songbook (7:30, 5:30)

The Parlor Skatenigs (4:00)

Poodies Arkansas Dave (7:30), Andrea Marie (4:00)

The Porch Open mic w/ Vance Loggins (8:00), HalleyAnna Finlay song swap (3:00)

Riley's Tavern Picker's Circle w/ Bo Porter (4:00)

Roughhouse Brewing Nick Taylor (noon)

Rustic Tap Nick Swift (6:00)

Sagebrush Guitar Grady, the Mellows (9:00)

Sam's Town Point Cocktail Steel w/ Rose Sinclair (7:00), Girl Guitar showcase (1:00)

San Jac Saloon Jake DeCasper (9:00), Aaron Navarro (5:00)

Saxon Pub The Resentments (7:30), Deann René (5:30)

Shore Raw Bar Shore Sunday jam session w/ Big John Mills (6:00), Jazz brunch w/ Rachel Turgoose Quartet (noon)

Skylark Lounge Soul Man Sam & the SMS Band (8:00), Willie D & the Hip Pockets (6:00)

Smokin Beauty Erik Hanchey (6:00)

South Congress Hotel Groove Army (4:30)

Speakeasy Matt Boland (6:00)

Suds Bluegrass jam (noon)

Texas Keeper Cidery The Merles (3:00)

Twin Creeks Icehouse Open mic night (8:00)

Vincent's on the Lake JenDuo (11:00am)

Vista Brewing Sentimental Family Band (noon) 🎧

Waterloo Records Madam Radar (record signing) (3:00) 🎧

The White Horse Armadillo Road, Silo Road (8:00)

MONDAY 8/29

ACL Live Robert Earl Keen, Todd Snider (8:00) 🎧🎧

Antone's Soul Man Sam & the SMS Band, Lindsay Beaver & Brad Stivers (8:00)

Armadillo Den Stray Dawg & the Wolves (7:00)

Butterfly Bar Tony Grant (8:00), Mike Kiddoo (6:30)

Buzz Mill Open mic w/ Cole McDonnell & Chris Turpen (8:00)

C-Boy's Rosie Flores R&R Trio (10:00), Andrea Magee (6:30)

Continental Club Dale Watson (10:15), Teddy & the Tall Tops (6:30)

Continental Club Gallery Michael Hale Trio (10:30), Church on Monday w/ Elias Haslanger & Dr. James Polk (8:30)

Donn's Depot Chris Gage (8:30)

Driskill Bar Brian Wolff (7:00)

El Mercado The Monday Night Supper Club song swap w/ Pat Byrne, Ben Jones, & Barbara Nesbitt (7:00) 🎧

Elephant Room Monday Night Jazz Jam w/ Michael Mordecai (9:00), Austin Jazz Band (7:00)

The Far Out Motown Mondays w/ Matchmaker Band (7:30)

Friends Jac Carson (noon)

Geraldine's Drew Davis Duo (8:00)

Giddy Ups Big Joe & the Bigger in Texas Band (7:00)

Greene Hall Bo Porter (6:00) 🎧

Hays City Store W.C. Clark (6:00)

Hole in the Wall Scott Ballew, Ryan Sambol, JeTexas (9:00)

Hotel Vegas Sterling Morrison birthday party & tribute w/ Jake Garcia, Nolan Potter, Gus Baldwin & Friends (10:00)

Kenny Dorham's Backyard Blue Monday Blues Jam (7:00) 🎧

The Lucky Rabbit George Gurganus (6:00)

Mohawk Queen Jane, Secret Garden, Fools Sick [inside] (10:00) 🎧, Helado Negro, Kaina [outside] (7:30) 🎧🎧

NeWorldDeli Open mic (7:00)

Poodies Songwriters showcase w/ Matt Caldwell, Michael Myers (6:30)

Radio Coffee & Beer Bluegrass Night (7:00)

The Railhouse Luke Daniel (7:00)

Rustic Tap Keith, Mike, & Johnny song swap (7:00)

Sagebrush Sadistic Force, Sabbath Crow, Now It's Dark (9:00)

Sam's Town Point Little Elmore Reed Band (10:00), two-step dance lessons w/ Double or Nothing (8:30), Steel Monday w/ John Russell (7:00)

San Jac Saloon Will Southern (9:00), Aaron Navarro (5:00)

Saxon Pub Lonelyland (8:30), Brian Pounds (6:00)

Speakeasy Open mic w/ Raul Ochoa (8:00)

Spokesman Beat Sessions Vol. 35 (8:00)

Victory Grill Blue Monday Blues Jam (8:00)

The White Horse Brian Scartocci, Adam Johnson (8:00)

TUESDAY 8/30

ACL Live Cuco, Dannylux (8:00) 🎧🎧

Antone's Sly Curtis, Goldie Pipes (8:00)

Armadillo Den Jonathan Matthews (7:00)

The Ballroom Dmitri, Middle Sattre, Rileyann (8:00) 🎧

Broken Spoke Two-Steppin' Tuesday w/ Weldon Henson (8:00), Western Express (6:00)

C-Boy's Grooveline Horns, Sketch (9:30), 8½ Souvenirs (6:30)

Continental Club The Last Jimenez, James McMurtry (10:00), Carolyn Wonderland & Shelley King (6:30)

Continental Club Gallery LaQuin Lay (10:30) 🔄

Donn's Depot Grouchy Like Riley (8:30)

Driskill Bar Massimo Gerosa (7:00)

El Mercado John Arthur Martinez (7:00) 📍

Elephant Room Paul Deemer Quintet ft. Trevor Turia (9:00), Sarah Sharp Quartet (6:00)

Empire Control Room Flasher, On Being an Angel, A.L. West [control room] (8:00) 📍

The Far Out The Screamlongs, Foxtrot Unicorn (7:00)

Friends Hunter Walkup, Lewis Christian (7:30)

Geraldine's Sheridan Reed (8:00)

Giddy Ups Breck's Open Blues Jam (7:45), W.C. Clark (5:00)

Gruene Hall Slim Bawb (6:00) 📍

Half Step Michael Hale Trio feat. Mac McIntosh (9:00)

Hays City Store April Lee Duo (6:00) 📍

Hole in the Wall We Are Blood Bays, Opposite Day (9:00)

Hotel Vegas Marry Cherry, Hans Condor, T.F.S. (10:00) 📍

King Bee Bluesdays Tuesdays w/ Michael Brodnax (8:00)

Little Longhorn Fingerpistol (8:00), two-step dance lessons w/ Wyatt & Megan of Hill Country Two Step (7:00)

Long Play Lounge East Jacob Wise's Jazz Jam (9:00)

The Lucky Rabbit Manzy Lowry (6:00)

Meanwhile Brewing Co. Michael Paul Lawson (7:00) 📍

Mohawk Acaustix, Algara, Damak, Scorched Earth, Funhouse [inside] (9:00) 📍📍, Peter Hook & the Light [outside] (7:30) 📍📍📍

Moody Center Ghost, Mastadon, Spiritbox (7:00) 📍

NeWorDeli Beatle Bash w/ the Eggmen (6:30)

Oskar Blues Brewery Open Mic Tuesdays w/ Kuna Lakai (5:15)

Parker Jazz Club Parker Jazz Club House Band (7:30)

Poodies Austin Mayse & Jake Martin (8:00), the Troubadillos (5:00)

The Porch Dave Sims & the Hot Pipes (9:00)

Rustic Tap Ruby Dice (7:00)

Sagebrush Rock Step Releators (9:00), beginner swing dance lessons w/ Four on the Floor (8:00)

Sam's Town Point Rance May & the Coyotes (10:00)

San Jac Saloon Pat Vaughan (5:00), Aaron Navarro (9:00)

Saxon Pub Arkansas Dave (10:00), Ben Jones (8:00), David Grissom (6:00)

Speakeasy Anthony Lux (8:00)

The Water Tank Musicians Jam hosted by Ernie Welter & Shoot From the Hip (8:00)

The White Horse The Mellows, Blake Whitmire Band, Devin Jake (9:00)

Antone's The Fixx, Royston Langdon (8:00) 📍

The Ballroom Weavr, Death Party, Hollow Skulls (7:00) 📍

Bar 620 Andrea Marie Songswap Series (7:00)

Broken Spoke Ian Stewart (9:00), Manny Velazquez (6:00)

Buck's Backyard The Rowdies (8:00)

Buddy's Place Cade Baccus (7:00)

Butterfly Bar Magnolia Kids (8:00)

C-Boy's JeTexas, Pierson Saxon (10:00), Moeller Brothers (6:30)

Carousel Lounge Quasar Cycles (8:00), Blair Brown & the Western Hearts (7:00)

Cedar Street Courtyard The Nightwows (9:30)

Cherrywood Coffeehouse Lee Redfield (8:00) 📍

Chez Zee Margaret Slovak (6:00) 📍

Circuit of the Americas LANY, Surfaces (6:30) 📍

Continental Club Snakes of Central Texas, Jon Dee Graham, William Harries Graham (9:30), Allisen & the Wy's Guys (6:30)

Continental Club Gallery The Brannen & Red Show (10:30), James McMurtry (8:30)

Donn's Depot Frank Cavitt & the Honky-Tonk Doctors (8:30)

Draylen Mason Studio Atomic (8:00) 📍📍

Driskill Bar Bruce Smith (7:00)

Elephant Room John Mills Times Ten (9:00), Bree Romeo Quartet (6:00)

The Far Out Danilo, Daddy Nat, Europa Boys (7:00)

Flamingo Cantina Dreadneck Wednesdays w/ Mau Mau Chaplains (8:30)

Friends Jennifer Harrold (11:00), Brad Stivers (7:30), Conner Stephens (noon)

Geraldine's Aubrey Hays (8:00)

The Green Jay Michael Hale Trio feat. Mac McIntosh (10:00)

Gruene Hall Adam Johnson (6:00) 📍

Guero's Texas Radio Live w/ Wyatt Weaver Band (7:00)

Half Step Canned Beets (8:30)

Hays City Store Amber Lucille (6:00)

Hole in the Wall Bacon Fat Live w/ Crocodile Tears (9:00)

Hotel Vegas Brody Price, Magic Rockers of Texas, Nick Garza's Get Along (10:00) 📍

Juliet Matt Creaton (6:00)

Little Longhorn Bakersfield TX (8:00), two-step dance lessons w/ Wyatt & Megan of Hill Country Two Step (7:00)

Long Play Lounge East Gus Miller Band (9:00)

The Lucky Rabbit Will Southern (6:00)

Mohawk Peter Hook & the Light [outside] (7:30) 📍📍📍

Monks Jazz Club Glenda Davenport Quintet (7:30)

Moody Center Kid Cudi, 070 Shake, Strick (7:00) 📍📍

NeWorDeli Marina Rocks (7:00)

Parish Holy Wire (single release), Pelvis Wrestling, TC Superstar (8:00) 📍

Parker Jazz Club The Copa Kings (7:30)

Parmer Lane Tavern Chris Max jam (9:00)

The Pershing Justin Langston (8:00)

Poodies No Bad Days open mic (8:00)

The Railhouse Karate Cowboy (8:00)

Riley's Tavern Wednesday Song Series w/ Mike Naumann (7:30)

Round Rock Tavern The Rising Sons (8:00)

Sagebrush Beth Lee, Sentimental Family Band, Tara Dente (7:00) 📍

Sahara Lounge Lonesome Nights w/ DJ Dillon, Batty Jr. (solo), Jim Campo, Lady Dan (7:00)

Sam's Town Point Guthrie Girls & the Stage Door Johnnies (10:00), Guitar Grady [inside] (8:00)

San Jac Saloon Angelynn [upstairs] (9:00), Tylor Brandon Duo (5:00)

Saxon Pub The Drakes (6:00), Scott Collins (10:00), Ben Brown (8:00)

Seareinas Monica Reyna (8:00) 📍

Shore Raw Bar Pamela Hart (6:30)

Speakeasy The Spazmatics [ballroom] (9:45)

Still Austin Lewis Christian (7:00)

Trace at the W Hotel Sound Check benefiting Austin Animal Center w/ Nick Swift (8:00)

Vincent's on the Lake Southern Angels (7:00)

The White Horse Jacob Alan Jaeger, Ellis Bullard, Tiger Alley (8:00)

Willie's Joint Bo Luna (7:00)

Looking for more?

For next week and beyond:
austinchronicle.com/events/music.

ROADSHOWS

T H U 8/25

LYLE LOVETT & HIS LARGE BAND, ACL Live

TEMPOH SLOW, Antone's

TYLOR BRANDON, Armadillo Den

CARSON JEFFREY, Cheatham St.

DARWIN'S FINCHES, Chess Club

ONE REPUBLIC, NEEDTOBREATHE, Circuit of the Americas

INCANTATION, GOATWHORE, BEWITCHER, Come & Take It Live

J. WORRA, the Concourse Project

BORIS, NOTHING, Empire Control Room

TONSTARTSSBANDHT, the Far Out

LED ZEPPELIN 2, Haute Spot

GUS CLARK, the Lucky Rabbit

GIOVANNIE & THE HIRED GUNS, CANAAN BRYCE, Mavericks Dance Hall Buda

YOUNGTONES, Mohawk

SWEDISH HOUSE MAFIA, Moody Center

HELLO SEAHORSE!, Parish

EMMALINE, Parker Jazz Club

MARY-CHARLOTTE YOUNG, Riley's Tavern

RYAN FAUBER, Sahara Lounge

LA BANDA 614, Seareinas

BUSCHY, AX, AEVUM, LEØ, Summit Rooftop

HENRY FONG, ARIUS, the Venue ATX

SUICIDEBOYS, SKI MASK THE SLUMP GOD, MAXO KREAM, \$NOT, Circuit of the Americas

CALIBRE 50, BANDA CARNAVAL, CUARTO DE MILLA, Coliseum

NO MANA, the Concourse Project

CODY HIBBARD, JOSHUA HEDLEY, Coupland Dancehall

SKRATCH BASTID, MILES MEDINA, Devil May Care

VAN FULL OF NUNS, HOUSE PARTIES, THE IDLE KIND, Empire Control Room

ANDY DAVIS, the Far Out

LEMON DISCO, Flamingo Cantina

MAX STALLING, ETHAN HANSON, Gruene Hall

DENIM & LEATHER, Hanovers

DEAD BILLIONAIRES, Hole in the Wall

BRAINSTORY, Hotel Vegas

TEMPTRESS, the Lost Well

DEATH BELLS, SMIRK, Mohawk

KANE BROWN, Moody Center

THE KID LAROI, ERICDOA, Stubb's

LUNIZ, Summit Rooftop

KING CLAM, Valhalla

ROB LEINES, the White Horse

S A T 8/27

BUTCH HANCOCK, 04 Center

FABULOUS THUNDERBIRDS, Antone's

PARKER RYAN, Cheatham St.

JACK JOHNSON, ZIGGY MARLEY, Circuit of the Americas

YAILIN LA MÁS VIRAL, Club Miami ATX

CHAW, RELEVANT SAINTS, Come & Take It Live

S U N 8/28

ROBERT EARL KEEN, TODD SNIDER, ACL Live

BRANDON PADIER & BLACK GOLD, Central Machine Works

KIDZ BOP LIVE, Circuit of the Americas

LADRÓN, LOS TIRANOS DEL NORTE, LOS CAMINANTES HN, JOSÉ DIOSDADO Y SU VIENTO SOL USA, Club Carnaval

ESSENGER, SAMMY BOLLER, Come & Take It Live

PERTURBATOR, HEALTH, Emo's

COLLECTIVE DREAMS, Mohawk

CHERYL CAWOOD, NeWorDeli

M O N 8/29

ROBERT EARL KEEN, TODD SNIDER, ACL Live

HELADO NEGRO, KAINA, Mohawk

T U E 8/30

CUCO, DANNYLUX, ACL Live

FLASHER, Empire Control Room

APRIL LEE, Hays City Store

HANS CONDOR, Hotel Vegas

MICHAEL PAUL LAWSON, Meanwhile Brewing Co.

PETER HOOK & THE LIGHT, ALGARA, Mohawk

GHOST, MASTADON, SPIRITBOX, Moody Center

W E D 8/31

THE FIXX, ROYSTON LANGDON, Antone's

DEATH PARTY, the Ballroom

LANY, SURFACES, Circuit of the Americas

ATOMIC, Draylen Mason Studio

BRODY PRICE, Hotel Vegas

PETER HOOK & THE LIGHT, Mohawk

KID CUDI, 070 SHAKE, STRICK, Moody Center

TARA DENTE, Sagebrush

MONICA REYNA, Seareinas

SAHARA LOUNGE

EVERY SAT 7PM-2AM

DANCE

Africa Night

Best Live Afrobeat Band

ZOU MOUNTCHI & SPECIAL GUEST BANDS

2020 & 2022 AUSTIN MUSIC AWARDS BEST RESIDENCY!

FREE PARKING

AFRICAN DINNERS WITH VEGAN OPTIONS

SEATING INSIDE OR OUTDOOR

DIVERSE CROWD

1103 WOODVILLE RD
 KEMERLOUNGE.COM

SUPPORT FREE PRESS

Please consider supporting *The Austin Chronicle*. For just a few bucks, you can help us keep delivering the news.

THE AUSTIN CHRONICLE

AUSTINCHRONICLE.COM/SUPPORT

The Doll House
 Lingerie Modeling & Adult Boutique

Now Hiring

1/2 OFF DOOR FEE!
 EXPIRES 9/6/22

183 Spicewood Springs Rd. (East Anderson Mill @ 183 frontage & Roxie)

512/988-1246
 13205 HWY. 183 NORTH

📍 ALL AGES VENUE 📍 ROADSHOW 📍 RECOMMENDED

THE Luv Doc



"A THIN MUSTACHE"

Dear Luv Doc,

My husband has always been an unconventional guy, but as he's gotten older, he has become even more adventurous in how he dresses, styles his hair, etc. For the last few years he had shoulder-length hair. Before that he shaved his head for a long while. Most recently, he has been experimenting with facial hair ... first a full beard, then goatee, then a mustache which I didn't mind too much, but now he has shaved into a very thin, above-the-lip, John Waters-style mustache that totally creeps me out. I can barely look at him, much less feel attracted. I have been avoiding going out to dinner with him or places in public because I am so embarrassed. And yes, I have told him it isn't a look I prefer, but he can be very obstinate so I haven't pushed it. I would like you to weigh in on this because I am at my wit's end. How do I get him to shave it?
— Mrs. Waters

Americans pride themselves on their rugged individualism and self-reliance, and yet we do surprisingly well in team sports and mob mentality. We don't really embrace mysterious loners as much as we like to pretend. The real truth of American culture is that the lone drifter who rode into town had a fairly decent chance of winding up in a shallow, unmarked grave just outside city limits. Exponentiate those odds if he walked in barefoot like Caine or bare-assed and feathered on the back of an Appaloosa. Maybe that was the reason Clint Eastwood's character in Sergio Leone's trilogy was simply called "The Man With No Name." I don't know if Sergio Leone had a soft spot for irony, but it sure seems like it.

Nowadays, Americans are a slightly more tolerant lot. For instance: In 2016 every goddamned state in the South elected a thrice-divorced, silver-spoon-fed, Yankee attention whore with no morals whatsoever. Now, I will grant that Southerners ... and Americans in general ... aren't exactly regarded as deep thinkers, but even for most astute social scientists, Trump's election was, and continues to be, a bit of a head-scratcher. How could nearly half of America be such unrepentant chumps? I think it was simple. The chumps reached a critical mass. At the exact moment when America needed to rely on its most well-promoted asset — the free-thinking, rugged individualists who couldn't be swayed by mob rule ... the Atticus Finches, the Jett Rinks, the Dagny Taggarts ... all seemed to fade into the woodwork — or even worse, put on MAGA hats and join the chants of, "Build that wall!" There were some notable and laudable exceptions, yes, but they were and continue to be excoriated by the mob of "rugged individualists" who elected the worst president in American history.

So, while I will stop short of calling your husband a hero, true iconoclasy in America is in woefully short supply. It takes a huge amount of bravery to wear a mustache that might earn you a savage beat-down just for hanging out near a playscape, and while I will admit that I, too, get a Snake Farm shudder when I encounter that type of mustache on anyone not actively engaged in swashbuckling, belting out "Tutti Frutti," or basically telling Scarlett O'Hara to go fuck herself, you have to admire the chutzpah. That is some serious Liberace gangster type shit. It's a mustache that says, "I give exactly zero fucks what you think." A thin mustache is the stained sweatpants of facial hair. If you're going to rock that look you better bring something else to the table. Something awe inspiring ... magnificent. At the very least the script for *Hairspray*.

All that said, marriage is a partnership. It demands a certain amount of compromise and communication to work effectively. I highly recommend that you communicate to your husband in very strong and specific language your dislike of his current facial hair choice. Let him know you are embarrassed to be seen in public with him and that while you encourage him to express his individuality, he needs to pick another fucking mustache because this one ain't moistening your minge. If he refuses, you're going to need to go to DEFCON 1 and Sharpie in your own pencil-thin mustache to match his. Yes, you will both look ridiculous, but at least when you're together in public people will know you're not taking it lying down.

NEED SOME ADVICE FROM THE LUV DOC? Send your questions to luvdoc@austinchronicle.com.



Mr. Smarty Pants Knows

Musician Billy Ocean has three lungs. The third lung is an extra pulmonary node central to his medically normal lungs.

Modern-day root beer contains wintergreen and vanilla, as well as trace amounts of ginger, licorice, anise, juniper berries, and dandelion.

Adolf Hitler frustrated his dentist Hugo Johannes Blaschke with delayed appointments, being careless about dental hygiene, and only calling for care when he was in pain. Hitler had bad breath due to his dental problems.

When animals such as squirrels or dogs try to cool off by flattening out their bodies so their bellies touch the ground and their legs are stretched out, it's called "splotting."

The 1966 dystopian novel *Soylent Green* was set in 2022.

Above is information that Mr. Smarty Pants read in a book, a magazine, or the newspaper; heard on the radio; saw on television; or overheard at a party. Got facts? Write to Mr. Smarty Pants at the *Chronicle*, or email mrpants@austinchronicle.com.

COMICS

Eyebeam

by Sam Hurt

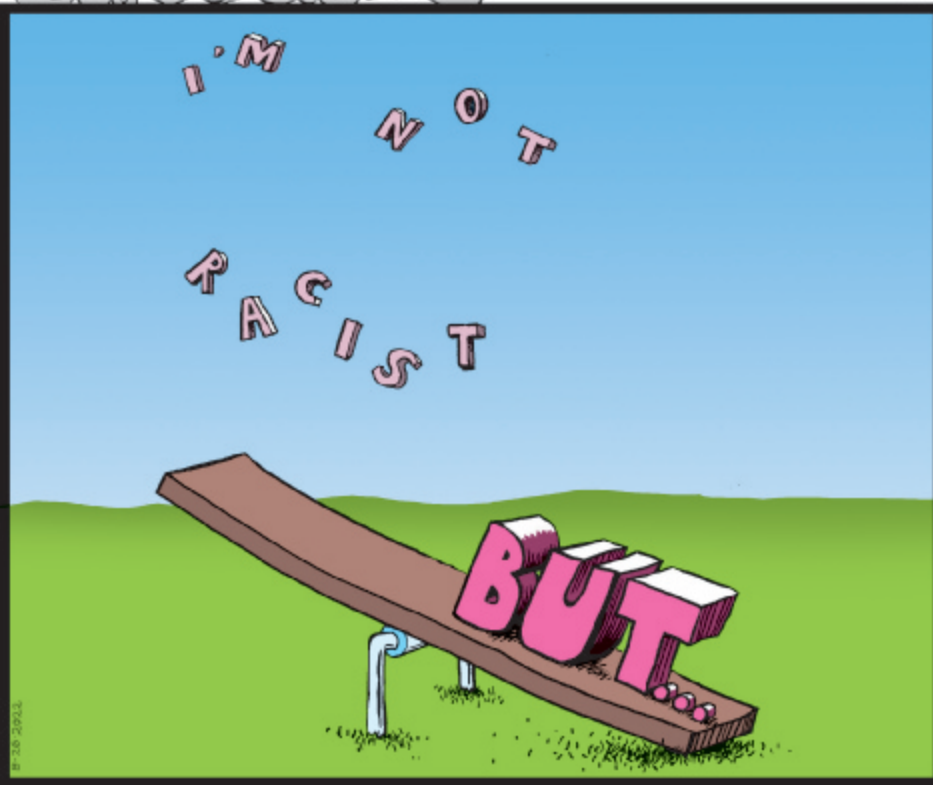

COMPUTER/TECHNICAL

ACCOUNT SPECIALIST

To apply, send resume to 3423@google.com. Must reference Job Code # below: Account Specialist (Austin, TX) Perform market research & technical analysis in connection w/ growing Google products & services. **Job Code: 1615.63499** Exp Inc: Oracle, SAP/Arriba, SalesForce, Concur, & Auction tools; supporting stakeholders & businesses to better understand legislation & local/regional laws; process consulting, stakeholder engagement, data/info mgmt, & process design analysis; project mgmt; & supplier analysis, cost driver analysis, & supplier mgmt. Position reports to the Google AUS office & may allow for partial telecommuting.

CONSULTANT, PRODUCT MARKETING

Dell USA LP is seeking a Consultant, Product Marketing at our Round Rock, TX facility and can work remotely. Must be fluent in oral and written Spanish. Responsible for acting as the organizational expert and speaker of choice within Dell Monitors and Client Peripherals solutions for Latin America. Drives the development and execution of Dell Monitors and Client Peripherals Go-to-Market Strategy for Latin America Market. Req. 002082S. To be considered for the opening, please send resume with requisition number to: jobs_dell@dell.com. No phone calls please. Workforce diversity is an essential part of Dell's commitment to quality and to the future. We encourage you to apply, whatever your race, gender, color, religion, national origin, age, disability, marital status, sexual orientation or veteran status.

BACK PAGE Advertise your product or service on the Back Page! Call 454-5765.

DATA ENGINEER

Optum Services, Inc. Data Engineer. Austin, TX. Analyze, design and build modern data solutions to support visualization of data. Mail resume: UHG GMI Recruitment at 9900 Bren Road East, MN008 R120, Minnetonka, MN 55343 and indicate applying for 22-TX-4208.

DATA ENGINEER (WARGAMING (USA), INC.

Austin, TX) Support and perform activities involved in the design and development of ETL/data integration process and programs which include data analysis, data modeling, metadata definition and management, job scheduling, and the development and testing of MapReduce code. Mail resume to: Attn: HR, Wargaming (USA), Inc., P.O. Box 1206, Chicago, IL, 60690. An EOE.

DATA SCIENTISTS

Oracle America, Inc. has openings for Data Scientists positions in Austin, Texas. Job duties include: Designs, develops and programs methods, processes, and systems to consolidate and analyze unstructured, diverse "big data" sources to generate actionable insights and solutions for client services and product enhancement. May telecommute from home. Apply by e-mailing resume to tao.l.sheng@oracle.com, referencing 385.27603. Oracle supports workforce diversity.

ENGINEERING/TECHNOLOGY

Cloudflare, Inc. has the following job opps. in Austin, TX: Data Engineer [Req. #DRE23]. Build scalable petabyte scale data lake & Entrprise Data Warehouse using modern tech stack & open source tech. Systems Engineer [Req. #SMG54]. Perform systems software devlpm. IT Business Systems Analyst [Req. #TBA79]. Dsgn solutns to add new functionality to exist'g computer systems. To apply email resumes referencing Req. # to careers@cloudflare.com

ENGINEERING/TECHNOLOGY

NVIDIA Corp in Austin, TX has an opening at various levels. Please ref code & title and send resume to: NVIDIA, 2701 San Tomas Expressway, Santa Clara, CA 95050, Attn: KC HR or send to NVIDIA-RecruitAd@nvidia.com. These positions will engage and support the design, development, and/or marketing of NVIDIA'S GPU (graphics processing units), computer graphics, AI and supercomputing for gaming, professional visualization, data centers, and various industries (automotive, transportation, healthcare and manufacturing). Sr. SW Eng (SSWENG04) Work on Data Processing Units (DPUs) and implement robust automation solutions by authoring and reviewing test plans, implementing test cases, automating tests. Sr. Architect (ARC93) Design and implement high performance Data Center architecture. Sr. ASIC Eng (SRASIC03) Design and implement RTL methodologies to enable high quality system-level IP design and robust verification at multiple environment levels, and to measure performance on the industry's leading GPUs. Sr. Verification Eng (VERE105) Build and continuously reform verification infrastructure and methodologies to meet the demands of next generation SoCs. HW Eng. Mgr (MGRHW15) Manage members of the GPU-IP formal verification team by planning, scheduling, assigning, tracking, and reviewing tasks the team is responsible for, as well as mentoring them to help them grow in their careers.

ENGINEERING/TECHNOLOGY

NVIDIA Corp in Austin, TX has an opening at various levels. Please ref code & title and send resume to: NVIDIA, 2701 San Tomas Expressway, Santa Clara, CA 95050, Attn: KC HR or send to NVIDIA-RecruitAd@nvidia.com. These positions will engage and support the design, development, and/or marketing of NVIDIA'S GPU (graphics processing units), computer graphics, AI and supercomputing for gaming, professional visualization, data centers, and various industries (automotive, transportation, healthcare and manufacturing). Dev. Tech. SW Eng (EDT08) Play a key role in all phases of

software development including coordinating features design and providing support for graphic processing unit (GPU) determinism for mainstream deep learning frameworks. Sys. SW Eng (SSWE898) Work closely with both hardware engineers and other software engineers to design, develop, and debug many functional aspects of our multimedia accelerator and mobile system-on-chip (SOC) devices. Program Mgr (PROGM33) Manage the safety aspects of the autonomous driving electronics systems by collaborating across engineering domains (SOC, platform, software and system teams) and geographic locations. ASIC Eng (ASICDE580) Verify the design and implementation of the industry's leading GPU.

HW COMMODITY SPECIALIST III

Amazon Data Services, Inc. seeks candidates for the following (multiple positions available) in Austin, TX: **HW Commodity Specialist III (Job Code 2155664)**. Lead internal engagements across supply chain, engineering, and business organizations, while diving deep into the technologies and operations both from a product and supply chain perspective. Up to 25% domestic travel. Qualified applicants should apply at: <https://www.amazon.jobs/en/> referencing the job code: 2155664.

MULTIPLE POSITIONS

To apply, send resume to 3423@google.com. Must reference Job Code # below: Application Engineer (Austin, TX) Integrate Google technology into client systems to satisfy the needs of the business. Google LLC; **Job code: 1615.31031** Exp Inc: Java, J2EE, & Web Services; API resource modeling, Design & Dev & Database schema design; Web App Design & Dev; Unit testing, integration testing & System testing; & Scalability & performance testing & performance tuning. Network Implementation Engineer (Austin, TX) Design, develop, & modify test plans for Google networking features, equipment, & systems. **Job Code: 1615.68514** Exp Inc: enterprise & service provider L2/IP/MPLS based network design, implementation or operation; debugging of

complex network & network device issues & fault isolations; data packet forwarding, routing protocols, data center networking tech; routing protocols; switching tech; MPLS, Traffic engineering, Layer 2 & layer 3 VPNs, MPLS; Python; & JNCIE-SP JNCIE-ENT & JNCIE-DC.

Positions report to the Google AUS office & may allow for partial telecommuting.

MULTIPLE POSITIONS

Visa Technology & Operations LLC, a Visa Inc. company, currently has an opening for Sr. SW Engineers (REF49567R) Architect, design, build, develop, test, and/or implement software systems and/or applications. Conduct business and technical analysis, code reviews and unit testing, and implement and product technical documentation of solutions for new development, system enhancements, and production support. Position reports to the Visa Austin, TX office and may allow for partial telecommuting. Director (multiple openings) (REF46944V) Lead and participate in designing, developing and testing Cloud Platform and Hybrid Cloud solutions (as a Service). Provide product design, optimization, deployment and operations for Visa products. Position reports to the Visa Austin, TX office and may allow for partial telecommuting. To apply, please reference job number above when mailing resume to: LJ, Visa Inc., MS: M1-12 SW, 900 Metro Center Blvd., Foster City, CA 94404

FREE ADS

Looking to hire a bartender? Have an apartment you need to rent? All you need to do is go online to austinchronicle.com/classifieds and post your ad for FREE. Make it stand out with pictures! Highlight it by making it a featured ad! You can even run it in print! Ads run online for 30 days, and are posted immediately. After all, immediate gratification takes too long!

MULTIPLE POSITIONS

Visa Technology & Operations LLC, a Visa Inc. company, currently has openings in Austin, Texas for: Cybersecurity Analyst (multiple openings) (REF50320F) Perform ethical penetration testing on various Visa mobile and Mac products and assets to simulate real-life security vulnerabilities and scenarios. Adaptation of mobile and Mac security assurance across Visa. Position reports to the Austin, Texas office and may allow for partial telecommuting. Sr. Systems Administrator (multiple openings) (REF51411I) Be responsible for maintenance and administration of Visa's SharePoint database environments through command line tools and PowerShell. Write and document PowerShell scripts for farm management and data automation. Position reports to the Visa Austin, TX office and may allow for partial telecommuting. Sr. SW Engineer (multiple openings) (REF51413Z) Architect, design, build, develop, test, and/or implement software applications. Conduct business and technical analysis, code reviews, and unit testing. Position reports to the Visa

Austin, TX office and may allow for partial telecommuting. Staff Data Engineer (multiple openings) (REF50950M) Collaborate with project team members (Product Managers, Architects, Analysts, Software Engineers, Project Managers, etc.) to ensure development and implementation of new data driven business solutions. Drive development effort End-to-End for on-time delivery of high quality solutions that conform to requirements, conform to the architectural vision, and comply with all applicable standards. Position reports to the Austin, Texas office and may allow for partial telecommuting. Application Programmer Analyst (multiple openings) (REF51381A) Architect, design, build, test, implement, and maintain scalable, distributed, and multi-threaded applications. Develop and deliver high quality, testable, and production-ready code. Position reports to the Austin, TX office and may allow for partial telecommuting. Sr. Technical Product Manager (multiple openings) (REF49721A) Develop products by identifying potential products, conducting market research, generating product requirements, determining specifications, creating production timetables, pricing, time-integrated plans for product introduction, and develop market strategies. Perform extensive research of category-specific requirements in the interest of customers and suppliers. Position reports to the Austin, Texas office and may allow for partial telecommuting. Sr. SW Engineers (REF50307U) Architect, design, build, develop, test, and/or implement software applications. Conduct business and technical analysis, code reviews, and unit testing. Position reports to the Austin, Texas office and may allow for partial telecommuting. Cybersecurity Engineer (multiple openings) (REF50221W) Perform maintenance and implementation of various enterprise identity management components such as IDM, Password Vault Management and Unix Administration. Perform system administration and deployment of solutions on Linux and Windows. Position reports to the Austin, Texas office and may allow for partial telecommuting. Systems Analyst (REF50222N) Support business-critical applications with huge Visa brand and financial impact. Ensure the stability of applications by performing proactive maintenance activities, engaging in automation activities, and performing root cause analysis and remediation. Position reports to the Austin, Texas office and may allow for partial telecommuting. Staff Data Engineer (multiple openings) (REF51453R) Collaborate with project team members to ensure development and implementation of new data driven business solutions. Drive development effort End-to-End for on-time delivery of high quality solutions that conform to requirements, conform to the architectural vision, and comply with all applicable standards. Position reports to the Visa Austin, TX office and may allow for partial telecommuting. Systems Analyst (multiple openings) (REF51482P) in Austin, TX to: Contribute to

project deliverables including, but not limited to requirements elaboration, functional design, application configuration and support plans. Perform unit and quality assurance testing including test case preparation, test execution and test results documentation, contribute to test strategies. Up to 5% domestic travel required. Position reports to the Visa Austin, TX office and may allow for partial telecommuting. Qualified applicants should apply by emailing resume to uscareers@visa.com. Must reference job code.

MULTIPLE POSITIONS

Visa U.S.A. Inc., a Visa Inc. company, currently has openings in Austin, Texas for: Sr. SW Engineer (multiple openings) (REF48653N) Develop next generation mobile payment applications. Write code following best development practices. Work as part of scrum teams executing product requirements working with UX, product management, and other teams. Position reports to the Austin, Texas office and may allow for partial telecommuting. Senior Product Manager (multiple openings) (REF49730X) Ensure suppliers & partners to manage compliance with contracts and service requirements, including adhering and holding them accountable to SLAs and business terms. Assess partner/supplier products, inquire on their services, and communicate product or service-related concerns. Position reports to the Visa Austin, TX office and may allow for partial telecommuting. Domestic travel required 10% of the time. Staff ML Scientist (multiple openings) (REF51455G) Work with a team to conduct world-class research on data analytics and contribute to the long-term research agenda in large-scale data analytics and machine learning, as well as deliver innovative technologies and insights to Visa's strategic products and business. Position reports to the Visa Austin, TX office and may allow for partial telecommuting. HR Analytics Analyst (multiple openings) (REF50959K) engage with Talent Acquisition leadership, Talent Management, Workforce Planning, Diversity & Inclusion to optimize the utilization of metrics and analytics data. Develop dashboards, benchmarking, and data-driven insights for enterprise-wide talent acquisition strategies and initiatives. Position reports to the Visa Austin, TX office and may allow for partial telecommuting. Qualified applicants should apply by emailing resume to uscareers@visa.com. Must reference job code.

PROGRAM MANAGERS

Oracle America, Inc. has openings for Program Managers positions in Austin, Texas. Job duties include: Manage the development and implementation process of a specific company product. May telecommute from home. Apply by e-mailing resume to craig.pennington@oracle.com, referencing 385.28277. Oracle supports workforce diversity.

THE ALABAMA-COUSHATTA TRIBAL EMPLOYMENT & TRAINING PROGRAM

Looking for Native American Indians, Alaskan Natives or Native Hawaiians needing assistance finding employment or vocational training

Must be a member of a US Federally recognized tribe with a supporting document from a US Federally recognized Tribe's Tribal Rolls and Records office and reside within our designated service area in Texas.

Workforce Innovation and Opportunity Act Section 166, 20 CFR 684.300(a) (1) An Indian, as determined by a policy of the INA program grantee; or (2) An Alaska Native; or (3) A Native Hawaiian.

Call: 1-877-717-6101
or apply online at www.acwia.org

casagarcias
Mexican Restaurant & Cantina

NOW HIRING!

LINE COOKS • DISHWASHERS • BUSBOYS
STARTING AT \$13-17/HR & 36-40 HOURS WEEKLY

CASHIERS NEEDED - \$15/HOUR

We offer Health Benefits, Weekly Pay, Food Discounts, Life Insurance, Paid Vacation.
Apply in person for immediate interview or call 512-569-0386. **Se Habla Español**

CASAGARCIAS.COM/JOBS

SENIOR AI ENGINEER - ZENIMAX MEDIA INC. - AUSTIN, TEXAS

Resp. for: collaborating w/ producers, designers, & artists on individual AI archetypes from conception to completion; authoring/maintaining core AI systems and features; identifying/implementing platform-specific optimizations to AI systems; and working on other game systems and features as required. Req'd: Substantial work on a shipped AAA game title; min 5 years' programming games; min 5 years writing portable/maintainable code; min 5 years w/ C++ & language & design; min 5 years using linear algebra & matrices; min 3 years w/ modern AI systems & architectures; min 3 years w/ character navigation, animation, & physics systems; min 3 years w/ NPC behaviors; min 1 year working on multiplayer games. Bach. Degree in Comp Sci or related (foreign degree acceptable). Must pass bkgd check & provide 2 positive references. To Apply: Submit resume to jobs@zenimax.com.

SENIOR PRINCIPALS

Slalom's Austin, TX office has multiple openings for Senior Principals (various types/levels): Directs activities of software systems development function, software apps. development function, & software QA function for software enhancements & new products inc. cloud-based or internet-related tools. Must be available to work on projects at various, unanticipated sites w/n commuting distance of Slalom office. **TO APPLY:** Go to www.jobposting-today.com, search for job ID 63926 & submit resume.

SENIOR SOFTWARE ENGINEER

sought by Aristocrat Technologies, Inc. in Austin, TX. Design & impl new features & services of cloud-based platform for games. Req: BS+5 yrs/MS+2 yrs. May telecommute in Austin, TX area. Apply by email to: Aristocrat Technologies, Inc. Attn: J.Hollis, jade.hollis@aristocrat.com (Ref Job code: TX0509)

SOFTWARE DEVELOPMENT ENGINEER II

Amazon.com Services LLC seeks candidates for the following (multiple positions available) in Austin, TX: Software Development **Software Development Engineer II (Job Code 2155584).** Design, develop, implement, test and document embedded or distributed software applications, tools, systems and services. Qualified applicants should apply at: <https://www.amazon.jobs/en/> referencing the job code: 2155584.

SOFTWARE DEVELOPMENT ENGINEER II

CSIdentity Corporation in Austin, TX is seeking to fill the position of Software Development Engineer II to work on higher risk and more complex components - drives tuning and optimizations within components. Send resumes to Amy Harmon, HR, via email at Amy.Harmon@experian.com. Must reference job code 20596.113.

SOFTWARE ENGINEER II

Wal-Mart is seeking a Software Engineer II in Austin, TX. Job duties incl but not limited to participating in small to medium-sized complex team proj's by reviewing & understanding proj req mts; translating req mts into tchncl solutions. Bachelor's or equiv in CS, IT, Eng or rel. fld + 1 yr of exp in IT or rel. fld; OR Master's or equiv in CS, IT, Eng, or rel. fld. Skills req'd incl but not limited to exp w/: creating highly scalable & optimized code using object-oriented prog'g languages & SOLID constructs; dvlpng & deploying REST API Microsvcs on Cloud; performing lrg scale data migration btwn relational & non-relational databases incl Big Query, MySQL, MSSQL & Elasticsearch; dsgn'g & implementing UI & visualizations using Big Query, Power BI, & React. Employer will accept any amount of grad coursework, grad research exp or prof'l exp w/req'd skills. For detailed job req mts & to apply, visit <http://careers.walmart.com>, & apply to the following Job ID # R-1192809. EOE, AAE.

SOFTWARE ENGINEERING SENIOR ADVISORS

(Austin, TX) Full life cycle project ownership from analysis to applic dvlpmnt to delivery of IT solutions. Dvlp solid, scalable systems aligned to established architecture guidelines, patterns. Virtual / work from home benefit available. Reqs MS in CompSci, Electrical Eng, or rtd & 2 yrs IT exp (or BS and 5 yrs exp). All qualifying exp must incl: applic dvlpmnt in Agile enviro & healthcare domain; Hadoop; Hive; Impala; HDFS; Jenkins; UDeploy; Git; TDD; d/bases incl Teradata, Oracle, DB2, &/or Amazon d/bases; SQL; shell scripting; SAS; HiveQL. Resumes to Evernorth Enterprise Services, Inc. at: tapan.aggarwal@evernorth.com

SR. SOFTWARE ENGINEER

H-E-B seeks Sr. Software Engineer in Austin, TX to provide data solutions for ecommerce, supply chain, store operations, finance, and marketing reporting and analytics platforms. E-Mail resumes to: Marisa Alcorta, at alcorta.marisa@hcb.com

PLEASE CHECK YOUR AD

for accuracy the first time it runs. The Austin Chronicle is not responsible for copy errors after the first week of publication. The Austin Chronicle's liability for errors is limited to the cost of the space occupied by the error, with a maximum liability of republication. Corrections must be submitted by Tuesday, 3pm.

STRUCTURE DESIGN MANAGER

Ferrovial Construction US Corp., Austin, TX. Coordinate engineering design activities. Req. Bach's deg or foreign equiv in Civil Engg, Structural Engg or rel + 3 yrs post-bach's, prograss, rel work exp. Must have or be eligible to obtain a Texas state Professional Engineer PE license. Up to 10% travel req. Please email resume to recruitment@ferrovial.us referencing job code (reference: FCUCSDM2022JT-JB)

SW ENGINEER IV

Visa U.S.A. Inc., a Visa Inc. company, currently has an openings for: SW Engineer IV (multiple openings) (REF46966J) Develop next generation mobile payment applications; write solid code following best development practices. Work as a part of scrum team executing the products requirements working with UX, product management and other teams in an agile manner. Position reports to the Visa Austin, Texas office and may allow for partial telecommuting. To apply, please reference job number above when mailing resume to: LJ, Visa Inc., MS: M1-12 SW, 900 Metro Center Blvd., Foster City, CA 94404

TECH ARCHITECTURE DELIVERY MANAGER

(Accenture LLP; Austin, TX): Design, implement, and/or support world-class information technology architecture for Accenture or our clients, spanning simple IT projects to large-scale, enterprise-level change programs. Must have willingness and ability to travel domestically approximately 80% of the time to meet client needs. Multiple Positions Available. For complete job description, list of requirements, and to apply, go to: www.accenture.com/us-en/careers (Job# R00117666). Equal Opportunity Employer - Minorities/Women/Vets/Disabled.

TECHNOLOGY

Hewlett Packard Enterprise advances the way people live and work. HPE is accepting resumes for the position of IT Developer/Engineer in Austin, TX (Ref. #5687797). Participate as a member of and lead cross-functional development teams to analyze the cross-functional and complex business requirements using tools such as JIRA. Collaborate with business teams to transform the business requirements into an enterprise-grade technical solution. Telecommuting is permitted. Up to 10% travel required to various and unanticipated HPE and client sites throughout the U.S. E-Mail resume to Hewlett Packard Enterprise

Company, global.employee.mobility@hpe.com. Resume must include Ref. #, full name, email address & mailing address. No phone calls. Must be legally authorized to work in U.S. without sponsorship. EOE.

TECHNOLOGY

Oracle America, Inc. has openings for Cloud Solution Engineer positions in Austin, TX. Job duties include: Partners with customers, sales, engineering, and product teams to design, demonstrate and deploy Oracle Cloud architectures that address customer business problems. May telecommute from home. Travel to various unanticipated sites throughout the United States and internationally required. Apply by e-mailing resume to jeff.ramby@oracle.com, referencing 385.22826. Oracle supports workforce diversity.

TECHNOLOGY

Oracle America, Inc. has openings for Programmer Analyst positions in Austin, TX. Job duties include: Analyze user requirements to develop, implement, and/or support Oracle's global infrastructure. May telecommute from home. Apply by e-mailing resume to vamsi.morusupalli@oracle.com, referencing 385.28042. Oracle supports workforce diversity.

TECHNOLOGY

Oracle America, Inc. has openings for System Administrator positions in Austin, TX. Job duties include: Define, design, and implement network communications and solutions within a fast-paced, leading edge database/applications company. May telecommute from home. Travel to various unanticipated sites throughout the United States Required. Apply by e-mailing resume to steve.messer@oracle.com, referencing 385.28587. Oracle supports workforce diversity.

EMPLOYMENT

Hire employees who are as smart as you are! Advertise your positions in The Austin Chronicle's Help Wanted section. Call 512-454-5765 for more info.

GENERAL

LIVE IN CAREGIVER

I am in need of a person to help with daily needs. Call at 737-701-3288 for more information.

PROFESSIONAL

BUSINESS

Hewlett Packard Enterprise advances the way people live and work. HPE is accepting resumes for the position of Business Operations Manager in Austin, TX (Ref. #6031717). Responsible to lead and coordinate globally GTS (Global Trade Systems) projects including upstream and downstream systems such as SAP S4, Legacy, Intrastat, Importsys. Accountable to maintain key tables in Customs Assets such as Smartforms, business partner set up and filter tables. Telecommuting is permitted. Up to 10% travel required to various and unanticipated HPE and client sites throughout the U.S. E-Mail resume to Hewlett Packard Enterprise Company, global.employee.mobility@hpe.com. Resume must include Ref. #, full name, email address & mailing address. No phone calls. Must be legally authorized to work in U.S. without sponsorship. EOE.

RISK ANALYST (MULT. POS.)

ByteDance Inc., Risk Analyst (Mult.Pos.), Austin, TX. Support the design & optimization of ad policies, moderation processes, scalable systems & tools to identify risks & drive efficiencies within integrity mechanisms. Identify, investigate, & communicate emerging risks in ads ecosystem. Apply online @ <https://jobs.bytedance.com/en/> & type Job ID Q8844 in search bar. Contact lpresumes@bytedance.com if you have difficulty applying.

WEBSITE Looking for something more? Check out austin-chronicle.com/classifieds for even more great ads online.

E 6th St, Ste 112, Austin, Travis County, Texas. Managers: Alexander Buckle & Olivia Adams.

Application has been made with the Texas Alcoholic Beverage Commission for a Wine and Malt Beverage Retail Dealer's On-Premise Permit by Foxtrot Retail Texas, Inc. dba Foxtrot located at 4818 Burnet Road, Austin, Travis County, Texas 78756. Michael Lavitola – President/Secretary/Director; William Bloom – VP/ Director.

Application has been made with the Texas Alcoholic Beverage Commission for a Mixed Beverage Permit by Blade and Timber Texas LLC d/b/a Blade and Timber, to be located at 3005 S. Lamar Blvd., Suite 110-A, Austin, Travis County, Texas 78704. The Manager of Applicant is Blade and Timber LLC. The Manager of Blade and Timber LLC is Matthew Baysinger.

Application has been made with the Texas Alcoholic Beverage Commission for a Mixed Beverage Permit by Stout's Pizza Co., LLC dba Stout's Pizza Co., 1109 E. 5th Street, Suite 105, Austin, Travis County, Texas. Jason Stout, Pres/Member.

Application has been made with the Texas Alcoholic Beverage Commission for a Wine and Beer Retailer's Off Premises (BQ) permit by 3611 Pace Bend LLC dba WOODY'S Country Market #4, to be located at 3611 Pace Bend Rd S, SPICEWOOD, TRAVIS COUNTY, TEXAS 78669. Officers of said corporation are ABID MOMIN - Member Managed IRFAN DHUKA -

Member Managed

Application has been made with the Texas Alcoholic Beverage Commission for a Wine and Malt Beverage Retail Dealer's On-Premise Permit by Foxtrot Retail Texas, Inc. dba Foxtrot located at 4818 Burnet Road, Austin, Travis County, Texas 78756. Michael Lavitola – President/Secretary/Director; William Bloom – VP/ Director.

CITATION BY PUBLICATION
THE STATE OF TEXAS
CAUSE NO: D-1-GN-21-007086
To: **UNKNOWN HEIRS AT LAW OF H C JOHNSON**
Defendant(s), in the hereinafter styled and numbered cause: YOU (AND EACH OF YOU) HAVE BEEN SUED. You may employ an attorney. If you or your attorney do not file a written answer with the clerk who issued this citation by 10:00 A. M. on the Monday next following the expiration of 42 days from the date of issuance hereof, that is to say at or before 10 o'clock A.M. of Monday the October 3, 2022, and answer the PLAINTIFF'S ORIGINAL PETITION of Plaintiff(s), filed in the 419th District Court of Travis County, Texas, on December 07, 2021, a default judgment may be taken against you. In addition to filing a written answer with the clerk, you may be required to make initial disclosures to the other parties of this suit. These disclosures generally must be made no later than 30 days after you file your answer with the clerk. Find out more at TexasLawHelp.org.

Said suit being number D-1-GN-21-007086, in which **AMERICAN ADVISORS GROUP Plaintiff(s)**, vs. **UNKNOWN HEIRS AT LAW OF H C JOHNSON Defendant(s)**, and the nature of which said suit is as follows: **Plaintiff American Advisors Group, its successors in interest or assigns, by and through its attorney of record Joseph M. Vacek of Robertson, Anschutz, Schneid, Crane & Partners, PLLC, 5601 Executive Dr., Suite 400, Irving, Texas 75038, brought suit against The Unknown Heirs of H. C. Johnson, deceased, and any other person claiming any subordinate right. title and/or interest in 7506 Long Point Dr., Austin, Texas 78731 ("Property"), and legally described as: LOT 1, BLOCK E, VISTA WEST-1, TRAVIS COUNTY, TEXAS, ACCORDING TO**

LEGAL NOTICES

CALL TODAY 512/454-5767

1st PUBLIC NOTICE OF ABANDONED VEHICLES - Public notice is hereby given that MJVMJ Inc., Rocha's Towing Service, Special Automotive, (TDLR VSF license number #0534246VSF) to the owners of the following vehicles that charges are due, and a storage lien applies. 2007 BMW 328i, No Plates, VIN: WBAVC53557FZ75440; If left unclaimed 51 days after the date of this notice, they will be declared abandoned and constitutes a waiver of all liens, title, and interest, and consent for disposal at public sale. The vehicle can be claimed with proof of ownership and payment of accrued charges at 5700 Burlleson Rd, Austin, TX 78744, 512-280-2642.

Application has been

made with The Texas Alcoholic Beverage Commission for A Package Store Permit by 6328 S Hwy 183 LLC dba Starbeam Liquor #9 to be located at 6328 S Highway 183, Austin, Travis County Texas. Manager of said LLC is Najib F. Wehbe – Manager

Application has been

made with the Texas Alcoholic Beverage Commission for a Mixed Beverage Permit with Food and Beverage Certificate, by Dandelion Cafe, LLC. dba Blue Dahlia Bistro to be located at 3663 Bee Caves Rd Ste 4A Westlake Hills, Travis County, TX, 78746. Officers are Amy Ramirez- managing

member, Samuel Ramirez- managing member, Fredrick Nelson- managing member. Application has been made with the Texas Alcoholic Beverage Commission for a Brewer's License (BW) by Wanderlust Wine Company LLC dba Wanderlust Wine Co., to be located at 702

Shady Lane Austin, Travis County, Texas 78702. Managing Member is Sammy Angel Lam. Application has been made with the Texas Alcoholic Beverage Commission for a Brewer's License (BW) by Wanderlust Wine Company LLC dba Wanderlust Wine Company, to be located

at 610 N Interstate 35 Austin, Travis County, Texas 78701. Managing Member is Sammy Angel Lam. Application has been made with the Texas Alcoholic Beverage Commission for a Mixed Beverage Permit and Mixed Beverage Late Hours by ATXE6 LLC dba X Crem located at 1614

THE MAP OR PLAT THEREOF RECORDED IN VOLUME 50, PAGE 45, MAP AND/OR PLAT RECORDS OF TRAVIS COUNTY, TEXAS.

TAX ACCOUNT #: 0143061006; **ALT APN** 142864 ALL OF WHICH MORE FULLY APPEARS FROM: **PLAIN-TIFF'S ORIGINAL PETITION ON FILE IN THIS OFFICE, AN D WHICH REFERENCE IS HERE MADE FOR ALL INTENTS AND PURPOSES.**

Issued and given under my hand and the seal of said court at Austin, Texas, August 17, 2022.

VELVA L. PRICE
Travis County District Clerk
1000 Guadalupe, P.O. Box
679003

Austin, Texas 78767

REQUESTED BY:

VACEK, JOSEPH MICHAEL
5601 EXECUTIVE DR STE 400
IRVING, TX 75038-2508

Prepared by: Adrian Rodriguez

CITATION BY PUBLICATION THE STATE OF TEXAS TO UNKNOWN HEIRS OF ALBERT G. AGUILERA, DECEASED IN PROBATE COURT NUMBER 1, TRAVIS COUNTY, TEXAS.

CAUSE NO. C-1-PB-22-001942 Sandra Ann Aguilera filed an Application to Determine Heirship in the above-numbered and-entitled estate on **August 18, 2022**, requesting that the Court determine who are the heirs and only heirs of **Albert G. Aguilera**, Deceased, and their respective shares and interests in such estate.

All unknown heirs and any other persons interested in this estate are cited to appear before this Court by filing a written contest or answer to this application if they want to do so. The Court may act on this application at any time at the Probate Court #1, Probate Courthouse, 200 West 8th Street, Austin, Texas 78701, on or after 10:00 a.m. on the first Monday after the expiration of ten days from the publication date of this citation. Therefore, to ensure consideration, any contest, answer, or other response must be filed with the Travis County Clerk in cause number **C-1-PB-22-001942**, styled **IN THE ESTATE OF ALBERT G. AGUILERA, DECEDENT** on or before the above-noted date and time.

If this citation is not served within 90 days after it is issued, it must be returned unserved. Given under my hand and seal on **this the 18th day of August, 2022**,

REBECCA GUERRERO, County Clerk

Travis County, Texas
200 West 8th Street, Ste. 140
Austin, TX 78701
P.O. Box 149325
Austin, Texas 78714-9325

By: **B. HICKS**

CITATION BY PUBLICATION THE STATE OF TEXAS TO UNKNOWN HEIRS OF CATHERINE LINDSAY MESHEW, DECEASED IN PROBATE COURT NUMBER 1, TRAVIS COUNTY, TEXAS .

CAUSE NO. C-1-PB-22-001019 TERRI K. MESHEW filed an APPLICATION TO DETERMINE HEIRSHIP AND FOR LETTERS OF INDEPENDENT ADMINISTRATION in the above-numbered and

-entitled estate on **April 22, 2022**, requesting that the Court determine who are the heirs and only heirs of **Catherine Lindsay Meshew**, Deceased, and their respective shares and interests in such estate.

All unknown heirs and any other persons interested in this estate are cited to appear before this Court by filing a written contest or answer to this application if they want to do so. The Court may act on this application at any time at the Probate Court #1, Probate Courthouse, 200 West 8th Street, Austin, Texas 78701, on or after 10:00 a.m. on the first Monday after the expiration of ten days from the publication date of this citation. Therefore, to ensure consideration, any contest, answer, or other response must be filed with the Travis County Clerk in cause number **C-1-PB-22-001019**, styled **IN THE ESTATE OF Catherine Lindsay Meshew, DECEASED** on or before the above-noted date and time. If this citation is not served within 90 days after it is issued, it must be returned unserved. Given under my hand and seal on **this the 28th day of April, 2022**,

REBECCA GUERRERO, County Clerk

Travis County, Texas
200 West 8th Street, Ste. 140
Austin, TX 78701
P.O. Box 149325
Austin, Texas 78714-9325

By: **G DALESSIO**

CITATION BY PUBLICATION THE STATE OF TEXAS TO UNKNOWN HEIRS OF CHRISTINA MICHELLE LIMON ONTIVEROS, DECEASED IN PROBATE COURT NUMBER 1, TRAVIS COUNTY, TEXAS.

CAUSE NO. C-1-PB-22-001943 Alicia Rachel Limon Gil filed an Application to Determine Heirship and for Appointment of Independent Administrator and Issuance of Letters of Independent Administration or in the Alternative for Appointment of Dependent Administrator and Issuance of Letters of Dependent Administration in the above-numbered and -entitled estate on **August 18, 2022**,

requesting that the Court determine who are the heirs and only heirs of **Christina Michelle Limon Ontiveros**, Deceased, and their respective shares and interests in such estate.

All unknown heirs and any other persons interested in this estate are cited to appear before this Court by filing a written contest or answer to this application if they want to do so. The Court may act on this application at any time at the Probate Court #1, Probate Courthouse, 200 West 8th Street, Austin, Texas 78701, on or after 10:00 a.m. on the first Monday after the expiration of ten days from the publication date of this citation. Therefore, to ensure consideration, any contest, answer, or other response must be filed with the Travis County Clerk in cause number **C-1-PB-22-001943**, styled **IN THE ESTATE OF Christina Michelle Limon Ontiveros, DECEASED** on or before the above-noted date and time.

If this citation is not served within 90 days after it is issued, it must be returned unserved. Given under my hand and seal on **this the 23rd day of August, 2022**,

If this citation is not served within 90 days after it is issued, it must be returned unserved. Given under my hand and seal on **this the 18th day of August, 2022**,

REBECCA GUERRERO, County Clerk
Travis County, Texas
200 West 8th Street, Ste. 140
Austin, TX 78701
P.O. Box 149325
Austin, Texas 78714-9325

By: **B. HICKS**

CITATION BY PUBLICATION THE STATE OF TEXAS TO UNKNOWN HEIRS OF NOE ROLANDO GONZALES, DECEASED IN PROBATE COURT NUMBER 1, TRAVIS COUNTY, TEXAS.

CAUSE NO. C-1-PB-22-001970 ESTHER MORENO GONZALES filed an APPLICATION FOR DETERMINATION OF HEIRSHIP AND LETTERS OF INDEPENDENT ADMINISTRATION in the above-numbered and -entitled estate on **August 22, 2022**, requesting that the Court determine who are the heirs and only heirs of **Noe Rolando Gonzales**, Deceased, and their respective shares and interests in such estate.

All unknown heirs and any other persons interested in this estate are cited to appear before this Court by filing a written contest or answer to this application if they want to do so. The Court may act on this application at any time at the Probate Court #1, Probate Courthouse, 200 West 8th Street, Austin, Texas 78701, on or after 10:00 a.m. on the first Monday after the expiration of ten days from the publication date of this citation. Therefore, to ensure consideration, any contest, answer, or other response must be filed with the Travis County Clerk in cause number **C-1-PB-22-001970**, styled **IN THE ESTATE OF Noe Rolando Gonzales, DECEASED** on or before the above-noted date and time.

If this citation is not served within 90 days after it is issued, it must be returned unserved. Given under my hand and seal on **this the 23rd day of August, 2022**,

REBECCA GUERRERO, County Clerk
Travis County, Texas
200 West 8th Street, Ste. 140
Austin, TX 78701
P.O. Box 149325
Austin, Texas 78714-9325

By: **J. ACOSTA**

CITATION BY PUBLICATION THE STATE OF TEXAS TO UNKNOWN HEIRS OF RICHARD MENDOZA, DECEASED IN PROBATE COURT NUMBER 1, TRAVIS COUNTY, TEXAS.

CAUSE NO. C-1-PB-20-002007 ELSA MENDOZA filed a FIRST AMENDED APPLICATION FOR DETERMINATION OF HEIRSHIP AND ISSUANCE OF LETTERS OF INDEPENDENT ADMINISTRATION in the above-numbered and -entitled estate on **May 26, 2022**, requesting that the Court determine who are the heirs and only heirs of **RICHARD MENDOZA**, Deceased, and their respective shares and interests in such estate.

All unknown heirs and any other persons interested in this estate are cited to appear before this Court by filing a written contest or answer to this application if they want to do so. The Court may act on this application at any time at the Probate Court #1, Probate Courthouse, 200 West 8th Street, Austin, Texas 78701, on or after 10:00 a.m. on the first Monday after the expiration of ten days from the publication date of this citation. Therefore, to ensure consideration, any contest, answer, or other response must be filed with the Travis County Clerk in cause number **C-1-PB-22-001887**, styled **IN THE ESTATE OF Rufus Castillo, Sr., DECEASED** on or before the above-noted date and time.

If this citation is not served within 90 days after it is issued, it must be returned unserved. Given under my hand and seal on **this the 11th day of August, 2022**,

other persons interested in this estate are cited to appear before this Court by filing a written contest or answer to this application if they want to do so. The Court may act on this application at any time at the Probate Court #1, Probate Courthouse, 200 West 8th Street, Austin, Texas 78701, on or after 10:00 a.m. on the first Monday after the expiration of ten days from the publication date of this citation. Therefore, to ensure consideration, any contest, answer, or other response must be filed with the Travis County Clerk in cause number **C-1-PB-20-002007**, styled **RICHARD MENDOZA** on or before the above-noted date and time.

If this citation is not served within 90 days after it is issued, it must be returned unserved. Given under my hand and seal on **this the 18th day of August, 2022**,

REBECCA GUERRERO, County Clerk
Travis County, Texas
200 West 8th Street, Ste. 140
Austin, TX 78701
P.O. Box 149325
Austin, Texas 78714-9325

By: **G. DALESSIO**

CITATION BY PUBLICATION THE STATE OF TEXAS TO UNKNOWN HEIRS OF RUFUS CASTILLO, SR., DECEASED IN PROBATE COURT NUMBER 1, TRAVIS COUNTY, TEXAS.

CAUSE NO. C-1-PB-22-001887 RUFUS CASTILLO, JR. AND ANITA LONGORIA filed an APPLICATION FOR DETERMINATION OF HEIRSHIP AND APPOINTMENT OF INDEPENDENT CO-ADMINISTRATORS in the above-numbered and -entitled estate on **August 10, 2022**, requesting that the Court determine who are the heirs and only heirs of **Rufus Castillo, Sr.**, Deceased, and their respective shares and interests in such estate.

All unknown heirs and any other persons interested in this estate are cited to appear before this Court by filing a written contest or answer to this application if they want to do so. The Court may act on this application at any time at the Probate Court #1, Probate Courthouse, 200 West 8th Street, Austin, Texas 78701, on or after 10:00 a.m. on the first Monday after the expiration of ten days from the publication date of this citation. Therefore, to ensure consideration, any contest, answer, or other response must be filed with the Travis County Clerk in cause number **C-1-PB-22-001887**, styled **IN THE ESTATE OF Rufus Castillo, Sr., DECEASED** on or before the above-noted date and time.

If this citation is not served within 90 days after it is issued, it must be returned unserved. Given under my hand and seal on **this the 11th day of August, 2022**,

REBECCA GUERRERO, County Clerk
Travis County, Texas
200 West 8th Street, Ste. 140
Austin, TX 78701
P.O. Box 149325
Austin, Texas 78714-9325

By: **G DALESSIO**

CITATION BY PUBLICATION THE STATE OF TEXAS TO UNKNOWN HEIRS OF**RUSSELL ANDERS SEASHORE, DECEASED IN PROBATE COURT NUMBER 1, TRAVIS COUNTY, TEXAS.**

CAUSE NO. C-1-PB-22-001952 JAYLYNN SEASHORE filed an APPLICATION FOR DETERMINATION OF HEIRSHIP AND FOR LETTERS OF INDEPENDENT ADMINISTRATION in the above-numbered and -entitled estate on **August 18, 2022**, requesting that the Court determine who are the heirs and only heirs of **Russell Anders Seashore**, Deceased, and their respective shares and interests in such estate.

All unknown heirs and any other persons interested in this estate are cited to appear before this Court by filing a written contest or answer to this application if they want to do so. The Court may act on this application at any time at the Probate Court #1, Probate Courthouse, 200 West 8th Street, Austin, Texas 78701, on or after 10:00 a.m. on the first Monday after the expiration of ten days from the publication date of this citation. Therefore, to ensure consideration, any contest, answer, or other response must be filed with the Travis County Clerk in cause number **C-1-PB-22-001952**, styled **IN THE ESTATE OF Russell Anders Seashore, DECEASED** on or before the above-noted date and time.

If this citation is not served within 90 days after it is issued, it must be returned unserved. Given under my hand and seal on **this the 18th day of August, 2022**,

REBECCA GUERRERO, County Clerk
Travis County, Texas
200 West 8th Street, Ste. 140
Austin, TX 78701
P.O. Box 149325
Austin, Texas 78714-9325

By: **B. HICKS**

CITATION BY PUBLICATION THE STATE OF TEXAS TO: The Estate of Jose Cruz, Deceased, and any Unknown Party who may claim as Heir, Devisee, Grantee Assignee, Lienor, Creditor, Trustee, or other claimant by, through, or against Jose Cruz, Deceased.

Defendant, in the hereinafter styled and numbered cause: **You have been sued.** If you or your attorney do not file a written answer with the clerk who issued this citation by 10:00 am. on the Monday next following the expiration of forty-two (42) days from the date of issuance of this citation, the same being Monday 10/03/2022. a default judgment may be taken against you. **In addition to filing a written answer with the clerk you may be required to make initial disclosures to the other parties of this suit. These disclosures generally must be made no later than 30 days after you file your answer with the clerk. Find out more at TexasLawhelp.org.** **CAUSE NUMBER: C-1-CV-22-001588**

Filed in **County Court at Law #1 Heman Marion Sweatt** Travis County Courthouse, 1000 Guadalupe, Austin, Texas. on 05/10/2022.

STYLED: Phase Three Austin's Colony Homeowners Association, Inc., Plaintiff VS. Jose Cruz, David Cruz,

Defendant NATURE OF SUIT: Contract - Other

Given under my hand and seal of Rebecca Guerrero. Counts Clerk on **this the 19th day of August, 2022.**

Rebecca Guerrero
County Clerk. Travis County, Texas

P.O. BOX 149325. Austin. Texas 78714-9325

By Deputy: ADESHAY
Plaintiff Attorney:
GREG GARZA
4301 WESTBANK DRIVE,
SUITE A-150
AUSTIN, TX 78746

CITATION BY PUBLICATION THE STATE OF TEXAS TO UNKNOWN HEIRS OF ALEXANDER RANDALL KING, DECEASED IN PROBATE COURT NUMBER 1, TRAVIS COUNTY, TEXAS.

CAUSE NO. C-1-PB-22-001959 Margaret Melissa King filed an Application for Appointment of Administrator, Determination of Heirship, and for Issuance of Letters of Administration in the above numbered and -entitled estate on **August 19, 2022**, requesting that the Court determine who are the heirs and only heirs of **Alexander Randall King**, Deceased, and their respective shares and interests in such estate.

All unknown heirs and any other persons interested in this estate are cited to appear before this Court by filing a written contest or answer to this application if they want to do so. The Court may act on this application at any time at the Probate Court #1, Probate Courthouse, 200 West 8th Street, Austin, Texas 78701, on or after 10:00 a.m. on the first Monday after the expiration of ten days from the publication date of this citation. Therefore, to ensure consideration, any contest, answer, or other response must be filed with the Travis County Clerk in cause number **C-1-PB-22-001959**, styled **IN THE ESTATE OF Alexander Randall King, DECEASED** on or before the above-noted date and time.

If this citation is not served within 90 days after it is issued, it must be returned unserved. Given under my hand and seal on **this the 22nd day of August, 2022**,

REBECCA GUERRERO, County Clerk
Travis County, Texas
200 West 8th Street, Ste. 140
Austin, TX 78701
P.O. Box 149325
Austin, Texas 78714-9325

By: **B. HICKS**

D-1-GN-20-005329 CONSTABLE'S NOTICE OF SALE

REAL PROPERTY DELINQUENT TAXES BY VIRTUE OF a certain Order Of Sale issued by the clerk of the 345th District Court of Travis County, on the 25th day of July, 2022 in a certain cause numbered D-1-GN-20-005329, wherein Ovation Services, LLC as Plaintiff and Travis County, Austin Travis Independent School District, Travis County Healthcare District d/b/a Central Health, City of Austin and Austin Community College as Intervenor and Santos Bocanegra, Jr., is/ are defendant(s), in favor of said

plaintiffs and intervenors, for the sum of **\$25,850.31** Dollars, together with all costs of suit, that being the amount of judgment recovered by the said plaintiffs, in the 345th District Court of Travis County, Texas, on August 30, 2021.

I, on the 29th day of July, 2022, at 2 o'clock P.M., have levied upon, and will, on the 6th day of September, 2022 at 10 o'clock, A.M., at 1000 Guadalupe Street in the City of Austin, within legal hours, proceed to sell for cash to the highest bidder, all the rights, title and interest of defendants in and to the following described property, levied upon as the property of defendants, to-wit:

Parcel No: 03-0618-0509-0000: Lot Five (5) in Block (3), Chernovsky Subdivision No. 15, an Addition in the City of Austin, Travis County, Texas according to map or plat thereof recorded in Volume 5, Page 92, Plat Records of Travis County, Texas also known as 909 Vargas, Austin, Texas

THE ABOVE SALE to be made by me to satisfy the above-described judgment for **\$25,850.31** Dollars in favor of plaintiffs, together with the costs of said suit, and the proceeds applied to the satisfaction thereof. Witness my hand this 29th day of July, 2022.

CARLOS B. LOPEZ, CONSTABLE PRECINCT 5 TRAVIS COUNTY, TEXAS BY Julien Smith DEPUTY ON THE PROPERTY SOLD, THERE ARE NO WARRANTIES, EXPRESS OR IMPLIED, INCLUDING, BUT NOT LIMITED TO, THE IMPLIED WARRANTIES OF MERCHANTABILITY AND FITNESS FOR A PARTICULAR PURPOSE. YOU BUY THE PROPERTY "AS IS". BIDDERS ARE FURTHER ADVISED THAT PURCHASE OF THE PROPERTY AT THIS EXECUTION SALE MAY NOT EXTINGUISH ANY LIENS OR SECURITY INTERESTS ON THE PROPERTY. YOU ARE SIMPLY PURCHASING WHATEVER INTEREST THE DEBTOR HAS IN THE PROPERTY. IF YOU HAVE ANY QUESTIONS, YOU NEED TO CONSULT COUNSEL OF YOUR CHOICE.

NOTICE IS HEREBY GIVEN IN ACCORDANCE WITH THE TERMS AND PROVISIONS OF THE TEXAS ALCOHOLIC BEVERAGE CODE THAT, RANCHO CASA AMIGOS LLC D/B/A RANCHO CASA AMIGOS LLC LOCATED AT 20117 LOCKWOOD ROAD, MANOR (OUTSIDE), TRAVIS COUNTY, TX 78653 HAS FILED APPLICATION FOR A WINE AND MALT BEVERAGE RETAILER'S PERMIT. PAUL R. HERCHMAN,

JR., MANAGER/MEMBER DONNA L. HERCHMAN, MEMBER NANCY C. LUDKOWSKI, MEMBER

Notice is hereby given in accordance with the terms and provisions of the Texas Alcoholic Beverage Code that VRD LLC dba Verdad True Modern Mexican has filed application for Food and Beverage Certificate and Mixed Beverage Permit. Said business to be conducted at 2701 Perseverance Dr, Austin (Travis County), TX 78731 VRD LLC dba Verdad True Modern Mexican Christopher Perry - Manager.

NOTICE OF ABANDONED VEHICLES

2nd NOTICE: 1971 CADILLAC DeVille(CA) 260CJA . Local charges assessed as of 08/19/2022 \$804.12. A&A Wrecker and Recovery 2905 West Howard Lane (512) 670-7578 VSF license 065330V5F www.tdlr.texas.gov

NOTICE OF ABANDONED VEHICLES

FIRST NOTICE PURSUANT OF TEXAS ABANDONED MOTOR VEHICLE ACT, THE FOLLOWING WILL BE SOLD AT A PUBLIC AUCTION UNLESS CLAIMED. GARAGE KEEPER: TRI-CITY TOWING, First Notice: 2007 PETERBILT 387 IA-DD3737 VIN# 1XP7DB9X77D692239 2000 TOYOTA COROLLA NO PLATES VIN# 2T1BR18E4YC298557

NOTICE OF ABANDONED VEHICLES.

PURSUANT OF TEXAS ABANDONED MOTOR VEHICLE ACT, www.tdlr.texas.gov THE FOLLOWING WILL BE SOLD AT PUBLIC SALE UNLESS CHARGES ARE SATISFIED WITHIN 30 DAYS. If the vehicle is not claimed 30 days after the date this notice is sent gives this storage facility the right to dispose of the vehicle. Additionally, failure to claim the vehicle is a waiver of all right, title, or interest in the vehicle and personal property and a consent to sell the vehicle at a public sale. GARAGE KEEPER: SOUTHSIDE WRECKER, 0655976V5F, 1111 OLD BASTROP HWY, AUSTIN, TX, 78742. (512)441-7094. 1ST NOTICE 2022 OTHER MOTORCYCLE L2BB2BCH6N123095 \$411.08

CONTINUED ON P.67

TRAVIS COUNTY, TEXAS

A resolution of the Commissioners Court of Travis County, Texas authorizing an amendment to the boundaries of the Turner's Crossing Public Improvement District, pursuant to Chapter 372 of the Texas Local Government Code; providing for related matters; and providing an effective date

RECITALS

A. On August 24, 2018, the Petitioners' (as defined herein) predecessor in interest (the "Original Petitioner"), submitted and filed a petition (the "August 2018 Petition") with the County Clerk (the "County Clerk") of Travis County, Texas (the "County") pursuant to the Public Improvement District Assessment Act, Chapter 372, Texas Local Government Code, as amended (the "PID Act") requesting the creation of a public improvement district located in the County and in the extraterritorial jurisdiction of the City of Austin, Texas (the "City") to be known as Turner's Crossing Public Improvement District (the "District") over approximately 469 acres of land.

B. On October 16, 2018, the Commissioners Court of the County (the "Commissioners Court") approved: (1) setting a public hearing on November 6, 2018 to receive comments on the August 2018 Petition, (2) publishing notice of the public hearing, and (3) mailing notice of the hearing to affected parties;

C. On October 19, 2018, the Original Petitioner submitted correspondence (the "October 2018 Correspondence," the October 2018 Correspondence and the August 2018 Petition, together, the "2018 Petition") to revise the boundaries of the proposed public improvement district so that the district would comprise approximately 445 acres rather than approximately 469 acres.

D. The Commissioners Court, pursuant to and in accordance with the terms, provisions, and requirements of the PID Act, authorized the creation of the District pursuant to a resolution (the "Authorization Resolution") adopted by the Commissioners Court on November 13, 2018, which Authorization Resolution was published in a newspaper of general circulation in the County and the extraterritorial jurisdiction of the City on December 7, 2018.

E. No objection was made by the City to the establishment of the District within 30 days of the County's action approving the Authorization Resolution.

F. The boundaries of the District, as provided to the County by the Original Petitioner and as depicted in the Authorization Resolution, contained a total of approximately 445.39 acres, and excluded an approximately 13.863 acre multifamily tract located adjacent to the District and north of S.H. 45, (the "North Multifamily Tract") and an approximately 9.293 acre multifamily tract located adjacent to the District and south of S.H. 45 (the "South Multifamily Tract"), and together with the North Multifamily Tract, the "Multifamily Tracts").

G. In June 2018 the then-owner of the land within the Turner's Crossing development (the "Development") submitted a preliminary plan for the Development to the Commissioners Court.

H. The Multifamily Tracts are located within the boundaries of the Development but not within the boundaries of the District.

I. During the course of the preliminary planning process for the Development, and in response to comments provided by County staff to the initial preliminary plan, the Petitioners redrew the boundaries of the North Multifamily Tract in order to include a second access road (the "East Access Road"), in accordance with Section D106 of the International Fire Code, adopted by the Commissioners Court.

J. During the process of adding the East Access Road, the then-owner of the land in the District made the following adjustments to the residential lots bordering the North Multifamily Tract: (i) the easternmost fifty-foot lot was replaced by the East Access Road; and (ii) the access road located on the western portion of the North Multifamily Tract (the "West Access Road") was shifted further west, allowing for the inclusion of an offsetting fifty-foot lot to be designated as Lot 95 (as defined herein) in the preliminary plan.

K. During the course of the preliminary planning process for the Development, the Petitioners redrew the boundaries of the South Multifamily Tract in order to remove a portion of the South Multifamily Tract located within a Critical Environmental Feature Buffer that the Petitioners determined would be more useful as open space or parkland.

L. On June 18, 2019, the Commissioners Court approved the preliminary plan for the Development, which incorporates the above-described changes to the Multifamily Tracts and depicts the North Multifamily Tract as containing approximately 14.122 acres and the South Multifamily Tract as containing approximately 7.691 acres.

M. On April 30, 2021, the Petitioners recorded Document No. 202100102 in the Official Public Records of Travis County, Texas (the "Phase 1 Plat"), for Turner's Crossing North Phase 1, which includes the first phase of development of the District ("Improvement Area #1"), and which officially depicts the North Multifamily Tract as containing approximately 14.124 acres.

N. The 0.002 acreage difference between the acreage of the North Multifamily Tract in the Preliminary Plan when compared to the acreage of the North Multifamily Tract in the Phase 1 Plat represents an acceptable variance that is commonplace in the process of formally platting a subdivision.

O. The redrawing of the boundaries of the North Multifamily Tract included (i) the removal of approximately 0.144 gross acres from the boundaries of the North Multifamily Tract, which land consists of Lot 95, Block H, as depicted in the Phase 1 Plat ("Lot 95") and which the Petitioners intended to be included within the boundaries of Improvement Area #1 of the District and (ii) the addition of approximately 0.405 gross acres of land currently located within the boundaries of the District (as set forth in the Authorization Resolution) to the boundaries of the North Multifamily Tract, resulting in a net increase in the size of the North Multifamily Tract by approximately 0.26 acres.

P. The redrawing of the North Multifamily Tract resulted in the same total number of lots planned within Improvement Area #1, as well as the same projected Assessment (as defined herein) to be levied within Improvement Area #1, as described herein, and, due to an administrative oversight, the Petitioners did not become aware of the resulting boundary discrepancy.

Q. The redrawing of the boundaries of the South Multifamily Tract included (i) the removal of approximately 1.693 gross acres from the boundaries of the South Multifamily Tract and (ii) the addition of approximately 0.090 gross acres of land currently located within the boundaries of the District (as set forth in the Authorization Resolution) to the boundaries of the South Multifamily Tract, resulting in a net decrease in the size of the South Multifamily Tract by approximately 1.603 acres.

R. The redrawn boundaries of the North Multifamily Tract and South Multifamily Tract resulting from the above-described preliminary planning process, and the intended adjustment to the proposed boundary of the District, were inadvertently omitted from the legal description submitted in conjunction with the 2018 Petition.

S. On September 14, 2021, the Commissioners Court adopted a resolution determining the costs of certain public improvements benefiting Improvement Area #1 of the District to be financed through the District, approving the preliminary service and assessment plan, including the proposed assessment roll for Improvement Area #1 of the District (the "Improvement Area #1 Assessment Roll"), calling for a public hearing to consider an order levying assessments on property within Improvement Area #1 of the District (the "Assessments"), authorizing the publication and mailing of notice of a public hearing to consider the levying of the Assessments on certain property within Improvement Area #1 of the District for financing the costs of certain public improvements (the "Improvement Area #1 Improvements") benefiting such property (the "Assessment Public Hearing") in a newspaper of general circulation in the County and the extraterritorial jurisdiction of the City.

T. On September 14, 2021, the Commissioners Court caused the Improvement Area #1 Assessment Roll to be filed with the County Tax Assessor-Collector and the Improvement Area #1 Assessment Roll was made available for public inspection.

U. Pursuant to Section 372.016(b) of the PID Act, the Commissioners Court caused the notice of Assessment Public Hearing to be published on September 17, 2021 in the *Austin American Statesman*, a newspaper of general circulation in the County and the extraterritorial jurisdiction of the City.

V. Pursuant to Section 372.016(c) of the PID Act, the Commissioners Court caused the notice of the Assessment Public Hearing to be mailed to the last known address of the owners of the property liable for the Assessments.

W. On October 5, 2021, the Commissioners Court, after convening a public hearing regarding the levy of the Assessments on benefited property located in Improvement Area #1 and after hearing testimony at such public hearing, adopted an order (the "Assessment Order") approving and accepting the Turner's Crossing Public Improvement District Service and Assessment

Plan (as defined and described in the Assessment Order, the "Service and Assessment Plan") relating to the District and levying the Assessments on the Improvement Area #1 Initial Parcel (as defined in the Service and Assessment Plan) within Improvement Area #1 as shown on the Improvement Area #1 Assessment Roll.

X. Pursuant to the PID Act and the terms of the Service and Assessment Plan, the Commissioners Court is required to annually update the Service and Assessment Plan, including the Improvement Area #1 Assessment Roll (each, an "Annual Service Plan Update").

Y. Lot 95 receives a benefit from the Improvement Area #1 Improvements and was inadvertently included within the Improvement Area #1 Initial Parcel upon which the Assessments were levied.

Z. Pursuant to Section 372.012 of the PID Act, the area within the District to be assessed may not include property not described by the notice as being within the proposed boundaries of the District unless a hearing is held to include the property and notice for the hearing is given in the same manner as notice under Section 372.009 of the PID Act.

AA. It is not clear whether Lot 95 was or was not described in the notice of public hearing relating to the creation of the District due to conflicting descriptions of the boundaries of the District set forth therein; however, the Original Petitioner in its October 2018 Correspondence to the County amended the August 2018 Petition by revising the boundaries of the District to exclude the Multifamily Tracts (Lot 95 being in the North Multifamily Tract prior to it being redrawn), and therefore, Lot 95 was not included within the boundaries of the District as described in the Authorization Resolution.

BB. On July 12, 2022, pursuant to Section 372.012 of the PID Act and upon the written advice of Bond Counsel to the TCDA, the Commissioners Court, by order, determined that the Initial Assessment levied on Lot 95 was invalid, as such land was not included within the boundaries of the District, as set forth in the Authorization Resolution, and released, repealed, and rescinded the Assessment on Lot 95.

CC. The Petitioners discovered the boundary discrepancy described herein in May of 2022, in conjunction with the Petitioners' review of documents associated with the proposed issuance by the Travis County Development Authority of its Contract Assessment Revenue Bonds, Series 2022 (Turner's Crossing Public Improvement District Improvement Area #1 Project) (the "Proposed Bond Issuance").

DD. The Petitioners immediately brought the discrepancy to the attention of counsel for the County, in an effort to correct the discrepancy and ensure accurate representation of information in the documents related to the Proposed Bond Issuance.

EE. On June 28, 2022, Meritage Homes of Texas, LLC, Tri Pointe Homes Texas, Inc., f/k/a Trendmaker Homes, Inc. and Taylor Morrison of Texas, Inc. (collectively, the foregoing parties are referred to herein as the "Petitioners"), as the owners of the taxable real property proposed to be removed or added to the boundaries of the District, submitted and filed with the County Clerk a petition (the "Petition"), requesting that the boundaries of the District be amended to account for the redrawn boundaries of the Multifamily Tracts.

FF. The Petition estimated the total cost of the Authorized Improvements, including the Improvement Area #1 Improvements, for the District to be \$50,000,000 (including issuance and other financing costs).

GG. The Petition (1) has been examined, verified, and found to meet the requirements of Section 372.005 of the PID Act, (2) did not include a request to defer assessment as set forth in Section 372.0055 of the PID Act, and (3) is sufficient for consideration by the Commissioners Court.

HH. The Commissioners Court, by resolution, called a public hearing to be held on amending the boundaries of the District and the advisability of the improvements and services for the District.

II. After publishing notice of the public hearing in *The Austin Chronicle*, a newspaper of general circulation in the County and the extraterritorial jurisdiction of the City, and mailing notice of the public hearing, all as required by and in conformity with the PID Act, the Commissioners Court conducted a public hearing on August 16, 2022 on amending the boundaries of the District and the advisability of the improvements and services for the District.

JJ. All owners of the property located within the land proposed to be removed and the land proposed to be added to the District and all other interested persons were given the opportunity at the public hearing to speak for or against amending the boundaries of the District and the advisability of the improvements and services for the District.

KK. The Commissioners Court closed the public hearing on August 16, 2022.

NOW, THEREFORE, BE IT RESOLVED BY THE COMMISSIONERS COURT OF TRAVIS COUNTY, TEXAS:

SECTION 1. The recitals set forth in this Resolution are true and correct and are incorporated as part of this Resolution for all purposes.

SECTION 2. The Petition submitted to the County was filed with the County Clerk and complies with the PID Act.

SECTION 3. Pursuant to the requirements of the PID Act, including, without limitation, Sections 372.006, 372.009(a), and 372.009(b), the Commissioners Court, after considering the Petition and the evidence and testimony presented at the public hearing on August 16, 2022 hereby finds and declares:

- (a) Advisability of the Proposed Improvements. It is advisable to amend the boundaries of the District to provide the Authorized Improvements (as described below) to the District. The Authorized Improvements are advisable and desirable improvements for the District.
- (b) General Nature of the Authorized Improvements. The purposes of the District include the design, acquisition, construction, and improvement of the Authorized Improvements authorized by the PID Act that are necessary for the development of the District, which Authorized Improvements may include:
 - (1) landscaping;
 - (2) erection of fountains, distinctive lighting, and signs;
 - (3) acquiring, constructing, improving, widening, narrowing, closing, or rerouting of sidewalks or of streets, any other roadways, or their rights-of-way;
 - (4) construction or improvement of pedestrian malls;
 - (5) acquisition and installation of pieces of art;
 - (6) acquisition, construction, or improvement of libraries;
 - (7) acquisition, construction, or improvement of off-street parking facilities;
 - (8) acquisition, construction, improvement, or rerouting of mass transportation facilities;
 - (9) acquisition, construction, or improvement of water, wastewater, or drainage facilities or improvements;
 - (10) the establishment or improvement of parks;
 - (11) projects similar to those listed in (1)-(10);
 - (12) acquisition, by purchase or otherwise, of real property in connection with an authorized improvement;
 - (13) special supplemental services for improvement and promotion of the district, including services relating to advertising, promotion, health and sanitation, water and wastewater, public safety, security, business recruitment, development, recreation, and cultural enhancement;
 - (14) payment of expenses incurred in the establishment, administration, and operation of the District; and
 - (15) the development, rehabilitation, or expansion of affordable housing.
 - (16) payment of expenses under (14) may also include expenses related to the operation and maintenance of mass transportation facilities.

These Authorized Improvements shall promote the interests of the County and are of the nature that will confer a special benefit upon the District, by enhancing the value of such property within the District. The nature of the Authorized Improvements is consistent with the general nature as provided in the Authorization Resolution.

(c) Estimated Costs of the Authorized Improvements Benefitting the District and Apportionment of Costs. The estimated total costs of the Authorized Improvements benefitting the District are \$50,000,000, including issuance and other financing fees, which may be modified to conform to the actual expenses. These costs shall be paid by assessments levied on the District. The estimated total costs of the Authorized Improvements are consistent with the estimated costs provided in the Authorization Resolution. The costs of the Authorized Improvements benefitting the District will be apportioned between the District and the County as allowed by the PID Act. The County will not be obligated to provide any funds to finance the Authorized Improvements benefitting the District, other than from assessments levied on the District. The Petitioners or developer of the Property

(the "Developer") may also pay certain costs of the Authorized Improvements benefitting the District from other funds available to the Petitioners or the Developer, as applicable.

(d) Boundaries of the District. The District is located approximately 1.5 miles east of the intersection of IH-35 and SH-45-SE, within the County and the extraterritorial jurisdiction of the City of Austin, Texas. The amendment to the boundaries of the District include (i) the addition of approximately 0.144 gross acres of land to the boundaries of the District and the removal of approximately 0.405 gross acres of land from the boundaries of the District located north of SH 45, and (ii) the addition of approximately 1.693 gross acres of land to the boundaries of the District and the removal of approximately 0.090 gross acres of land from the boundaries of the District located south of SH 45, all as depicted in Exhibit A. The boundaries of the District, as amended, include approximately 446.732 acres of land, as depicted on the map attached here to Exhibit B and as more particularly described by a metes and bounds description attached hereto as Exhibit C.

(e) Proposed Method of Assessment. Assessments will be levied on the District in a manner that results in imposing equal shares of the costs of the Authorized Improvements on property similarly benefited. The County may levy assessments to pay for the operation, maintenance, and other expenses related to the Authorized Improvements. Any assessments may be paid in full at any time (including interest and principal), and, if not paid in full, may be paid in annual installments (including interest and principal). If an assessment is allowed to be paid in installments, then the installments must be paid in amounts necessary to meet annual costs for those Authorized Improvements financed by the assessments and must continue for a period necessary to retire the indebtedness for those Authorized Improvements (including interest).

SECTION 4. The boundaries of the District are hereby amended, as set forth above, in accordance with Section 372.009 and 372.012 of the PID Act and with the findings of the Commissioners Court as to the advisability of the Authorized Improvements and services benefitting the District contained in this Resolution. The Authorized Improvements benefitting the District are authorized to be made in accordance with the 2022 Annual Service Plan Update to the Service and Assessment Plan.

SECTION 5. Notice of this Resolution authorizing the amendment to the boundaries of the District shall be given by filing a copy of this Resolution with the County Clerk of the County and by publishing this Resolution in a newspaper of general circulation in the County and the extraterritorial jurisdiction of the City.

SECTION 6. County staff is authorized and directed to take any and all actions on behalf of the County necessary or desirable to carry out the intent and purposes of this Resolution.

SECTION 7. It is officially found, determined, and declared that the meeting at which this Resolution is considered is open to the public as required by law, and the public notice of the time, place, and purpose of said meeting was given as required by Chapter 551, Texas Government Code, as amended.

SECTION 8. If any section, article, paragraph, sentence, clause, phrase or word in this resolution or application thereof to any persons or circumstances is held invalid or unconstitutional by a court of competent jurisdiction, such holding shall not affect the validity of the remaining portions of this resolution; and the Commissioners Court hereby declares it would have passed such remaining portions of the resolution despite such invalidity, which remaining portions shall remain in full force and effect.

SECTION 9. The Section headings herein are for convenience only and shall not affect the construction hereof.

SECTION 10. This Resolution and the authorization herein shall be and become effective upon passage and execution hereof.

PASSED AND APPROVED on this, the 16th day of AUGUST, 2022.

TRAVIS COUNTY, TEXAS COMMISSIONERS COURT

Andy Brown
Andy Brown
Travis County Judge

Jeffrey W. Travlun, Sr.
Jeffrey W. Travlun, Sr.
Commissioner, Precinct 1

Brigit Shea
Brigit Shea
Commissioner, Precinct 2

Ane Howard
Ane Howard
Commissioner, Precinct 3

Margaret Gomez
Margaret Gomez
Commissioner, Precinct 4

**EXHIBIT A
MAP DEPICTING THE LAND TO BE ADDED TO THE DISTRICT
AND THE LAND TO BE REMOVED FROM THE DISTRICT**

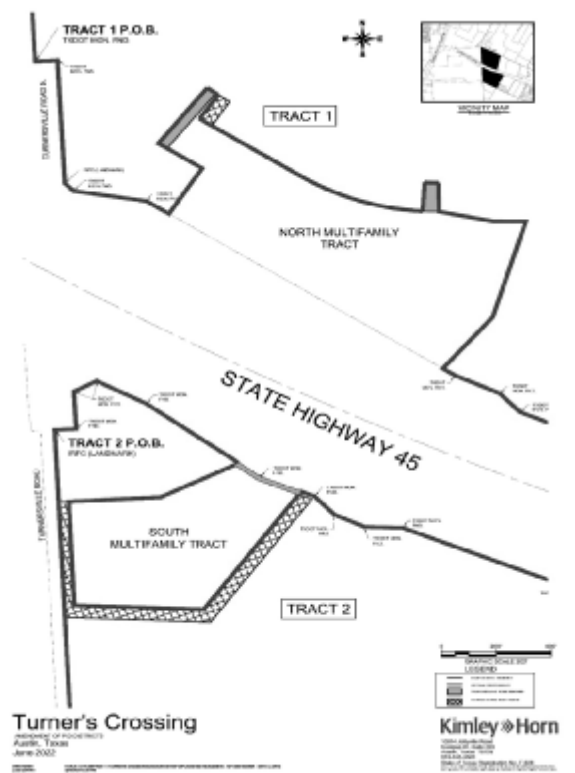

**EXHIBIT B
MAP OF THE BOUNDARIES OF THE DISTRICT**

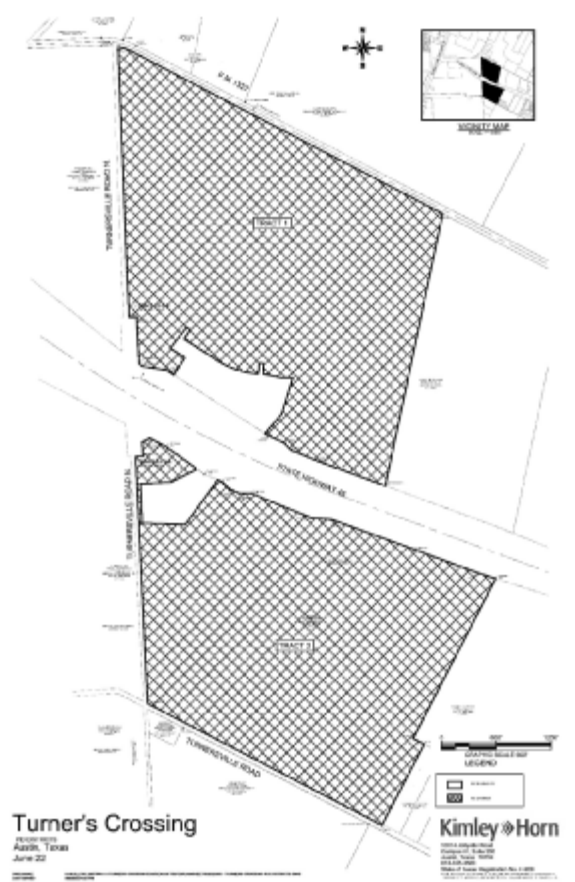

EXHIBIT C
LEGAL DESCRIPTION OF THE BOUNDARIES OF THE DISTRICT

Kimley-Horn and Associates, Inc.
TBPLS Firm No. 10193973
601 NW Loop 410, Suite 350
San Antonio, Texas 78216

Kimley-Horn and Associates, Inc.
TBPLS Firm No. 10193973
601 NW Loop 410, Suite 350
San Antonio, Texas 78216

A METES AND BOUNDS
DESCRIPTION OF A
231.709 ACRE PUBLIC IMPROVEMENT DISTRICT

BEING a 231.709 acre (10,093,223 square feet) tract of land situated in the Elijah Caples Survey, Abstract No. 155, Travis County, Texas, containing a portion of Turner's Crossing North Phase 1 subdivision, plat of which is recorded in Document No. 202100102 of the Official Public Records of Travis County, and a portion of that certain 245.832 acre tract of land described in instrument to Meritage Homes of Texas, LLC, Taylor Morrison of Texas Inc., and Trendmaker Homes Inc. in Document No. 2019099240 of the Official Public Records of Travis County, Texas; and being more particularly described as follows:

BEGINNING at a TXDOT monument found marking the westerly southwest corner of the herein described tract, at the intersection of the northerly right-of-way line of State Highway No. 45 (variable width) with the easterly right-of-way line of North Turnersville Road (variable width);

THENCE, departing the northerly right-of-way line of said State Highway No. 45, and along the easterly right-of-way line of said North Turnersville Road, the following two (2) courses and distances:

1. North 2°40'43" West, 535.14 feet to a 1/2-inch iron rod found for corner;
2. North 2°14'27" West, 2442.36 feet to a 1/2-inch iron rod with a plastic cap stamped "KHA" set at the intersection of the easterly right-of-way line of said North Turnersville Road with the southerly right-of-way line of F.M. 1327 (80 feet wide);

THENCE, departing the easterly right-of-way line of said North Turnersville Road and along the southerly right-of-way line of said F.M. 1327, the following two (2) courses and distances:

1. In a southeasterly direction, along a non-tangent curve to the right having a central angle of 14°41'53", a radius of 676.20 feet, a chord bearing and distance of South 09°45'52" East, 172.99 feet, and a total arc length of 173.47 feet to a 1/2-inch iron rod with a plastic cap stamped "KHA" set at a point of tangency;
2. South 62°24'54" East, 3836.98 feet to a 1/2 inch iron rod (with plastic cap stamped "LANDMARK") found marking the northwesterly corner of a called 100.278 acre tract of land described in instrument to F.M. 1327 Enterprises LP in Document No. 2021157135 of the Official Public Records of Travis County, Texas;

THENCE, South 11°53'06" West, 3066.34 feet departing the southerly right-of-way line of said F.M. 1327 and along the westerly line of said 100.278 acre tract to a 1/2-inch iron rod with a plastic cap stamped "LANDMARK" found on the northerly right-of-way line of aforesaid State Highway No. 45;

THENCE, along the northerly right-of-way line of said State Highway No. 45, the following five (5) courses and distances:

1. North 69°52'23" West, 811.43 feet to a TXDOT monument found for corner;
2. In a northwesterly direction, along a non-tangent curve to the right having a central angle of 1°10'19", a radius of 14518.20 feet, a chord bearing and distance of North 57°22'47" West, 299.01 feet, and a total arc length of 299.01 feet to a TXDOT monument found for corner;
3. North 43°45'32" West, 107.80 feet to a TXDOT monument found for corner;
4. North 85°21'58" West, 180.55 feet to a TXDOT monument found for corner;
5. North 57°18'33" West, 52.16 feet to a point marking the south corner of Lot 95 Multi-family Lot of aforesaid Turner's Crossing North Phase 1;

THENCE, departing the northerly right-of-way line of said State Highway No. 45 and along the boundary of said Lot 95 Multi-family Lot the following fifteen (15) courses and distances:

1. North 40°29'41" East, 281.37 feet to a point for corner;
2. North 16°55'01" East, 414.84 feet to a point for corner;
3. North 89°24'19" West, 120.16 feet to a point for corner;
4. North 78°32'05" West, 201.20 feet to a point for corner;
5. North 1°20'28" West, 120.02 feet to a point for corner;
6. In a northwesterly direction, along a non-tangent curve to the right, a central angle of 88°24'43", a radius of 800.00 feet, a chord bearing and distance of North 58°24'43" West, 40.99 feet, and a total arc length of 60.00 feet to a point for corner;
7. South 3°22'43" West, 120.00 feet to a point for corner;
8. In a northwesterly direction, along a non-tangent curve to the right, a central angle of 29°18'31", a radius of 920.00 feet, a chord bearing and distance of North 71°58'01" West, 465.50 feet, and a total arc length of 470.61 feet to a point of tangency;
9. North 57°18'46" West, 309.77 feet to a point for corner;
10. In a northwesterly direction, along a non-tangent curve to the right, a central angle of 2°33'09", a radius of 1227.54 feet, a chord bearing and distance of North 55°23'00" West, 54.70 feet, and a total arc length of 54.78 feet to a point for corner;
11. North 34°59'00" East, 120.00 feet to a point for corner;
12. In a northwesterly direction, along a non-tangent curve to the right, a central angle of 2°48'04", a radius of 1035.00 feet, a chord bearing and distance of North 53°40'58" West, 50.00 feet, and a total arc length of 50.00 feet to a point of tangency;
13. South 37°42'04" West, 292.50 feet to a point for corner;
14. South 57°18'46" East, 190.45 feet to a point for corner;
15. South 32°41'14" West, 225.06 feet to a point for corner on the northeasterly right-of-way line of aforesaid State Highway No. 45;

THENCE, along the northeasterly right-of-way line of said State Highway No. 45, the following five (5) courses and distances:

1. North 57°18'33" West, 97.88 feet to a TXDOT monument found for corner;
2. North 81°04'19" West, 270.74 feet to a TXDOT monument found for corner;
3. North 44°08'40" West, 45.40 feet to a 1/2 inch iron rod (with plastic cap stamped "LANDMARK") found for corner;
4. North 2°57'59" West, 510.90 feet to a TXDOT monument found for corner;
5. South 87°04'31" West, 82.40 feet to the POINT OF BEGINNING and containing 231.709 acres of land in Travis County, Texas. The basis of bearing for this description is the Texas State Plane Coordinate System Grid, Central Zone (FIPS 4203) (NAD83). All distances are on the Grid and shown in U.S. Survey Feet. This document was prepared in the office of Kimley-Horn and Associates, Inc. in San Antonio, Texas. This document was prepared under 22 TAC §663.21, does not reflect the results of an on the ground survey, and is not to be used to convey or establish interests in real property except those rights and interests implied or established by the creation or reconfiguration of the boundary of the political subdivision for which it was prepared.

A METES AND BOUNDS
DESCRIPTION OF A
215.023 ACRE PUBLIC IMPROVEMENT DISTRICT

BEING a 215.023 acre (9,366,421 square feet) tract of land situated in the William P. Corben Survey, Abstract No. 159, Travis County, Texas; and being a portion of a called 222.714 acre tract of land described in instrument to Meritage Homes of Texas, LLC, Taylor Morrison of Texas Inc., and Trendmaker Homes Inc. in Document No. 2019099240 of the Official Public Records of Travis County, Texas; and being more particularly described as follows:

BEGINNING at a 1/2-inch iron rod with a plastic cap stamped "LANDMARK" found marking the western-most northwest corner of said 222.714 acre tract, at the intersection of the southerly right-of-way line of State Highway No. 45 (variable width) with the easterly right-of-way line of North Turnersville Road (variable width);

THENCE, departing the easterly right-of-way line of said North Turnersville Road and along the southerly right-of-way line of said State Highway No. 45 the following five (5) courses and distances:

1. North 87°09'52" East, 78.16 feet to a TXDOT monument found for corner;
2. North 3°02'16" West, 155.83 feet to a TXDOT monument found for corner;
3. North 62°09'44" East, 94.12 feet to a TXDOT monument found for corner;
4. South 62°37'49" East, 204.30 feet to a TXDOT monument found for corner;
5. South 53°55'35" East, 420.06 feet to a point for corner;

THENCE, crossing said 222.714 acre tract the following five (5) courses and distances:

1. South 63°41'27" West, 320.38 feet departing the southerly right-of-way line of said State Highway No. 45 to a point for corner;
2. South 85°56'45" West, 336.22 feet to a point marking the southwest corner of said 4.562 acre tract;
3. South 2°41'42" East, 432.04 feet to a point for corner;
4. South 87°52'59" East, 473.77 feet to a point for corner;
5. North 35°58'41" East, 606.80 feet to a point for corner on the southerly right-of-way line of said State Highway No. 45;

THENCE, continuing along the southerly right-of-way line of said State Highway No. 45 the following nine (9) courses and distances:

1. South 67°52'36" East, 52.48 feet to a TXDOT monument found for corner;
2. South 43°50'02" East, 106.62 feet to a TXDOT monument found for corner;
3. South 65°18'54" East, 121.55 feet to a TXDOT monument found for corner;
4. South 88°23'42" East, 139.54 feet to a TXDOT monument found for corner;
5. South 67°53'17" East, 715.52 feet to a TXDOT monument found for corner;
6. South 86°10'11" East, 215.41 feet to a TXDOT monument found for corner;
7. South 70°03'00" East, 973.87 feet to a TXDOT monument found for corner;
8. South 69°45'00" East, 754.88 feet to a TXDOT monument found for corner;
9. South 72°28'08" East, 185.43 feet to a TXDOT monument found for corner marking the northwesterly corner of a called 115.77 acre tract of land described in instrument to BGICO, LLC in Document No. 2008058832 of the Official Public Records of Travis County, Texas;

THENCE, departing the southerly right-of-way line of said State Highway No. 45 and along the westerly line of said 115.77 acre tract, the following two (2) courses and distances:

1. South 27°17'46" West, 1976.88 feet to a 3/4-inch iron pipe found for corner;
2. South 62°47'41" East, 136.86 feet to a 1-inch iron pipe found marking the northerly corner of Lot 1 of Turnersville Estates, recorded in Volume 84, Pages 123B-213C of the Plat Records of Travis County, Texas;

THENCE, South 27°27'17" West, 1004.58 feet along the westerly line of said Lot 1 to a 1/2-inch iron rod found on the northeasterly right-of-way line of Turnersville Road (variable width);

THENCE, North 62°31'08" West, 2904.05 feet along the northeasterly right-of-way line of said Turnersville Road to a 1/2-inch iron rod with a plastic cap stamped "LANDMARK" found at the intersection of the northeasterly right-of-way line of said Turnersville Road with the easterly right-of-way line of aforesaid North Turnersville Road;

THENCE, North 2°41'42" West, 2713.89 feet along the said easterly right-of-way line of North Turnersville Road to the POINT OF BEGINNING and containing 215.023 acres of land in Travis County, Texas. The basis of bearing for this description is the Texas State Plane Coordinate System Grid, Central Zone (FIPS 4203) (NAD83). All distances are on the Grid and shown in U.S. Survey Feet. This document was prepared in the office of Kimley-Horn and Associates, Inc. in San Antonio, Texas. This document was prepared under 22 TAC §663.21, does not reflect the results of an on the ground survey, and is not to be used to convey or establish interests in real property except those rights and interests implied or established by the creation or reconfiguration of the boundary of the political subdivision for which it was prepared.



John G. Mosier 6-3-2022
John G. Mosier
Registered Professional Land Surveyor No. 6330
Kimley-Horn and Associates, Inc.
601 NW Loop 410, Suite 350
San Antonio, Texas 78216
Ph. 210-541-9166
greg.mosier@kimley-horn.com



John G. Mosier 6-3-2022
John G. Mosier
Registered Professional Land Surveyor No. 6330
Kimley-Horn and Associates, Inc.
601 NW Loop 410, Suite 350
San Antonio, Texas 78216
Ph. 210-541-9166
greg.mosier@kimley-horn.com

2018 NISSAN 1N4AL3A-P5JC293523 CA \$455.77
2ND NOTICE
2003 TOYOTA 4T1B-F30KX3U560756 CA \$939.65

NOTICE OF ALL PERSONS HAVING CLAIMS AGAINST THE ESTATE OF EDWARD CHARLES LOWDEN

Notice is hereby given that original Letters Testamentary for the Estate of Edward Charles Lowden, Deceased, were issued on August 8, 2022, in Cause No. 22-0241P, pending in the Probate Court No. 3 of Hays County, Texas, to the estate's representative, Lisa Gay Lowden, Independent Executor. All persons having claims against the estate are required to present them within the time required by law. Claims should be addressed in care of the representative's attorney, Gary A. Calabrese, 1301 Nueces Street, Suite 200, Austin, Texas 78701, telephone no. (512) 472-9394. Dated this 22nd day of August, 2022.

NOTICE OF ORDINANCE AN ORDINANCE MAKING APPROPRIATIONS FOR THE SUPPORT OF THE CITY OF MUSTANG RIDGE, TEXAS FOR THE FISCAL YEAR BEGINNING OCTOBER 1, 2022, AND ENDING SEPTEMBER 30, 2023, APPROPRIATING MONEY TO PAY INTEREST AND PRINCIPAL DUE ON THE CITY'S INDEBTNESS AND ADOPTING THE ANNUAL BUDGET OF THE CITY OF MUSTANG RIDGE, TEXAS FOR THE 2022-2023 FISCAL YEAR.

Public Hearing to be held at 6:45 p.m., Monday, September 12, 2022, at City Hall located at 12800 Hwy 183 South, Mustang Ridge, TX 78610
David Bunn, Mayor
City of Mustang Ridge
Attest: Christina Gomez, City Secretary

NOTICE OF ORDINANCE Ordinance # 22-00422 City of Mustang Ridge, Texas Amended Budget Summary Fiscal Year October 1, 2021-September 30, 2022

AN ORDINANCE AMENDING ORDINANCE # 22-00422 MAKING APPROPRIATIONS FOR THE SUPPORT OF THE CITY OF MUSTANG RIDGE, TEXAS FOR THE FISCAL YEAR BEGINNING OCTOBER 1, 2021, AND ENDING SEPTEMBER 30, 2022, APPROPRIATING MONEY TO PAY INTEREST AND PRINCIPAL DUE ON THE CITY'S INDEBTNESS AND ADOPTING THE ANNUAL BUDGET OF THE CITY OF MUSTANG RIDGE, TEXAS FOR THE 2021-2022 FISCAL YEAR. Public Hearing to be held at 6:45 p.m., Monday, September 12, 2022, at the City Hall located at 12800 Hwy 183 South, Mustang Ridge, TX 78610
David Bunn, Mayor
City of Mustang Ridge
Attest: Christina Gomez, City Secretary

NOTICE OF ORDINANCE Ordinance # 22-00424

The City of Mustang Ridge will hold a meeting at 6:45 PM on September 12, 2022, at the City Hall located at 12800 Hwy 183 South, Mustang Ridge, TX 78610 to consider adopting a proposed tax rate for tax year 2022. This Tax Rate will raise more taxes for maintenance and operations than last year's

proposed tax rate. The Tax rate will effectively be raised by 3.5 percent and will raise taxes for maintenance and operations on a \$100,000 Home by approximately \$9.90.

1.) A tax rate of 0.0175 for I & S.
2.) A tax rate of 0.2937 for M & O of the general government (General Fund), and
3.) Any other expenditures as deemed necessary by the City Council.
David Bunn, Mayor
City of Mustang Ridge
Attest: Christina Gomez, City Secretary

NOTICE OF PUBLIC AUCTION

"Pursuant to Chapter 59, Texas Property code, Life Storage locations listed below will hold a public auction of property being sold to satisfy a landlord's lien. Self-storage unit contents of the following customers containing household and other goods will be sold to the highest bidder or otherwise disposed of at a public auction to be held online at www.storage-treasures.com which will end on **Thursday 09/15/2022 at 10:00am. Life Storage #8032 4500 S Congress Ave. Austin, TX 78745**

Courtney Lopez, Joshua Leidich, Oscar Hernandez, Kiara Cabrera, Jovann Parker, Rachel Rivera, Elijah Martin, Crystal Caine, Matthew Reyna

NOTICE OF PUBLIC AUCTION

In accordance with Texas Property Code, Chapter 59, Store It All Storage will conduct a public auction to satisfy a landlord's lien. Units will be sold to the highest bidder online at LockerFox. A \$100 cash clean-up deposit is required. Seller reserves the right to withdraw any unit or not accept any bid at the time of sale. Sale will be held online at lockerfox.com starting on or after August 15, 2022 and ending at 10:00 am on August 29, 2022. Store It All-Del Valle 5280 Hwy 71 East Del Valle, TX 78617 Betty Teague 1G42 Betty Teague 1F78 Betty Teague 1G28 Sasha Vaughan 1G44

NOTICE OF PUBLIC AUCTION

Public Auction at Devon Self Storage, 8008 S Congress Ave Austin, TX 78745
Property contained in the units will be sold to satisfy the Landlord's lien for rent and other charges in accordance with Chapter 59 of the Texas Property Code. Property contained in the units will be sold to the highest bidder via an online auction at www.storage-treasures.com. Online bidding will begin on (9/5/2022) at 10:00AM and will continue until (9/19/2022) at 10:00AM, at which time a high bidder will be determined. Devon Self Storage reserves the right to set minimum bids and to refuse bids. Please refer to www.storage-treasures.com for all other terms and conditions governing the bidding and auction process.
Gerald S Pepper- heavy duty racks
Jessica Nairns - Household Items, Scaffolding

NOTICE OF PUBLIC SALE

Lockerfox.com
In accordance with the Texas

property code, Chapter 59, RightSpace Storage, 9507 Manchaca Road, Austin, TX 78748, will conduct a public auction to satisfy a landlord's lien. Units will be sold to the highest bidder online at Lockerfox.com. A \$100 cash clean up deposit is required. Seller reserves the right to withdraw any unit or not accept any bid at time of sale. Sale will be held online at Lockerfox.com starting on or before 9/1/22 and bidding will close on or after 9/8/22 at 10:00am. General description of contents: general household/ personal goods/ other contents. Names of tenants as they appear on the lease: Timothy Muehleib, Mike Niles, Cindy Delarosa, Christopher Rivers, Maria Delarosa. Tenants may redeem their goods for full payment in cash or money order only up to time of auction. Call RightSpace Storage at 512-382-0994.

NOTICE OF PUBLIC SALE

Lockerfox.com
In accordance with the Texas property code, Chapter 59, RIGHTSPACE STORAGE, LOCATED AT 227 PARK 35 COVE N, BUDA, TX 78610, will conduct a public auction to satisfy a landlord's lien. Units will be sold to the highest bidder online at Lockerfox.com. A \$100 cash clean up deposit is required. Seller reserves the right to withdraw any unit or not accept any bid at time of sale. SALE WILL BE HELD ONLINE AT LOCKERFOX.COM STARTING ON OR BEFORE AUGUST 19, 2022 AND BIDDING WILL CLOSE ON OR AFTER SEPTEMBER 8, 2022 AT 10:00AM. General description of contents: general household/personal goods/ other contents. ALEAH FISHER AND JOE MARTINEZ. Tenants may redeem their goods for full payment in cash or money order only up to time of auction. Call RightSpace Storage at 512-295-2701.

NOTICE OF PUBLIC SALE

Lockerfox.com
In accordance with the Texas property code, Chapter 59, RightSpace Storage 4405 Highway 71 east, Del Valle Texas, 78617 will conduct a public auction to satisfy a landlord's lien. Units will be sold to the highest bidder online at Lockerfox.com. A \$100 cash clean up deposit is required. Seller reserves the right to withdraw any unit or not accept any bid at time of sale. Sale will be held online at Lockerfox.com starting on or before 9/1/22 and bidding will close on or after 9/8/22 at 10:00am. General description of contents: general household/ personal goods/ other contents. Names of tenants as they appear on the lease, Victor Mendez, Bertha Deleon, Jeremiah Gray, Blanca Loredo, Johnny Vasquez. Tenants may redeem their goods for full payment in cash or money order only up to time of auction. Call RightSpace Storage at 512-969-7349.

NOTICE OF PUBLIC SALE

Pursuant to Chapter 59 of the Texas Property Code, TJO 10 X 10 Management, Ltd Managing properties listed below will hold a public auction of property being sold to satisfy a landlord's lien. The sale will begin on or about the time

indicated at www.selfstorage-auction.com. Property will be sold to highest bidder for cash. Deposit for removal and cleanup may be temporarily required. Seller reserves the right to reject any bid and to withdraw property from sale. Property may be sold by the space. Property being sold includes contents in spaces of following tenants, with brief description of contents in each space.

Wednesday, September 14, 2022

12:00 pm ATX Self Storage @ 6901 N. I-35, Austin, TX 78752
www.SelfStorageAuction.com

John Christopher: misc. items.
John Christopher: misc. items.
Michael Foley: misc. items.
Cronii Gambol: misc. items.
Cristina Gomez: misc. items.
Veronica Guerra: misc. items.
Deleon Manor: misc. items.
Lawrence Moseley: misc. items.
Phillip Osuji: misc. items.
Steven Rice: misc. items.
Karyn Vila: misc. items.
Satchel Williams: misc. items.

12:00 pm Bergstrom Storage @ 530 Bastrop Hwy SB, Austin, TX 78741
www.SelfStorageAuction.com

Linda Williams: misc. items.
Jesusita Zapata: misc. items.
12:00 pm Lakeline Storage @ 11000 Lakeline Blvd, Austin, TX 78717
www.SelfStorageAuction.com

Jay Young: misc. items.
Angela Hammack: misc. items.
Elliott Guilbe: misc. items.
12:00 pm Oak Hill Storage @ 7901 W. Hwy 71, Austin, TX 78735
www.SelfStorageAuction.com

Dawn Burns: misc. items.
12:00 pm My Attic Self Storage @ 1602 W. Pecan St. Pflugerville, TX 78660
www.SelfStorageAuction.com

Robert Lee: misc. items.
Angel Lara-Martinez: misc. items.
Alishia Parsons: misc. items.
Alawiya Wani: misc. items.
Alicia Barton: misc. items.
Marylin Carson: misc. items.
Candice Courtney: misc. items.
David C Mcgee: misc. items.
Sherrye Price: misc. items.
Alison Wiseman: misc. items.
12:00 pm Northgate Storage @ 8833 Research Blvd, Austin, TX 78758
www.SelfStorageAuction.com

Anthony Collins: misc. items.
Brandi Herbeck: misc. items.
Antonio De Escobar Neto: misc. items.
Edward Zihlman: misc. items.
Coby Harris: misc. items.
Edward Zihlman: misc. items.
Marco Bustos: misc. items.
Julie Lawson: misc. items.
Phillip Robinson: misc. items.

NOTICE OF PUBLIC SALE

Pursuant to Chapter 59 of the Texas Property Code: **STORAGE STAR, POND SPRINGS** located at 13444 POND SPRINGS RD, AUSTIN, TX 78729 will hold a public auction of property being sold to satisfy a landlord's lien. The sale will begin at 1:00 PM on **September 23, 2022**. Property will be sold to the highest bidder for CASH. Deposit for removal and

CONTINUED ON P.68

NOTICE OF PUBLIC HEARING TO CONSIDER PROPOSED ASSESSMENTS TO BE LEVIED AGAINST PROPERTY LOCATED IN THE TURNER'S CROSSING PUBLIC IMPROVEMENT DISTRICT

NOTICE IS HEREBY GIVEN THAT a public hearing will be conducted by the Commissioners Court of Travis County, Texas on September 13, 2022 at or after 9:00 a.m. at the Travis County Administration Building, Commissioners Courtroom, 700 Lavaca St., First Floor, Austin, Texas 78701.

The public hearing will be held to consider proposed assessments to be levied against the assessable property within Lot 95, Block H ("Lot 95") of Improvement Area #1 of the Turner's Crossing Public Improvement District (the "District") pursuant to the provisions of Chapter 372 of the Texas Local Government Code, as amended (the "PID Act"). The proposed public improvements (the "Improvement Area #1 Improvements") to be undertaken at this time include roadway and sidewalk improvements, water distribution system improvements, sanitary sewer collection system improvements, and storm drain facilities.

The total estimated cost of the Improvement Area #1 Improvements allocable to Lot 95 is \$43,745, including soft costs, District formation costs, financing costs, and contingency costs.

The boundaries of Lot 95 include approximately 0.144 acres and consist of Lot 95, Block H within the Turner's Crossing North -- Phase 1, a subdivision in Travis County, Texas, according to the map or plat thereof recorded in Document Number 202100102 of the Official Public Records of Travis County, Texas, all of which is located in the County and the extraterritorial jurisdiction of the City of Austin, Texas, as depicted on the map attached hereto as Exhibit A.

All written or oral objections on the proposed assessments within Lot 95 will be considered at the public hearing.

A metes and bounds description of the boundaries of Lot 95 and a copy of the preliminary amended and restated service and assessment plan, including the proposed Updated Improvement Area #1 Assessment Roll relating to the costs of the Improvement Area #1 Improvements benefitting Lot 95, which includes the assessments to be levied on the assessable property within Lot 95 that benefits from the Improvement Area #1 Improvements, can be obtained by contacting the Travis County Office of Economic Development & Strategic Investments Director, by email at EDSi@traviscountytx.gov or by U.S. mail at P.O. Box 1748, Austin, Texas 78767.

**EXHIBIT A
Map of Lot 95**



NOT FADE AWAY

O B I T U A R I E S + M E M O R I A L S



STEVEN EDWARD LEONARD (1952-2022)

STEVEN E. LEONARD Kyle, TX – Steven E. Leonard, 69, passed away peacefully on August 8th, 2022.

On September 12, 1952, a warm summer day announced the birth of an extraordinary, son of Lee Edward & Ruth Leonard. During his years at Lamar Consolidated High School, Steve excelled in baseball. After graduating high school in 1971, Steve attended Sam Houston State University (SHSU), where he cultivated his passion for photography. After graduating from SHSU in 1979, he began his career as a professional photographer, where he quickly became the pre-eminent photographer in the Ft. Bend County area. High School graduations and weddings were his specialty. Later in life, Steve grew to love the Real Estate business and became a realtor in the Central Texas area.

During his free time, Steve found joy through his participation in several charitable organizations including AFSUSA, Habitat of Humanity and New Life UpBring. Steve was also a Director of the Central Texas Golf Association, a member of the Sons of the Republic of Texas Moses Austin Chapter and Mission City Golf Association.

Steve's fervent interest in other people along with his unique and outgoing personality, cultivated an unprecedented number of friends and acquaintances. These connections led him to a variety of interests including hunting, fishing, snow skiing and golf. Later in life he privately developed deep faith and a prolific knowledge of the Bible.

What Steve cared for the most, was his family. He is survived by his daughter, Katelyn Leonard; mother, Ruth Leonard; siblings, Ben Leonard, Scott Leonard and wife Tammy, Carole Davis and husband Donnie; numerous nieces, nephews, other relatives and many friends.

Memorial service pending and will be posted to facebook.com/katelyn.leonard.14. Relatives and friends are invited to share memories and stories during the service by dropping a letter in a collections box located near the entrance.

In lieu of flowers please consider sending donations to UpBring located at upbring.org



Not Fade Away is The Austin Chronicle's section for obituaries, memorials, and notices of death. For information on rates, rules and deadlines, please contact 512-302-2755.

LEGAL NOTICES CONTINUED FROM P.67

cleanup may be temporarily required. Seller reserves the right to not accept any bid and to withdraw property from sale. Property being sold includes contents in spaces of following tenants, with brief description of contents in each space. Dates of publication: **1st: 8/26/22 2nd: 9/2/22**
Rudy Arrendondo
Rickey Gonzales- Construction material, ac unit, file cabinet shelving, mattress
Rickey Gonzales- Building materials, labels
Shirley Steele Townes- Chairs, clothing, tables, shelf, cooler,boxes
Alex Guthrie- Tools, ladder, home goods, car seat
Alex Goggins- Bikes, totes, coolers, scooter, tires
Stacey Stastny- Tables, totes,

boxes, hides
Submitted by: Andrew Losh @ Storage Star
Address: 13444 Pond Springs Road Austin TX 78729
City: Austin, State: TX Zip: 78729
Phone: 512-335-1500
Email: spondsprings@storagestar.com

NOTICE OF PUBLIC SALE
Security Self Storage, under Chapter 59 of the Texas Property Code, hereby gives Notice of Sale under Said Act, to wit: On SEPTEMBER 15, 2022 at 2 P.M. at 10210 N Lamar, Austin, TX 78753, Security Self Storage will conduct a sale on Lockerfox.com prior to the sale date for each unit in its entirety to the highest bidder for cash,

of the contents of the following units to satisfy a landlord's lien, Seller reserves the right to refuse any bid and to withdraw any property from sale. The public is invited to bid on said units.
Jeremy French: fridge, boat, furniture, speaker, coffee maker, vacuums. Alana Puentes: ice chests, shelving, dishes, portable gas stoves, tables, totes. Judy Golden: microwaves, clothing, chairs, totes, dresser, shelving. Lucia Puentes: totes, briefcases, kid toys, boxes. Tina Briseno: chest, boxes, kid toys, bedding. Hermina Chavez: wheelchair, bird cage, boxes, furniture, Christmas décor, bedframe, misc. Brand Hammond: table saw, file cabinet, shop vac, shelving, tools, motorcycle

seat, misc. Jose DeJesus Rodriguez Flores: power tools, tent, dishes, extension ladder, ice chest, air compressor, jack hammer, engine, fridge.

NOTICE OF PUBLIC SALE - of property to satisfy landlords lien. The sale will be conducted on StorageAuctions.com and will be sold to the highest bidder for cash on/or after 9/6/2022 at 3:00 pm
Seller reserves the right to withdraw property from sale. Property includes contents of spaces at Southpark Storage 2229 E. ben white blvd, Austin TX 78741
Robert Powell
Household items, furniture, 2002 Black Mercedes CP CLS VIN # WDBPJ75J02A027989
9910 Slaughter Creek Dr. Austin, TX 78748, 737.346.8417, September 9, 2022 at 11:00am

and clothes
Zack Barlet (wander Jaunt) bed slatts boxes with books ceiling fan box lighting boxes pillow boxes
Zack Barlet (wander Jaunt) small metal tables in box small metal chairs in box bed slatts and bed frames new memory pads mattresses
Zack Barlet (wander Jaunt) furniture boxes rugs and pillows Samaria Richardson bags of cloths and bags
chris Mathews tools bags tote and buckets
Patricia Arzola party supplies arts and crafts
Questions can be addressed to the property manager David Collier @ 512-368-1461 southparkstorage512@gmail.com

NOTICE OF PUBLIC SALE OF PERSONAL PROPERTY
Notice is hereby given that Storage Direct Cedar Park, located at 945 W New Hope Dr Cedar Park TX 78613, will hold a Public Sale, to satisfy the lien of the owner. Units will be sold via online auction, at www.StorageTreasures.com. Bidding will begin at 10am on **08/26/2022** and auction will close at or after 10am on **09/02/2022**. The personal goods stored therein by the following may include, but are not limited to general household, toys, boxes, clothes and misc.
Name: Kathleen Harman Unit 730 Kathleen Harman Unit 729 You must be 18 to bid online. Purchases must be made with cash (no checks accepted) and paid at the time of sale, plus any applicable sales tax. Buyers must provide a current copy of their resale permit to avoid sales tax. A \$100 cash cleaning deposit is required at time of purchase. All goods are sold AS IS and must be removed within 72 hours of the time of purchase. Property grants all entries and exits to access unit won, no gate code is provided. Shelving is property of the owner and may not be removed. Owner reserves the right to bid and the right to refuse bids. Sale is subject to cancellation.

NOTICE OF PUBLIC SALE of property to satisfy landlord's lien per chapter 59 (Texas property code). The sale will be conducted on StorageAuctions.com and will be sold to the highest bidder for cash on/or after **September 3rd, 2022 at 3PM**. Seller reserves the right to withdraw property from sale. Property includes contents of spaces at **East Central Storage 853 Airport Blvd, Austin, TX 78702**. Questions can be addressed to the property manager, **Kim Vacker 512-385-1222 or email storageeastcentral512@gmail.com**
Unit: 021- Nancy Williams: Household items, misc totes & boxes, personal items

NOTICE OF PUBLIC SALE of property to satisfy landlord's lien. The sale will be conducted on <https://storageauctions.com/> and will be sold to the highest bidder for cash on **Sept 5, 2022, at 2:00 PM**. Seller reserves the right to withdraw property from sale. Property includes contents of spaces at A Mini Storage of Texas, 2381 Hwy 71 East, Del Valle, TX 78617: Household and other goods-construction equipment, furniture, and office furniture. Questions, call manager @ 512-582-0300.
Jessica Daulton- TOTS,Bags Harry Flores Perales Jr-Tools,boxes
Joashua Mills- tools,tot Elizabeth Perez-Dolls, lamp Amanda Reynolds-boxes, Leha Rizzo- Fan,chair

NOTICE OF PUBLIC SALE: Self-storage Cube contents of the following customers containing household and other goods will be sold for cash to satisfy a lien on September 7th, 2022 at approx. 12:00 PM at www.storage-treasures.com: **Store 707- CubeSmart 2501 Dies Ranch Road, Cedar Park, TX 78613:** Brian Coffman, Justin Medrano, Steven Murphy, Joshua Cedars, Summer Cates, Martin Rangel Jr; **Store 748 - CubeSmart 12006 Ranch Road 620 N, Austin, TX 78750:** Amari Williams, Sonia Bracey, Stephen J Guilbeau, Stephanie T Cordova, Robert K Bustamante, Nicholas Kaina Macias, Shari Lynn Buttler; **Store 793 - CubeSmart 2220 E Riverside**

Michael Darling 1620 S. IH-35 Frontage Rd. Austin, TX 78704, 512.298.1737, September 9, 2022 at 11:30am Elizabeth Torres Richard Acosta
1000 E. 50th St. Austin, TX 78751, 512.501.1131, September 9, 2022 at 11:45am
Alexis Kostun Boxes, small household items Randall Castro
5500 W. Hwy 290 Dripping Springs, TX 78620, 512.600.7060, September 9, 2022 at 12:00pm
Larry Stauffer Heath Hineline
The auction will be listed and advertised on www.storage-treasures.com. Purchases must be made with cash only and paid at the above referenced facility in order to complete the transaction. Extra Space Storage may refuse any bid and may rescind any purchase up until the winning bidder takes possession of the personal property.

Dr. Austin, TX 78741: Jose Cantu, David Ghali, Michael Regino, Janel Carter, Tony Hogue, Sarah Kahloun, Courtney Marriott Austin Airport, Flecty Cardenas, Jose La Placa Amigo, Jorge Arguello, Jacob N Rice, Carlos Garcia; **Store 794 - CubeSmart 2201 S Pleasant Valley Rd, Austin, TX 78741:** Anthony York, Jo A Ward, Andrea Ybarra, Gabriel A Parra, Tyrone Raspberry, Sarah Witek, Cara Boniface, Ethan A Mince, Zachary P Cain, Devin Robinson, Elry Pozo, Justin Stidham, Kevin Baugh, Silvano Castellanos, Desmond Bonsignore, Francisco Javier Garcia Llanas; **Store 795- CubeSmart 1905 E William Cannon Dr, Austin, TX 78744:** Armando Santiago, Sandra Yvonne Hughes, IVIRRUTH CHABLE MORALES, Jose Gomez, Candice Fortenberry, TRACY HERNANDEZ, Kimberly Lopez, Miguel Martinez Gonzalez, Kimberly Hernandez, Jacqueline Termino, Loriann Arias, Paul Gilmore, Jesse Mott; **Store 910 - CubeSmart 2525 S IH-35 Frontage Rd, Austin, TX 78741:** James Kevin Parks, Joel Rios, Corey Farrell, Michelle Ricks, Ariana A Mendoza, Melissa Bane; **Store 914 - CubeSmart 4900 Ranch Road 620N, Austin, TX 78732:** Raul Vela, Tamesha Clanton, Marc Geronimo; **Store 917 - CubeSmart 6130 East Ben White Blvd, Austin, TX 78741:** Larry Demon Goodman Jr. Shayne T Negri, Laura Roebuck, Mia Alexandra Pettill, Sara Esther Arango Garcia, Christopher Dakota Southerland, Audrey Deshion Parks, Kemberlyn Sarahi Rubio Cardona, Ruben Parado, Delores Ceballos, Katie Chasco, Amy N Ximenez, Sara Arango, Willie Amanda Johnson, Aloha K Seda, Richard Espinoza; **Store 4491 - CubeSmart 1411 W 5th Street, Austin, TX 78703:** Tristan Farley, Kirby Chandler, Matthew Gallagher, Roy Sosa, Jorge Saenz, Alexander Meza, Jason Schulte, Andrew Seibert; **Store 4653 - CubeSmart 5656 N IH-35, Austin, TX 78751:** Solomon Thomas, Allyson McManners, Kristopher Rodriguez, Vanessa Roberts, Gage Kemp, Ashwanee Barrett, Deloris Harrison, John Morales, Sierra Johnson; **Store 5417 - CubeSmart 5715 Burnet Rd, Austin, TX 78756:** Anderson Broberg, Ping-Ju Hsieh, Miles Eliot French, John Wesley French Jr, Maureen Elizabeth McFee, Oya N Foster; **Store 5418 - CubeSmart 2701 South Congress Ave, Austin, TX 78704:** Andrea N Bell, Lisa Schilling-Ramirez, Kevin Fox, Jake Kurtzhalmz, Phillip Miles, John Clark Miller Jr, Darius D King; **Store 5965 - Bee Safe 510 South IH-35, Round Rock, TX 78664:** Javan Smith, Taina Tipton, Jacqueline Thompson, James Smith, Holly Crain; **Store 5968 - Bee Safe 1405 North I-35, Round Rock, TX 78664:** Tyrone Jones, Rodrigo Garci, Ignacio Lobaton, Chris Trageser, Juan Lopez, Justus J Huston, Vielka Marie Vasquez; **Store 6304 - CubeSmart 15615 Stewart Road, Lakeway, TX 78734:** Danielle Livings; **Store 6758 - Bee Safe 1205 Wells Branch Parkway, Pflugerville, TX 78660:** Mackenzie Morrison, Jamila John, Raul Nino Nino, Cesar Vences, San JL Reyna, Aubrey Jackson JR, Tenisha

NOTICE OF PUBLIC SALE: Self-storage Cube contents of the following customers containing household and other goods will be sold for cash by CubeSmart to satisfy a lien on 09/14/2022 at approx. 9:30AM at www.storage-treasures.com: **10025 Manchaca Rd, Austin, TX 78748:** Christine King **610 E Stassney Ln, Austin, TX 78745:** Adan C Garcia II, Albert T. Palazese, Roland Estrada, Monica Alvarado, Rae Lindley, Rolsa Claverie, Robyn Bowerman, Joseph Walsh, Nicholas Messenger **701 Philomena Dr, Kyle, TX 78640:** Micheal C Phillips, Chase C Baromeo, Arturo Ramirez, Kevin Farrell **21400 Interstate 35, Kyle, TX 78640:** Jakob Greenwalt, Brian Cortez, Refugio Guevara, Jacob Franco, Trish Foster, Tracie Robinson, Hector Castro **5141 Cromwell Dr, Kyle, TX 78640:** Stephanie M Martinez, Jason Lee Weber, Chris Hyatt, Natividad II Olvera, Henry Valdez **510 West SH-71, Bastrop, TX 78602:** Vanessa Uranga, Jehu Rodriguez, Azucena Hernandez, Misty Buck, Tanisha Jenkin, Becca Davis, Edgar Anderson.

NOTICE OF PUBLIC SALE: Self-storage Cube contents of the following customers containing household and other goods will be sold for cash to satisfy a lien on September 14th, 2022 at approx. 12:00 PM at www.storage-treasures.com: **CubeSmart 10707 N IH35 Austin TX 78753:** Vincetta Green, Kevin Harris, Edith McCoy, Kiara Brown, Lauryn Gonzales, Kristina Robinson, Jacovan Hollins, Coleton Avery, Joseph Rojas, Kylene S James, John Anderson **CubeSmart 1301 NE Inner Loop, Georgetown, TX 78626:** Chadley Jackson, Sonia Mendiola, Daniel R Underwood **CubeSmart 244 Benelli Dr Hutto TX 78634:** Kayla Hackney, Teresa Ledbetter **CubeSmart 2220 E Howard Ln Pflugerville TX 78660:** Irving Jones, Ketriska Phillips, John Billy, Christine L Jones, Jaqueline Fabian **CubeSmart 400 N HWY 183 Liberty Hill TX 78642:** James Kett, Crystal Lynn Murray **CubeSmart 3901 Shell Rd Georgetown TX 78628:** Shane Thompson **CubeSmart 3706 N Main St Taylor TX 75704:** Jacky Jones, Tyrianna Zachary, Kristin West, Rindy L. Hutto, Justin Medrano, Amy M Lee, Katherine Coe, David Torres, Janean Asbury, Catherine Carmichael, Richard Flowers, Traci Urbanski, Mary Gomez, Joshua Anderson, Aaron S Mills **CubeSmart 13601 Dessau Rd Pflugerville TX 78660:** Ariel Zimmerman, Charlotte Nelson, Jacquata Crump, Ashley Barron **CubeSmart 2701 FM 1460 Georgetown TX 78626:**

Celestial Tobias **CubeSmart 14509 Owen Tech Blvd Austin TX 78728**: Robert Barnes, Quanisha Hamilton, Gladys Bonney, Beverly D Dukes, Daniel Molina, Tina Chapman, Schlyer Davis, Aerial Johnson **CubeSmart 2400 N Austin Ave Georgetown TX 78626**: Newel Briggs **CubeSmart 646 W Front St Hutto TX 78634**: Rebecca Sandoval, Christina Roman, Michael Neal, Ted Diaz, Will Thigpen, LaMarqus Polk, Patricia Baker **CubeSmart 110 S FM 1660 Hutto TX 78634**: Andres Sanchez, Andres A Sanchez, Ryan Ming **CubeSmart 8023 W Parmer Ln Austin TX 78729**: Milton Johnson Jr., Zineb Benkirane, Jasmine Mason, Anne Elizabeth Cognetti, Terry Johnson, Elvia Garza, Keith Franklin, Ashley Quintanilla, Jazmine C Haney

NOTICE OF SALE

Notice is hereby given that a public sale will be held at **Mini U Storage** (formerly Wells Branch Self Storage), 1763 **Wells Branch Parkway, Austin, TX 78728 on September 15, 2022 at 11:00 AM** to satisfy a landlord's lien on the property stored at the address above in the units listed pursuant to Texas Property Code, Chapter 59. Tenants notated the inventories listed at the time of rental. Landlord makes no representation or warranty that the units contain said inventories. **MUMPHORD, JERMAINE B203**

Misc. Household **MORENO, ELLIE B316**
Misc. Household **BARNETT, TRACY B518**
Misc. Household, Personal Effects **CORTEZ, JOHN C428**
Misc. Household **VERNER, JAYSON C613**
Misc. Household, Personal Effects **PRUITT, JEREMY C621**
Misc. Household, Personal Effects **JACKSON, MIA D103**
Misc. Household **BALTIERREZ, SANTIAGO D308**

Misc. Household, Personal effects **WELLS, AMIR D406**
Misc. Household **POWELL, GREGORY D605**
dressers, beds, boxes **Nelson, Christie D623**

Misc. Household, Personal Effects
All units must be paid for at the time of sale. Cash only will be accepted. No one under the age of 18 is allowed to attend the sale. Each person attending must sign in and agree to follow all Rules and Regulations of the sale. The landlord reserves the right to bid at the sale. All purchased goods are sold "as is" and must be removed within 48 hours following the sale. Shelving is property of landlord; do not remove unless authorized. Buyers must provide a current, original or a photocopy of their original resale permit at time of sale in lieu of sales tax. This sale is subject to cancellation in the event of settlement

between landlord and obligated party.

NOTICE OF SALE OF PERSONAL PROPERTY

Extra Space Storage will hold a public auction to satisfy Extra Space's lien, by selling personal property described below belonging to those individuals listed below at the location indicated. All spaces contain household furniture unless otherwise noted. **6512 McNeil Dr. Austin, TX 78729 9/09/22 10:00 AM**
Earl Wayne Thomas
James Waits
12506 N. Lamar Blvd Austin, TX 78753 9/09/22 10:30 AM
Kourtney Miller
Miken Guerrero
Christina Lopez
Christian Nzegwu
Henry Rowley
11800 Hero Way W. Leander, TX 78641 9/09/22 11:30 AM
Zachary Montgomery
Cesar Funez
13126 Ranch Rd 620 N. Austin, TX 78717 9/09/22 12:30PM
Jorge Zamora

The auction will be listed and advertised on www.storageet-researches.com. Purchases must be made with cash only and paid at the above referenced facility in order to complete the transaction. Extra Space Storage may refuse any bid and may rescind any purchase up until the winning bidder takes possession of the personal property.

NOTICE TO ALL PERSONS HAVING CLAIMS AGAINST THE ESTATE OF EDWIN BURTON EUBANKS

On August 18, 2022, letters testamentary for the Estate were issued to Carol Ellen Wood, by Probate Court No. 1 of Travis County, Texas, in Cause Number C-1-PB-22-001519 pending upon the Probate Docket of said Court.
All persons having claims against the Estate, which is currently being administered, should present those claims within the time prescribed by law to:
Sara H. Atkins
Attorney for Carol Ellen Wood, Independent Executor
7800 N. Mopac Expwy, Suite 200
Austin, Texas 78759

NOTICE TO ALL PERSONS HAVING CLAIMS AGAINST THE ESTATE OF HARLEY E. EATON A/K/A HARLEY EARL EATON, DECEASED

Notice is hereby given that original Letters Testamentary for the Estate of **Harley E. Eaton a/k/a Harley Earl Eaton**, Deceased, were issued on August 17, 2022 in Cause No. C-1-PB-22-001430, pending in the Probate Court No. One of Travis County, Texas, to **Leah Jo Eaton**.
Claims may be presented in care of the attorney for the estate, addressed as follows: **Leah Jo Eaton**, Independent Executor
Estate of **Harley E. Eaton a/k/a Harley Earl Eaton**, Deceased
c/o Pamela Hailey-Petty, Attorney for Independent Executor
13740 Research Blvd., Suite V4
Austin, Texas 78750
All persons having claims against this estate, which is currently being administered, are required to present them within the time and in the manner prescribed by law.
DATED: August 26, 2022.

Hailey-Petty Law Firm, PLLC
Pamela Hailey-Petty, Attorney

NOTICE TO ALL PERSONS HAVING CLAIMS AGAINST THE ESTATE OF JANICE E. STONER, AKA, JANICE STONER

On August 18, 2022, Letters Testamentary for the Estate were issued to Thomas C. Stoner by the Probate Court No.1, Travis County, Texas, in Cause Number C-1-PB-22-000511, pending upon the Probate Docket of said Court.
All persons having claims against the Estate, which is currently being administered, should present those claims within the time prescribed by law to:
Gregory S. Kazen
Attorney for Thomas C. Stoner, Independent Executor of the Estate of Janice E. Stoner, aka Janice Stoner
The Warren Law Firm
1100 West Avenue
Austin, Texas 78701

NOTICE TO ALL PERSONS HAVING CLAIMS AGAINST THE ESTATE OF MICHAEL RAYMOND NECHAY A/K/A MIKE NECHAY, DECEASED

Notice is hereby given that original Letters of Independent Administration for the Estate of **Michael Raymond Nechay a/k/a Mike Nechay**, Deceased, were issued on August 23, 2022 in Cause No. C-1-PB-22-001035, pending in the Probate Court No. One of Travis County, Texas, to **Steven M. Nechay**.
Claims may be presented in care of the attorney for the estate, addressed as follows: **Steven M. Nechay**, Independent Administrator
Estate of **Michael Raymond Nechay a/k/a Mike Nechay**, Deceased
c/o Pamela Hailey-Petty, Attorney for Independent Administrator
13740 Research Blvd., Suite V4
Austin, Texas 78750
All persons having claims against this estate, which is currently being administered, are required to present them within the time and in the manner prescribed by law.
DATED: August 26, 2022.
Hailey-Petty Law Firm, PLLC
Pamela Hailey-Petty, Attorney

NOTICE TO ALL PERSONS HAVING CLAIMS AGAINST THE ESTATE OF AMY SUSAN GRIMES, DECEASED

Notice is hereby given that original Letters of Administration for the Estate of **Amy Susan Grimes**, Deceased, were issued on August 11, 2022 in Cause No. C-1-PB-21-001598, pending in Travis County Probate Court Number One, to: **Yvonne Kimmons**, Independent Administrator. The residence of the Independent Administrator is Austin, Texas. The post office address for claims is: Estate of **Amy Susan Grimes** Law Office of Diane Hebner 507 West 7th Street Austin, TX 78701-2831
All persons having claims against this Estate which is currently being administered are required to present them within the time and in the manner prescribed by law.
DATED August 11, 2022.
LAW OFFICE OF DIANE HEBNER
507 West 7th Street

Austin, TX 78701-2831
(512) 477-4158 Telephone
By: /s/ Diane Hebner
Diane Hebner
State Bar No. 09367300
Attorney for Independent Administrator

NOTICE TO ALL PERSONS HAVING CLAIMS AGAINST THE ESTATE OF ANNA L. HANS, DECEASED

Notice is hereby given that original Letters Testamentary for the Estate of ANNA L. HANS, Deceased, were issued August 19, 2022, in Cause No. C-1-PB-22-001509, pending in Probate Court No. 1 of Travis County, Texas, to HAROLD B. HANS, SR. The notice to the Independent Executor may be delivered at the following address: c/o John M. Lane Law, PLLC – 1001 Cypress Creek Road, Suite 405, Cedar Park, Texas 78613. All persons having claims against this Estate which is currently being administered are required to present them within the time and in the manner prescribed by law. HAROLD B. HANS, SR, Independent Executor of the Estate of ANNA L. HANS, Deceased.

NOTICE TO ALL PERSONS HAVING CLAIMS AGAINST THE ESTATE OF CHRISTINA A. KIEN

Notice is hereby given that original Letters Testamentary for the Estate of Christina A. Kien, Deceased, were issued on August 16, 2022, in Cause No. C-1-PB-22-001494, pending in Probate Court #1 in Travis County, Texas, to the Estate's Independent Executor, Arthur H. Boutin. All persons having claims against this Estate which is currently being administered are required to present them to the undersigned within the time and in the manner prescribed by law. Claims should be addressed in care of the representative's attorney, Benjamin K. Williams, Esq., 10119 Lake Creek Pkwy, Suite 201, Austin, Texas 78729. Dated this the 17th day of August, 2022.

NOTICE TO ALL PERSONS HAVING CLAIMS AGAINST THE ESTATE OF JAY LOUIS CAPLAN, DECEASED

On August 16, 2022, letters testamentary as Independent Executor for the Estate were issued to Jessica Caplan Sabharwal by Probate Court No. One of Travis County, Texas, in Cause Number C-1-PB-22-001013 pending upon the Probate Docket of said Court.
All persons having claims against the Estate, which is currently being administered, should present those claims within the time prescribed by law to:
Russell E. Booth,
Attorney for Jessica Caplan Sabharwal, Independent Executor
2901 Bee Cave Road, Building O
Austin, Texas 78746

NOTICE TO ALL PERSONS HAVING CLAIMS AGAINST THE ESTATE OF JOAN H. McLINDEN a/k/a JOAN ELIZABETH McLINDEN, DECEASED

Notice is hereby given that original Letters Testamentary for the Estate of Joan H. McLinden

a/k/a Joan Elizabeth McLinden, Deceased, were granted on the 18th day of August, 2022, in Cause No. C-1-PB-22-001450, pending in the Probate Court No. 1 of Travis County, Texas, to:
KAREN ELIZABETH McLINDEN
The mailing address for the Independent Executor is: Karen Elizabeth McLinden, Independent Executor
Estate of Joan H. McLinden a/k/a Joan Elizabeth McLinden, Deceased
Attention: Brooke Hardie
c/o HARDIE ALCOZER, PLLC
1607 Nueces Street
Austin, Texas 78701
All persons having claims against this Estate, which is currently being administered, are required to present them within the time and in the manner prescribed by law.
DATED this 26th day of August, 2022.

NOTICE TO ALL PERSONS HAVING CLAIMS AGAINST THE ESTATE OF JOHN L. SMITH, DECEASED

Notice is hereby given that original Letters Testamentary for the Estate of JOHN L. SMITH, Deceased, were issued August 23, 2022, in Cause No. C-1-PB-22-001266, pending in Probate Court No. 1 of Travis County, Texas, to BEVERLY J. LEE. The notice to the Independent Executor may be delivered at the following address: c/o John M. Lane Law, PLLC – 1001 Cypress Creek Road, Suite 405, Cedar Park, Texas 78613. All persons having claims against this Estate which is currently being administered are required to present them within the time and in the manner prescribed by law. BEVERLY J. LEE, Independent Executor of the Estate of JOHN L. SMITH, Deceased.

NOTICE TO ALL PERSONS HAVING CLAIMS AGAINST THE ESTATE OF MARGARET RUTH KNOX, DECEASED

Notice is hereby given that original Letters Testamentary for the Estate of Margaret Ruth Knox, Deceased were issued to the following named person on August 9, 2022, in Cause No. C-1-PB-22-000844, pending in the Probate Court No. One of Travis County, Texas: Patricia Partridge
The residence of such Executor is Bastrop County, Texas. The mailing address is set forth below:
The Law Practice of Robin T. Cravey
P.O. Box 41016
Austin, Texas 78704
All persons having claims against this Estate, which is currently being administered, are required to present them within the time and in the manner prescribed by law.
DATED this day, August 12, 2022
Respectfully submitted,
/s/ Robin T. Cravey
Robin T. Cravey,
Attorney for Independent Executor
Patricia Partridge

NOTICE TO ALL PERSONS HAVING CLAIMS AGAINST THE ESTATE OF NANCY JANE HUSTACE, DECEASED

Notice is hereby given that original Letters Testamentary for the Estate of NANCY JANE HUSTACE, Deceased, were issued on August 16, 2022, in Cause No. C-1-PB-22-001444

pending in the Travis County Probate Court No. 1, Travis County, Texas to John Alwyn Hustace as Independent Executor. The residence of the Independent Executor is in Travis County, Texas. The post office address for claims is: Estate of NANCY JANE HUSTACE, Deceased
Gilman & Associates, PC.
1524 S. IH-35, Suite 218
Austin, TX 78704-2600
All persons having claims against this Estate which is currently being administered are required to present them within the time and in the manner prescribed by law.
Dated: August 17, 2022
Gilman & Associates, PC.
1524 S. IH-35, Suite 218
Austin, TX 78704-2600
Attorneys for the Executor

NOTICE TO ALL PERSONS HAVING CLAIMS AGAINST THE ESTATE OF RAYMOND BLAKE MERRILL, DECEASED

Notice is hereby given that original Letters Testamentary for the Estate of RAYMOND BLAKE MERRILL, Deceased, were issued August 18, 2022, in Cause No. C-1-PB-22-001166, pending in Probate Court No. 1 of Travis County, Texas, to FRANK HARRISON MERRILL. The notice to the Independent Executor may be delivered at the following address: c/o John M. Lane Law, PLLC – 1001 Cypress Creek Road, Suite 405, Cedar Park, Texas 78613. All persons having claims against this Estate which is currently being administered are required to present them within the time and in the manner prescribed by law. FRANK HARRISON MERRILL, Independent Executor of the Estate of RAYMOND BLAKE MERRILL, Deceased.

NOTICE TO ALL PERSONS HAVING CLAIMS AGAINST THE ESTATE OF RICHARD DAVID HUSETH, DECEASED

Notice is hereby given that original Letters Testamentary for the Estate of Richard David Huset, Deceased, were issued on August 16, 2022, in Cause No. C-1-PB-22-001742, pending in the Probate Court Number One of Travis County, Texas, to Deborah Jo Bandera. The Independent Executor resides in Austin, Texas, and may be contacted through her attorney, Elizabeth Daniel Law, PLLC, 1801 East 51st Street, Suite 365-502, Austin, TX 78723. All persons having claims against the estate, which is being administered, are required to present them within the time and in the manner prescribed by law. Dated August 17, 2022.

NOTICE TO ALL PERSONS HAVING CLAIMS AGAINST THE ESTATE OF ROBERT CISNEROS, DECEASED

Notice is hereby given that original Letters Testamentary for the Estate of Robert Cisneros, Deceased, were issued on August 11, 2022, in Cause No. C-1-PB-21-002681, pending in the Probate Court Number One of Travis County, Texas, to Theresa S. Cisneros. The Independent Executor resides in Austin, Texas, and may be contacted through her attorney, Elizabeth Daniel Law, PLLC, 1801 East 51st Street, Suite 365-502, Austin, TX 78723. All persons having claims against the estate, which is being

administered, are required to present them within the time and in the manner prescribed by law. Dated August 17, 2022.

NOTICE TO ALL PERSONS HAVING CLAIMS AGAINST THE ESTATE OF THOMAS MICHAEL DAVIS

On August 18, 2022, letters of independent administration with will annexed for the Estate were issued to Thomas Benjamin Davis (a/k/a Ty Davis) by Probate Court No. 1 of Travis County, Texas, in Cause Number C-1-PB-22-001158 pending upon the Probate Docket of said Court.

All persons having claims against the Estate, which is currently being administered, should present those claims within the time prescribed by law to:
Reid Powers
Attorney for Thomas Benjamin Davis (a/k/a Ty Davis), Independent Administrator
With Will Annexed
2630 Exposition Blvd., Suite 203
Austin, Texas 78703-1763

NOTICE TO ALL PERSONS HAVING CLAIMS AGAINST THE ESTATE OF VIRGINIA ELIZABETH WALKER

Notice is hereby given that original Letters of Independent Administration with Will Annexed for the Estate of VIRGINIA ELIZABETH WALKER, Deceased, were issued on August 18, 2022, to JANET E. PARKS in Cause No. C-1-PB-22-001409, pending in the Probate Court No.1, Travis County, Texas. All persons having claims against this Estate that is currently being administered are required to present them within the time prescribed by law. Claims may be presented in care of the representative's attorney addressed as follows: Representative, Estate of **VIRGINIA ELIZABETH WALKER**, Deceased, c/o **THE GREENING LAW FIRM, P.C.**, 506 West 15th Street, Austin, Texas 78701.

NOTICE TO CREDITORS

Notice is given that original Letters of Independent Administration for the Estate of Francisco Rosales, Jr. were issued on 08/18/2022, in docket number C-1-PB-21-002119, pending in the Statutory Probate Court Number 1 of Travis County, Texas, to Jamie Rosales. All persons having claims against the estate, which is presently being administered, are required to submit them, within the time and manner prescribed by law, and before the estate is closed, addressed as follows:

Representative
Estate of Francisco Rosales, Jr.
c/o Samantha Yantz
13809 Research Blvd.
Suite 640
Austin, TX 78750
Dated 08/18/2022
By: /s/ Samantha Yantz
Samantha Yantz
Attorney for Administrator of the Estate of Francisco Rosales, Jr.

NOTICE TO CREDITORS

Notice is hereby given that original Letters of Administration for the Estate of Ronald Alan Hansen, Deceased, were issued on August 16, 2022, in Cause No. 22-0158-CP4, pending in the County Court of Williamson County in Matters Probate, Texas, to: Christopher

Hansen
All persons having claims against this Estate which is currently being administered are required to present them to the undersigned within the time and in the manner prescribed by law.
c/o: Christopher Hansen
3279 Hwy 8
Rhinelander, WI 54501
DATED August 26, 2022
MIKE MASSEY LAW, PLLC
Glenda C. Claussell
State Bar No.: 24065051
418 Grace Lane
Austin, TX 78746
Telephone: (888) 407-3021
Facsimile: (512) 729-7819
E-mail: glenda@mytxwillis.com
ATTORNEY FOR CHRISTOPHER HANSEN

NOTICE TO CREDITORS

NOTICE IS HEREBY GIVEN that original Letters of Independent Administration for the Estate of CHRISTOPHER THOMAS JEANE, Deceased, were issued on August 19, 2022, in Cause No. 22-0731-CP4, pending in the County Court at Law No. 4 of Williamson County, Texas, to: I. LYNN JEANE, A/K/A ISAAC LYNN JEANE.
All persons having claims against this Estate which is currently being administered are required to present them to the undersigned within the time and in the manner prescribed by law.

I. LYNN JEANE, A/K/A ISAAC LYNN JEANE, Independent Administrator, Estate of CHRISTOPHER THOMAS JEANE c/o Rashmi P. Krishnappa
August 19, 2022
The Law Offices of Kyle Robbins, PLLC
3800 N. Lamar Blvd., Suite 200
Austin, Texas 78756
Telephone: (512) 851-1248
Attorney for Independent Administrator

NOTICE TO CREDITORS

Notice is hereby given that original Letters of Independent Administration of the Estate of Mark Evan Loewe were issued on August 18, 2022 in Cause No. C-1-PB-22-001102, by the Travis County Probate Court Number One to Susie Kang, Independent Administrator of the Estate of Mark Evan Loewe. All persons having claims against said Estate are required to present them to Richard Thormann, Attorney at Law, 805 W. 10th Street, Suite 100, Austin, Texas 78701 within the time prescribed by law.

NOTICE TO CREDITORS

Notice is hereby given that original Letters Testamentary for the Estate of Angela Romagosa, Deceased, were issued on August 15, 2022, under Case No. C-1-PB-22-000721, pending in the Probate Court Number One, Travis County, Texas to Suzette Nicole Neyra Hendrick, Independent Executor. Claims may be presented in care of the attorney for the executor of the estate, addressed as follows: Suzette Nicole Neyra Hendrick, Independent Executor
Estate of Angela Romagosa, Deceased
c/o Noel L. Stout
2301 S. Capital of Texas Highway, Building H-101
Austin, Texas 78746.

NOTICE TO CREDITORS

NOTICE is hereby given that

CONTINUED
ON P.70

FREE WILL ASTROLOGY

by Rob Breznsny for August 26 - September 1

VIRGO (Aug. 23-Sept. 22): Whenever you are contemplating a major decision, I hope you raise questions like these: 1. Which option shows the most self-respect? 2. Which path would be the best way to honor yourself? 3. Which choice is most likely to help you fulfill the purposes you came to earth to carry out? 4. Which course of action would enable you to express your best gifts? Are there questions you would add, Virgo? I expect the coming months will require you to generate key decisions at a higher rate than usual, so I hope you will make intensive use of my guiding inquiries, as well as any others you formulate.

LIBRA (Sept. 23-Oct. 22): Libran blogger Ana-Sofia Cardelle writes, "I look back on past versions of myself with such love and tenderness. I want to embrace myself at different parts of my life." I hope you're inspired by her thoughts as you carry out the following actions: 1. Create an altar filled with treasures that symbolize major turning points in your destiny. 2. Forgive yourself for what you imagine to be old errors and ignorance. 3. Summon memories of the persons you were at ages 7, 12, and 17, and write a kind, thoughtful message to each. 4. Literally kiss seven different photos of your face from earlier in your life. 5. Say "thank you" and "bless you" to the self you were when you succeeded at two challenging tests in the past.

SCORPIO (Oct. 23-Nov. 21): You know more about how karma works than all the other signs. Scorpio-style intelligence typically has a fine intuitive grasp of how today's realities evolved out of the deep patterns and rhythms of the past. But that doesn't mean you perfectly understand how karma works. And in the coming weeks, I urge you to be eager to learn more. Become even savvier about how the law of cause and effect impacts the destinies of you and your allies. Meditate on how the situations you are in now were influenced by actions you took once upon a time. Ruminates on what you could do in the near future to foster good karma and diminish weird karma.

SAGITTARIUS (Nov. 22-Dec. 21): Kabbalistic writer Simon Jacobson says, "Like a flame, the soul always reaches upward. The soul's fire wants to defy the confines of life. It cannot tolerate the mediocrity and monotony of sheer materialism. Its passion knows no limits as it craves for the beyond." That sounds both marvelous and hazardous, right? Jacobson concludes, "Whether the soul's fire will be a constructive or destructive force is dependent on the person's motivation." According to my astrological analysis, your deep motivations are likely to be extra noble and generous in the coming weeks, Sagittarius. So I expect that your soul's fire will be very constructive.

CAPRICORN (Dec. 22-Jan. 19): In the Spanish language, there's the idiom *pensando en la inmortalidad del cangrejo*. Its literal translation is "thinking about the immortality of the crab." It applies to a person engaged in creative daydreaming - her imagination wandering freely in hopes of rousing innovative solutions to practical dilemmas. Other languages have similar idioms. In Finnish, *istun ja mielin syntymä syviä* means "wondering about the world's early origins." Polish has *marzyć o niebieskich migdałach*, or "dreaming about blue almonds." I encourage you to enjoy an abundance of such explorations in the coming days, Capricorn. You need to fantasize more than usual.

AQUARIUS (Jan. 20-Feb. 18): My Aquarian reader George Lee wrote to tell me what it's like being an Aquarius. I offer it to you because you are potentially at the peak of expressing the qualities she names. She says, "Accept that you don't really have to understand yourself. Be at peace with how you constantly ramble, swerve, and weave to become more of yourself. Appreciate how each electric shift leads to the next electric shift, always changing who you are forever. Within the churning, ever-yearning current, marvel at how you remain eternal, steady, and solid - yet always evolving, always on a higher ground before."

PISCES (Feb. 19-March 20): Here's a good way build your vibrancy: Use your emotional intelligence to avoid swimming against strong currents for extended periods. Please note that swimming against strong currents is fine, even advisable, for brief phases. Doing so boosts your stamina and fosters your trust in your resilience. But mostly, I recommend you swim in the same direction as the currents or swim where the water is calm and currentless. In the coming weeks, I suspect you can enjoy many freestyle excursions as you head in the same direction as vigorous currents.

ARIES (March 21-April 19): In the coming weeks, I urge you to flee from stale and rigid certainty. Rebel against dogmatic attitudes and arrogant opinions. Be skeptical of unequivocal answers to nuanced questions. Instead, dear Aries, give your amused reverence to all that's mysterious and enigmatic. Bask in the glimmer of intriguing paradoxes. Draw inspiration and healing from the fertile unknown. For inspiration, write out this Mary Oliver poem and carry it with you: "Let me keep my distance, always, from those who think they have the answers. Let me keep company with those who say 'Look!' and laugh in astonishment, and bow their heads."

TAURUS (April 20-May 20): A blogger named Chaconia writes, "I've cultivated a lifetime of being low maintenance and easy-going, and now I've decided I'm done with it. Demanding Me is born today." I'm giving you temporary permission to make a similar declaration, Taurus. The astrological omens suggest that in the coming weeks, you have every right to be a charming, enchanting, and generous version of a demanding person. So I authorize you to be just that. Enjoy yourself as you ask for more of everything.

GEMINI (May 21-June 20): The witch Lisa Chamberlain writes about the magical properties of colors. About brown, she says it "represents endurance, solidity, grounding, and strength." She adds that it's used in magic to enhance "balance, concentration, material gain, home, and companion animals." According to my reading of the astrological omens, the upcoming weeks should be a deeply brown time for you Geminis. To move your imagination in a righteous direction, have fun wearing clothes in shades of brown. Grace your environment with things that have the hues of chestnut, umber, mahogany, sepia, and burnt sienna. Eat and drink caramel, toffee, cinnamon, almonds, coffee, and chocolate.

CANCER (June 21-July 22): Cancerian poet Danusha Laméris discovered that earthworms have taste buds all over their bodies. Now she loves to imagine she's giving them gifts when she drops bits of apples, beets, avocados, melons, and carrot tops into the compost bin. "I'd always thought theirs a menial life, eyeless and hidden, almost vulgar." But now that she understands "they bear a pleasure so sublime," she wants to help the worms fulfill their destinies. I mention this, Cancerian, because I suspect you may have comparable turnarounds in the coming weeks. Long-held ideas may need adjustments. Incomplete understandings will be filled in when you learn the rest of the story. You will receive a stream of interesting new information that changes your mind, mostly in enjoyable ways.

LEO (July 23-Aug. 22): You should never allow yourself to be tamed by others. That advice is always apropos for you Leos, and even more crucial to heed in the coming weeks. You need to cultivate maximum access to the raw, primal sources of your life energy. Your ability to thrive depends on how well you identify and express the beautiful animal within you. Here's my only caveat: If you imagine there may be value in being tamed a little, in harnessing your brilliant beast, do the taming yourself. And assign that task to the part of you that possesses the wildest wisdom.

PARK & HOMER puzzles

Change

Puzzle by J. Reynolds

No. 754

Across

1. Super Bowl XXXIV champs
5. Government agents
9. Panama, e.g.
14. Australian export
15. "...way to skin"
16. Boxing site
17. Woolworth's e.g.
19. Guinness, e.g.
20. Garden tool
21. Hatchling's home
23. Ave. crossers
24. Equipment
27. Face-off
29. Gen. Robert
32. Flirt with
34. Convenience
38. Costa del
39. Breakfast, lunch or dinner
40. Magic Johnson was one
41. Shortly after quitting time, for many
45. Minneapolis-to-Fargo hwy.
46. Places for holsters
47. "Wait a ___!"
48. Checked out
49. Arcade name
51. "___ that special?!"
52. Identical
54. Rebounds, e.g.
56. Baseball's Ripken
59. Reaction to bad news
61. Some big trucks
65. Got out of bed

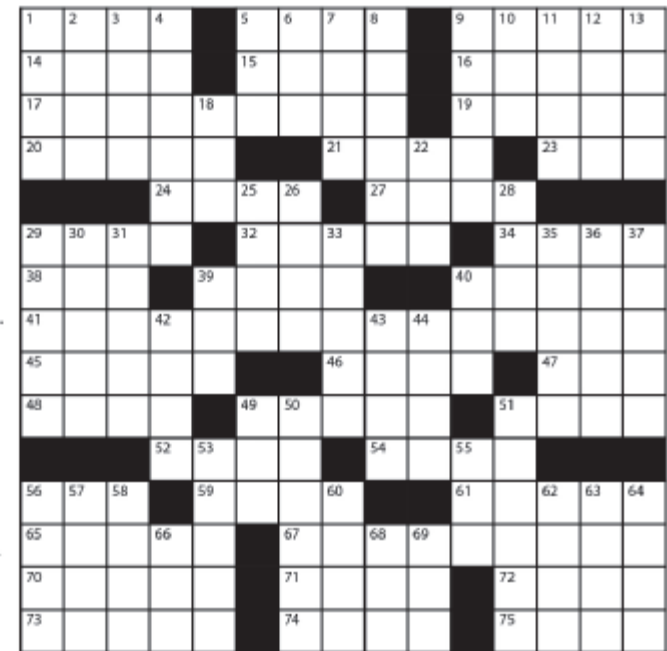

67. Where "all the people that come and go stop and say hello"
70. Mob scenes
71. Black-and-white treat
72. Flatten, in a way
73. Takes out
74. Preschoolers
75. Street fleet

9. Hindu social division
10. Gallery display
11. Modernists
12. "Sometimes you feel like ___"
13. Back muscles, for short
18. "What'd I tell ya?"
22. Seek damages
25. Suit to ___
26. Bring up
28. Fall faller
29. Suffix with Roman
30. Rotten
31. Fill with joy
33. Primary
35. "Sealed with ___"
36. Brad Pitt thriller
37. Not slouching
39. Atlas abbr.
40. Capt.'s inferiors
42. Cincinnati team

Down

1. Fishing gear
2. "You're ___!" (Archie Bunker comment)
3. Cry from a crib
4. Heavy hammer
5. Blubber
6. Green: Prefix
7. "Phooey!"
8. War horses

43. Broadcasts
44. Rod at a pig roast
49. I love: Lat.
50. Bag holder
51. Slanted
53. "Don't make ___!"
55. One of Alcott's "Little Women"
56. King or queen
57. Soprano's song, maybe
58. Plunder
60. Claudius's successor
62. Irene of "Fame"
63. Door opener
64. D.C. figures
66. Jeanne d'Arc, e.g.: Abbr.
68. Court divider
69. Rejections

SEE THIS WEEK'S PUZZLE SOLUTION AT WWW.AUSTINCHRONICLE.COM/CROSSWORD

LEGAL NOTICES CONTINUED FROM P.69

original Letters Testamentary for the Estate of Ann Stephens a/k/a Anna Belle Delores Stephens, Deceased, were issued on August 9, 2022, in Cause No. C-1-PB-22-001294, pending in Probate Court No. 1 of Travis County, Texas, to: B. Royce

Stephens. All persons having claims against this Estate which is currently being administered are required to present them within the time and in the manner prescribed by law. The notice to the Independent Executor may be delivered at the

following address: c/o Kristin F. Baird, Attorney at Law, 9600 Escarpment Blvd., Suite 745-159, Austin, Texas 78749, Dated the 22nd day of August, 2022. /s/ Kristin F. Baird, Kristin F. Baird, Attorney for Independent Executor

NOTICE TO CREDITORS
Notice is hereby given that original Letters Testamentary for the Estate of Christos Panagiotis Petropoulos, Deceased, were issued on August 18, 2022, in Cause No. C-1-PB-22-001424,

Go to RealAstrology.com to check out Rob Breznsny's EXPANDED WEEKLY AUDIO HOROSCOPES and DAILY TEXT MESSAGE HOROSCOPES. The audio horoscopes are also available by phone at 877/873-4888 or 900/950-7700.

MARKETPLACE

2022 MERCEDES SPRINTER VAN Brand new - travel in style - Sleeping quarters, small kitchen area. \$150,000 OBO (303) 870-8614 chodge@sagapetroleum.com

AUTO CASH FOR CARS! We buy all cars! Junk, high-end, totaled - it doesn't matter! Get free towing and same day cash! NEWER MODELS too! Call 866-535-9689 (AAN CAN)

BATH & SHOWER UPDATES in as little as ONE DAY! Affordable prices - No payments for 18 months! Lifetime warranty & professional installs. Senior & Military Discounts available. Call 1-866-370-2939 (AAN CAN)

DEBT RELIEF Credit Card Debt Relief! Reduce payment by up to 50%! Get one LOW affordable payment/month. Reduce interest. Stop calls. FREE no-obligation consultation Call 1-855-761-1456 (AAN CAN)

DIRECT TV DirecTV Satellite TV Service Starting at \$74.99/month! Free Installation! 160+ channels available. Call Now to Get the Most Sports & Entertainment on TV! 877-310-2472 (AAN CAN)

DISH TV 64.99 For 190 Channels + \$14.95 High Speed Internet. Free Installation, Smart HD DVR Included, Free Voice Remote. Some restrictions apply. Promo Expires 1/21/23 1-866-566-1815 (AAN CAN)

ED Attention Viagra users: Generic 100 mg blue pills or generic 20 mg yellow pills. Get 45 plus 5 free \$99 + S/H. Call Today 1-877-707-5517 (AAN CAN)

FREON WANTED FREON WANTED: Certified buyer looking to buy R11, R12, and R500 and more. Call Xiomara at 312-313-9671. (312) 291-9169

GUITARS TOP CASH PAID FOR OLD GUITARS! 1920-1980 Gibson, Martin, Fender, Gretsch, Epiphone, Guild, Mosrite, Rickenbacker, Prairie State, D'Angelico, Stromberg, And Gibson Mandolins / Banjos. 877-589-0747 (AAN CAN)

GUTTERS Never clean your gutters again! Affordable, professionally installed gutter guards protect your gutters and home from debris and leaves forever! For a FREE Quote call: 999-999-9999 (AAN CAN)

HOME INTERNET 4G LTE Home Internet Now Available! Get GoW3 with lightning fast speeds plus take your service with you when you travel! As low as \$109.99/mo! 1-866-571-1325 (AAN CAN)

INTERNET Spectrum Internet as low as \$29.99, call to see if you qualify for ACP and free internet. No Credit Check. Call Now! 833-955-0905 (AAN CAN)

MEDICAL BILLING TRAIN ONLINE TO DO MEDICAL BILLING! Become a Medical Office Professional online at CTI! Get Trained, Certified & ready to work in months! Call 866-243-5931. (M-F 8am-6pm ET). Computer with internet is required. (AAN CAN)

RAILROADS AROUND AUSTIN "Then and Now" book showing past and present views of railroads around Austin over the last 150 years. Great present for anyone interested in history. www.railroadsaroundaustin.com or on Amazon or BookPeople book store OBO kevinformby2810@gmail.com

SATELLITE INTERNET HughesNet Satellite Internet - Finally, no hard data limits! Call Today for speeds up to 25mbps as low as \$59.99/mo! \$75 gift card, terms apply. 1-866-544-5758 (AAN CAN)

TAXES ARE YOU BEHIND \$10k OR MORE ON YOUR TAXES? Stop wage & bank levies, liens & audits, unfiled tax returns, payroll issues, & resolve tax debt FAST. Call 877-414-2089 (Hours: Mon-Fri 7am-5pm PST) (AAN CAN)

WATCHES PAYING TOP CASH FOR MEN'S SPORT WATCHES! Rolex, Breitling, Omega, Patek Philippe, Heuer, Daytona, GMT, Submariner and Speedmaster. Call 888-320-1052 (AAN CAN)

WATER DAMAGE Water Damage to Your Home? Call for a quote for professional cleanup & maintain the value of your home! Set an apt today! Call 833-664-1530 (AAN CAN)

MIND / BODY

FREE COVID-19 IMMUNIZATIONS Author: Any Bridges Don't miss out on the next FREE COVID-19 event! Jump start National Wellness Month with your immunization on the following dates: August 3rd at Ebenezer Church 7 pm,

August 9th at Greater Love Church 7 pm, and August 27th at Givens Recreation Center 10 am - noon. The University of Texas Nurses and Black Nurses Association will be happy to serve you and schedule any future appointments!

GENERAL Treat yourself to a relaxing hot oil, full-body Swedish massage in a candle-lit, private room/shower, 24/7, in/out calls. Clint 775-9164 - LMT # 34842

MUSIC

AUSTIN HARMONICA LESSONS Austin Harmonica Teacher. Michael Rubin michaelrubinharmonica.com 512-619-0761 Skype/Facetime lessons available

REAL ESTATE

CENTRAL 4 BR/4.5 BA New home in Twin Forks Estates, Leakey, Tx gated community, 4 bedroom 4.5 bathrooms 1799 sq.ft. Private trail that leads you to the Frio River \$599,000 (830) 374-7901 Marykay@highplacesrealty.com

OTHER Hill Country Custom Home 4 BR/3.5 BA 4bd/3.5ba/2.5cg 3,600 sq ft 2050 Summit Crest, Kerrville, Texas 830-469-2009 Agent (830) 343-7093 Agent

SCAM ALERT Use caution when accepting payments over the listed amount. Please take action to verify authenticity of all check and money order transactions prior to completion of sale.

pending in the Probate Court # 1, Travis County, Texas, to: Michelle Valenzuela. Claims may be presented in care of the attorney for the estate, addressed as follow: Michelle Valenzuela Estate of Wilbert Lee Pickens, Jr., Deceased c/o: Hunt Pennington Kumar, PLLC 609 Castle Ridge Rd., Ste. 315 Austin, TX 78746

All persons having claims against this Estate which is currently being administered are required to present them to the undersigned within the time and in the manner prescribed by law.

DATED the day of August 17, 2022. /s/ Artie Pennington Artie Pennington Attorney for Michelle Valenzuela

State Bar No.: 24090324 Hunt Pennington Kumar, PLLC 609 Castle Ridge Road, Ste. 315 AUSTIN, TX 78746 Telephone: (512) 766-6082 Facsimile: (512) 233-2699 E-mail: aapennington@hpkfirm.com

NOTICE TO CREDITORS Notice to all persons having claims against the Estate of Shari Lynn Riddle, Deceased. Notice is hereby given that Derek Painter was appointed Independent Administrator of the Estate of Shari Lynn Riddle, Deceased, and original Letters of Independent Administration were issued to Derek Painter on August 16, 2022, in Cause No. C-1-PB-22-001138, in the Probate Court No. 1 of Travis County, Texas, which matter is still pending. All persons having claims against said Estate are required to present same within the time prescribed by law to: Derek Painter at 550 County Road 458, No. 200, Coupland, Texas 78615.

NOTICE TO CREDITORS On August 18, 2022, Steven FG Swenson was appointed to serve without bond as Independent Executor of the Will and Estate of Zack Swenson Deceased, in Cause No. **C-1-PB-22-001507**, pending in the Probate Court, Court No. 1, Travis County, Texas. The address of Independent Executor is c/o Andrew C. Friedmann, Attorney & Counselor at Law, 4408 Spicewood Springs Road, Austin, Texas 78759, and all persons having claims against this estate are required to present them to such address in the manner and time required by law.

NOTICE TO CREDITORS Notice is hereby given that original Letters of Independent Administration upon the Estate of GENNA CATHERINE GAUNA, Deceased, were issued to Diana M. Fiermonte, whose residence is in Austin, Texas, on the 11th day of August, 2022, in Travis County Probate Court, which is still pending. All persons having claims against the Estate being administered are

required to present the same within the time prescribed by law. Address claims to: Mr. Franklin L. Tuttle, Jr. NAMAN, HOWELL, SMITH & LEE, PLLC 8310 Capital of Texas Highway North Suite 490 Austin, Texas 78731 Dated this 15th day of August, 2022. /s/ Franklin L. Tuttle, Jr. NAMAN, HOWELL, SMITH & LEE/PLLC By: Franklin L. Tuttle, Jr. State Bar No. 20349200 Attorney for Applicant

NOTICE TO CREDITORS AGAINST THE ESTATE OF NICHOLAS L. RHEE

On the 12th day of July, 2022, Letters of Dependent Administration for the Estate of NICHOLAS L. RHEE, Deceased, were issued to KEITH MORRIS by the Probate Court No. One of Travis County, Texas, in cause number C-1-PB-22-000926 pending upon the docket of said Court.

All persons having claims against this Estate are hereby required to present them within the time and manner prescribed by law at the address shown below. The name where claims may be sent is Keith Morris, whose address is 777 Main St., Ste. 550, Fort Worth, Texas 76102, Office 817-334-0066 /s/ Keith Morris, TX Bar Number 24032879.

OFFICIAL PUBLIC NOTICE TO BIDDERS

TRAVIS COUNTY, TEXAS Notice is hereby given that sealed bids will be accepted by Travis County for the following items: 1. Flood Warning & Detection System, RFP# 2206-005-TM Opens: September 13, 2022 Pre-Proposal Conference - August 31, 2022 See RFP for details 2. Countywide Janitorial Services, IFB #2208-009-WL Opens: September 5, 2022, at 9:00 A.M. 3. County Auto Body Repairs, IFB# 2207-003-MH Opens: September 5th, 2022, at 12:00 P.M.

Bids should be submitted to: Bonnie Floyd, Travis County Purchasing Agent, 700 Lavaca Street, Suite 800, P.O. Box 1748, Austin, Texas 78767. Specifications can be obtained from or viewed at the Travis County Purchasing Office at no charge or by downloading a copy from our website: www.traviscountytx.gov/purchasing/solicitation. Bidders should use unit pricing or lump sum pricing, if appropriate. Payments may be made by check. The successful bidder shall be required to furnish a Performance Bond in the amount of One Hundred percent (100%) of the contract amount awarded, if applicable.

PUBLIC STORAGE NOTICE Lockerfox.com In accordance with the Texas property code, Chapter 59, RightSpace Storage 11520 Hero Way W, Leander Texas 78641 will conduct a public auction to satisfy a landlord's lien. Units will be sold to the highest bidder online at Lockerfox.com. A \$100 cash clean up deposit is required. Seller reserves the right to withdraw any unit or not accept any bid at time of sale. Sale will be held online at Lockerfox.com starting on or before August 26, 2022 and bidding will close on or after September 8, 2022 at 10:00am. General description of contents: general household/personal goods. Names of tenants as they appear on the lease: Elizabeth Slater, Jim Schaffner, Adela Obregon. Tenant(s) may redeem their goods for full payment in cash or money order only up to time of auction. Call RightSpace Storage at 512-528-6025.

RIGHTSPACE STORAGE AUCTION NOTICE Lockerfox.com In accordance with the Texas property code, Chapter 59, RightSpace Storage 7650 West Highway 29 Georgetown TX 78628, will conduct a public auction to satisfy a landlord's lien. Units will be sold to the highest bidder online. A \$100 cash clean up deposit is required. Seller reserves the right to withdraw any unit or not accept any bid at time of sale. Sale will be held online at www.LockerFox.com starting on or after September 1, 2022, and bidding will close on or after September 8, 2022 at 10am. General description of contents: general household items/personal goods. Names of tenants as they appear on the lease: Jobby Baza. Tenants may redeem their goods for full payment in cash or money order only up to time of auction. Call RightSpace Storage at 512-639-8835.

RIGHTSPACE STORAGE AUCTION NOTICE Lockerfox.com In accordance with the Texas property code, Chapter 59, RightSpace Storage 16450 N FM 620 Round Rock TX 78681, will conduct a public auction to satisfy a landlord's lien. Units will be sold to the highest bidder online. A \$100 cash clean up deposit is required. Seller reserves the right to withdraw any unit or not accept any bid at time of sale. Sale will be held online at www.LockerFox.com starting on or after September 1, 2022 and bidding will close on or after September 8, 2022 at 10am. General description of contents: household items/personal goods. Names of tenants as they appear on the lease are: Jessica Williamson. Tenants may redeem their goods for full payment in cash or money order only up to time of auction. Call RightSpace Storage at 512-248-1518.

pending in the Probate Court Number of Travis County, Texas, to Konstantina Petropoulos as Independent Executor. All persons having claims against said estate are hereby required to present the claims to the undersigned within the time and in the manner prescribed by law. /s/ Michele A. Mobley DuBois, Bryant & Campbell, LLP 303 Colorado Street, Suite 2300 Austin, Texas 78701 Dated: August 18, 2022

NOTICE TO CREDITORS Notice is hereby given that original Letters Testamentary for the Estate of Janice M. Metcalf A/K/A Janice Marie Metcalf, Deceased, were issued on August 18, 2022, in Cause No. C-1-PB-22-001547, pending in the Probate Court Number One, Travis County, Texas, In Matters Probate to: Daniel P. Hansen. All persons having claims against this Estate which is currently being administered are required to present them to the undersigned within the time and in the manner prescribed by law. Daniel P. Hansen, c/o William R. Leighton, 248 Addie Roy Road, Suite B-204, Austin, Texas 78746. DATED

the 18 of August 2022, William R. Leighton, Attorney for Daniel P. Hansen, State Bar No. 12185320, Leighton, Michaux, Adkinson & Brown, PLLC. 248 Addie Roy Road, Suite B-204, Austin, Texas 78746, Telephone 512-322-2001, Fax 512-322-0882

NOTICE TO CREDITORS Notice is hereby given that original Letters Testamentary for the estate of Joyce E. Greer, a/k/a Joyce Fay Greer, Deceased, Cause No. 22-0565-CP4, pending in the Probate Court of Williamson County, Texas, were issued on August 16, 2022 to Amy Donovan. — All persons having claims against this Estate are required to present them to the undersigned within the time and in the manner prescribed by law. - c/o: Caitlin Haney Johnston - The Haney Law Firm, 808 W. 10th Street, Suite 100, Austin, Texas, 78701, Telephone: (512) 476-2212, Fax: (512) 476-2202. DATED the 18th day of August, 2022. - Caitlin Haney Johnston, State Bar No. 24087661, Attorney for Amy Donovan.

NOTICE TO CREDITORS Notice is hereby given that original Letters Testamentary for the Estate of Teri Lynne Manry,

Deceased, were issued on June 14, 2022 under Docket No. C-1-PB-21-002835, pending in the Probate Court of Travis County, Texas, to Christina Manry. Claims may be presented in care of the attorney for the estate, addressed as follows: Christina Manry, Independent Executor, Estate of Teri Lynne Manry, Deceased c/o Law Office of Richard Cahan, 209 12th Street, Suite 109, Pflugerville, Texas 78660. All persons having claims against this estate, which is currently being administered, are required to present them within the time and in the manner prescribed by law. DATED August 17, 2022 By: /s/ Richard Cahan - Attorney for Christina Manry Independent Executor

NOTICE TO CREDITORS Notice is hereby given that original Letters Testamentary for the Estate of Thomas B. Weekley, Deceased, were issued on August 11, 2022, in Docket No. C-1-PB-22-001372, pending in the Probate Court Number One of Travis County, Texas, to: Carolyn N. Weekley and Leslie Annette White The residence of the Independent Co-Executor Carolyn N.

Weekley is in Austin, Texas and the residence of the Independent Co-Executor Leslie Annette White is in Bartlesville, Oklahoma. The post office address is as follows: c/o AKINS, NOWLIN & PREWITT, L.L.P. 896 Summit Street, Suite 106 P. O. Box 249 Round Rock, Texas 78680-0249 All persons having claims against the Estate which is currently being administered are required to present them within the time and in the manner prescribed by law. DATED the 19 th day of August, 2022. AKINS, NOWLIN & PREWITT, L.L.P. 896 Summit Street, Suite 106 P. O. Box 249 Round Rock, Texas 78680 (512) 244-0001 FAX: (512) 244-9733 By: /s/ Rick Akins Rick Akins State Bar No. 00962200 ATTORNEYS FOR ESTATE

NOTICE TO CREDITORS Notice is hereby given that original Letters Testamentary for the Estate of Wilbert Lee Pickens, Jr., Deceased, were issued on August 11, 2022, in Cause No. C-1-PB-22-000493

www.LockerFox.com In accordance with the Texas property code, Chapter 59, RightSpace Storage, 8956 Research Blvd., Austin, TX 78758, will conduct a public auction to satisfy a landlord's lien. Units will be sold to the highest bidder online. A \$100 cash clean up deposit is required. Seller reserves the right to withdraw any unit or not accept any bid at time of sale. Sale will be held online at www.LockerFox.com starting on or after Sept. 1st 2022 and bidding will close on or after Sept. 8th 2022 at 10am. General description of contents: household items/personal goods. Names of tenants as they appear on the lease are: Dennis Vaughn, Maria Perez - Tamayo, Maribel Perez. Tenants may redeem their goods for full payment in cash or money order only up to time of auction. Call RightSpace Storage at 512-380-9111.

RIGHTSPACE STORAGE AUCTION NOTICE Lockerfox.com

In accordance with the Texas property code, Chapter 59, RightSpace Storage 7650 West Highway 29 Georgetown TX 78628, will conduct a public auction to satisfy a landlord's lien. Units will be sold to the highest bidder online. A \$100 cash clean up deposit is required. Seller reserves the right to withdraw any unit or not accept any bid at time of sale. Sale will be held online at www.LockerFox.com starting on or after September 1, 2022, and bidding will close on or after September 8, 2022 at 10am. General description of contents: general household items/personal goods. Names of tenants as they appear on the lease: Jobby Baza. Tenants may redeem their goods for full payment in cash or money order only up to time of auction. Call RightSpace Storage at 512-639-8835.

RIGHTSPACE STORAGE AUCTION NOTICE Lockerfox.com

In accordance with the Texas property code, Chapter 59, RightSpace Storage 16450 N FM 620 Round Rock TX 78681, will conduct a public auction to satisfy a landlord's lien. Units will be sold to the highest bidder online. A \$100 cash clean up deposit is required. Seller reserves the right to withdraw any unit or not accept any bid at time of sale. Sale will be held online at www.LockerFox.com starting on or after September 1, 2022 and bidding will close on or after September 8, 2022 at 10am. General description of contents: household items/personal goods. Names of tenants as they appear on the lease are: Jessica Williamson. Tenants may redeem their goods for full payment in cash or money order only up to time of auction. Call RightSpace Storage at 512-248-1518.

RIGHTSPACE STORAGE AUCTION NOTICE Lockerfox.com

In accordance with the Texas property code, Chapter 59, RightSpace Storage 16450 N FM 620 Round Rock TX 78681, will conduct a public auction to satisfy a landlord's lien. Units will be sold to the highest bidder online. A \$100 cash clean up deposit is required. Seller reserves the right to withdraw any unit or not accept any bid at time of sale. Sale will be held online at www.LockerFox.com starting on or after September 1, 2022 and bidding will close on or after September 8, 2022 at 10am. General description of contents: household items/personal goods. Names of tenants as they appear on the lease are: Jessica Williamson. Tenants may redeem their goods for full payment in cash or money order only up to time of auction. Call RightSpace Storage at 512-248-1518.

AC CLASSIFIEDS

Looking for something more?
Check out austinchronicle.com/classifieds for even more great ads online.

PUBLIC STORAGE NOTICE Lockerfox.com In accordance with the Texas

STICKERS, LABELS, DECALS

We print stuff that sticks!
512-873-9626 TheBumperSticker.com

HARMONICA LESSONS

michaelrubinharmonica.com 512-619-0761

HUGHESNET SATELLITE INTERNET

Finally, no hard data limits! Call Today for speeds up to 25mbps as low as \$59.99/mo! \$75 gift card, terms apply. 1-866-544-5758 (AAN CAN)

4G LTE HOME INTERNET NOW AVAILABLE!

Get GotW3 with lightning fast speeds plus take your service with you when you travel! As low as \$109.99/mo! 1-866-571-1325 (AAN CAN)

AUDIOPHILES WANTED

for one-day immersive music & art fest. Local visual artists + transcendent music = your perfect Saturday. Sept. 3. Tickets @ thelongcenter.org/events/lookout-fest

CREDIT CARD DEBT RELIEF!

Reduce payment by up to 50%! Get one LOW affordable payment/month. Reduce interest. Stop calls. FREE no-obligation consultation Call 1-855-761-1456 (AAN CAN)

TOP CASH PAID FOR OLD GUITARS!

1920-1980 Gibson, Martin, Fender, Gretsch, Epiphone, Guild, Mosrite, Rickenbacker, Prairie State, D'Angelico, Stromberg. And Gibson Mandolins / Banjos. 877-589-0747 (AAN CAN)

READY TO QUIT SMOKING?

HypnosisAustin.com 512-200-4249

ARE YOU BEHIND \$10K OR MORE ON YOUR TAXES?

Stop wage & bank levies, liens & audits, unfiled tax returns, payroll issues, & resolve tax debt FAST. Call 877-414-2089 (Hours: Mon-Fri 7am-5pm PST) (AAN CAN)

A RISK WORTH TAKING

From food trucks to visual art installations to music that transcends categorization, Long Center's lookOUT Fest is how Austin's most curious have a good time. If it's good enough for Soundfinder, it's good enough for you. You're looking at back page ads, so what do you really have to lose? Sept. 3. Tickets @ thelongcenter.org/events/lookout-fest

PAYING TOP CASH FOR MEN'S SPORT WATCHES!

Rolex, Breitling, Omega, Patek Philippe, Heuer, Daytona, GMT, Submariner and Speedmaster. Call 888-320-1052 (AAN CAN)

ATTENTION VIAGRA USERS:

Generic 100 mg blue pills or generic 20 mg yellow pills. Get 45 plus 5 free \$99 + S/H. Call Today 1-877-707-5517 (AAN CAN)

SEMEN DONORS NEEDED

\$100 per specimen. Healthy college educated males, 18-39 years old. For an application visit beasperm donor.com

CASH FOR CARS!

We buy all cars! Junk, high-end, totaled – it doesn't matter! Get free towing and same day cash! NEWER MODELS too! Call 866-535-9689 (AAN CAN)

DIRECTV SATELLITE TV SERVICE STARTING AT \$74.99/MONTH!

Free Installation! 160+ channels available. Call Now to Get the Most Sports & Entertainment on TV! 877-310-2472 (AAN CAN)

THIRD COAST COFFEE

LOCAL * ORGANIC * FAIR TRADE
Wholesale & Retail Available
Order online * Pick up Mon-Fri 9am-6pm
www.thirdcoastcoffee.com

BATH & SHOWER UPDATES

in as little as ONE DAY! Affordable prices - No payments for 18 months! Lifetime warranty & professional installs. Senior & Military Discounts available. Call 1-866-370-2939 (AAN CAN)



**DEANDRA
GRANT LAW**
TEXAS TRIAL ATTORNEYS



Criminal & Federal Defense



DWI Defense



Personal Injury



Proudly Serving Hays & Travis County

The Defense is Ready. Contact us Today.

AustinDWISite.com • (512) 279-6600



**GET THE AUSTIN CHRONICLE
DELIVERED STRAIGHT TO
YOUR DOOR.**

LEARN MORE AT [AUSTINCHRONICLE.COM/
SUBSCRIPTIONS](http://AUSTINCHRONICLE.COM/SUBSCRIPTIONS)

My ATX Water

Austin's Smart Water Meter System

Don't have your new meter yet? Don't worry!

You can still join the **My ATX Water Customer Portal** now to access monthly water use data and other benefits at myatxwater.org.

BENEFITS OF MY ATX WATER

- Continuous usage and leak notifications
- Personalized alerts
- Water budgeting features
- Customized water-saving tips and rebate information



ONE
SMART
METER
SYSTEM



Austin
WATER
austinwater.org